

Miyano

**BNJ 51 SY2/SY5**



# High-tech from heimatec - heimatec - Tools and systems for productive turning and milling

heimatec belongs to the international technology and quality leaders for precision tools and specializes in the development and production of high-precision static and live tools for all CNC lathes, CNC turn-/mill machines and CNC machining centers.

The range of products\* spans from static BMT and VDI tool holders, live tools up to highly complex customer-specific individual solutions. heimatec, headquartered in Renchen, has a own subsidiary in Asia and India and numerous representatives as well as trading partners all over the world.

## \*OUR PRODCUTS

Static tool holders

Live tool units

Precision tools

Tools for turning and machining centres

Tools for swiss type lathes

Tool changing and uick-change systems

Tool systems for gear production

Digital tool management

This catalogue, including all its parts, is protected by copyright. Any use outside the restricted limitations of the Copyright Act without the consent of heimatec is inadmissible and liable to prosecution. This applies in particular to duplication, translation, microfilming and storage and processing in electronic systems.

**heimatec GmbH** reserves the right to make technical changes at any time without giving prior notice. This applies in particular to adjustments at any time to meet new or changed international standards, or in case of further developments of our products or manufacturing processes.

The current version of our General Terms and Conditions can be found on our website.

Part-#	Name
--------	------

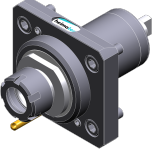
	<b>8 010 45 047</b>	<b>Axial drilling and milling head ER 25 M</b>	1.740
		Weight [kg]:	1.740
		Tool drive:	Flat (~DIN 1809)
		Shank size [mm]:	45.00
		Tool adaption:	ER 25 M
		Gear ratio [i]:	1:1
		Torque max [Nm]:	50
		Rotation max [1/min]:	6000
		Rotating direction:	same
		Coolant:	EXT

	<b>8 010 45 050</b>	<b>Axial drilling and milling head ER 25 M IC</b>	2.000
		Weight [kg]:	2.000
		Tool drive:	Flat (~DIN 1809)
		Shank size [mm]:	45.00
		Shank type:	BMT
		Tool adaption:	ER 25
		Gear ratio [i]:	1:1
		Torque max [Nm]:	50
		Rotation max [1/min]:	6000
		Rotating direction:	same
	Coolant:	IC/Ext	
	Pressure max [bar]:	25	

	<b>8 010 45 061</b>	<b>Axial drilling and milling head ER 25</b>	1.780
		Weight [kg]:	1.780
		Tool drive:	Flat (~DIN 1809)
		Shank size [mm]:	45.00
		Shank type:	BMT
		Tool adaption:	ER 25
		Gear ratio [i]:	1:1
		Torque max [Nm]:	50
		Rotation max [1/min]:	6000
		Rotating direction:	same
	Coolant:	EXT	

	<b>8 010 45 096</b>	<b>Axial drilling and milling head ER 25 AX UT IC</b>	2.000
		Weight [kg]:	2.000
		Tool drive:	Flat (~DIN 1809)
		Shank size [mm]:	45.00
		Shank type:	BMT
		Tool adaption:	ER 25 A - u-tec
		Gear ratio [i]:	1:1
		Torque max [Nm]:	50
		Rotation max [1/min]:	6000
		Rotating direction:	same
	Coolant:	IC/Ext	
	Pressure max [bar]:	25	
	Please note:	Combi bearing	

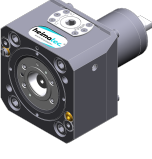
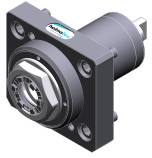
Part-#	Name	
<b>8 010 45 103</b>	<b>Axial milling and drill holder ER 25 AX UT</b>	
	Weight [kg]:	1.870
	Tool drive:	Flat (~DIN 1809)
	Shank size [mm]:	45.00
	Shank type:	BMT
	Tool adaption:	ER 25 A - u-tec
	Gear ratio [i]:	1:1
	Torque max [Nm]:	50
	Rotation max [1/min]:	6000
	Rotating direction:	same
	Coolant:	EXT
	Please note:	Combi bearing
<b>8 010 45 181</b>	<b>Axial drilling and milling head C 3 IC</b>	
	Notation:	180° reversible
	Tool drive:	Flat (~DIN 1809)
	Shank size [mm]:	45.00
	Shank type:	BMT
	Tool adaption:	heimatec Capto(TM) C 3
	Gear ratio [i]:	1:1
	Torque max [Nm]:	25
	Rotation max [1/min]:	8000
	Rotating direction:	same
	Coolant:	IC/Ext
	Pressure max [bar]:	100
	Please note:	Check applicability; tool length check !
<b>8 010 45 183</b>	<b>Axial drilling and milling head C 3</b>	
	Weight [kg]:	3.800
	Notation:	180° reversible
	Tool drive:	Flat (~DIN 1809)
	Shank size [mm]:	45.00
	Shank type:	BMT
	Tool adaption:	heimatec Capto(TM) C 3
	Gear ratio [i]:	1:1
	Torque max [Nm]:	32
	Rotation max [1/min]:	8000
	Rotating direction:	same
	Coolant:	EXT
	Please note:	Check applicability; tool length check !
<b>8 010 45 224</b>	<b>Axial drilling and milling head ER 25 AX UT</b>	
	Weight [kg]:	1.900
	Tool drive:	Flat (~DIN 1809)
	Shank size [mm]:	45.00
	Shank type:	BMT
	Tool adaption:	ER 25 A - u-tec
	Gear ratio [i]:	1:1
	Torque max [Nm]:	50
	Rotation max [1/min]:	15000
	Rotating direction:	same
	Coolant:	EXT

Part-#	Name	
	<b>8 010 45 225</b>	<b>Axial drilling and milling head ER 25 AX UT IC</b>
	Weight [kg]:	2.100
	Tool drive:	Flat (~DIN 1809)
	Shank size [mm]:	45.00
	Shank type:	BMT
	Tool adaption:	ER 25 A - u-tec
	Gear ratio [i]:	1:1
	Torque max [Nm]:	50
	Rotation max [1/min]:	12000
	Rotating direction:	same
	Coolant:	IC/Ext
	Pressure max [bar]:	100
	Please note:	Dryrun possible
		<b>8 010 46 092</b>
Weight [kg]:		1.700
Tool drive:		Flat (~DIN 1809)
Shank size [mm]:		45.00
Shank type:		BMT
Tool adaption:		HT 4
Gear ratio [i]:		1:1
Torque max [Nm]:		50
Rotation max [1/min]:		6000
Rotating direction:		same
Coolant:	EXT	
	<b>8 010 46 112</b>	<b>Axial drilling and milling head HT 4 IC</b>
	Weight [kg]:	1.980
	Tool drive:	Flat (~DIN 1809)
	Shank size [mm]:	45.00
	Shank type:	BMT
	Tool adaption:	HT 4
	Gear ratio [i]:	1:1
	Torque max [Nm]:	50
	Rotation max [1/min]:	6000
	Rotating direction:	same
Coolant:	IC/Ext	
Pressure max [bar]:	25	
	<b>8 010 46 206</b>	<b>Axial drilling and milling head ER 32 AX UT</b>
	Weight [kg]:	2.110
	Version:	Special
	Tool drive:	Flat (~DIN 1809)
	Shank size [mm]:	45.00
	Shank type:	BMT
	Tool adaption:	ER 32 A - u-tec
	Gear ratio [i]:	1:1
	Torque max [Nm]:	50
	Rotation max [1/min]:	6000
	Rotating direction:	same
Coolant:	EXT	
Please note:	stronger bearing	

Part-#	Name	
<b>8 011 44 010</b>	<b>Axial milling head universal arbor 16</b>	
		<p>Weight [kg]: 1.820            Tool drive: Flat (~DIN 1809)            Shank size [mm]: 45.00            Shank type: BMT            Tool adaption: Universal arbor 16            Gear ratio [i]: 1:1            Torque max [Nm]: 50            Rotation max [1/min]: 6000            Rotating direction: same            Coolant: EXT            Please note: Taper roller bearings</p>
<b>8 011 44 021</b>	<b>Axial milling head universal arbor 3/4"</b>	
		<p>Weight [kg]: 1.840            Tool drive: Flat (~DIN 1809)            Shank size [mm]: 45.00            Shank type: BMT            Tool adaption: Universal arbor 3/4" (19,05mm)            Gear ratio [i]: 1:1            Torque max [Nm]: 50            Rotation max [1/min]: 6000            Rotating direction: same            Coolant: EXT            Please note: Taper roller bearings</p>
<b>8 011 45 018</b>	<b>Axial milling head universal arbor 22</b>	
		<p>Weight [kg]: 1.940            Tool drive: Flat (~DIN 1809)            Shank size [mm]: 45.00            Shank type: BMT            Tool adaption: Universal arbor 22            Gear ratio [i]: 1:1            Torque max [Nm]: 50            Rotation max [1/min]: 6000            Rotating direction: same            Coolant: EXT            Please note: Taper roller bearings</p>
<b>8 013 44 022</b>	<b>Axial drilling and milling head ER 16 AX UT</b>	
	<p>Weight [kg]: 2.350            Tool drive: Flat (~DIN 1809)            Shank size [mm]: 45.00            Shank type: BMT            Tool adaption: ER 16 A - u-tec            Gear ratio [i]: 1:4            Torque max [Nm]: 5            Rotation max [1/min]: 24000            Rotating direction: same            Coolant: EXT</p>	

Part-#	Name	
<b>8 013 44 023</b>	<b>Axial drilling and milling head ER 16 AX UT IC</b>	
	Weight [kg]:	2.450
	Tool drive:	Flat (~DIN 1809)
	Shank size [mm]:	45.00
	Shank type:	BMT
	Tool adaption:	ER 16 A - u-tec
	Gear ratio [i]:	1:4
	Torque max [Nm]:	5
	Rotation max [1/min]:	24000
	Rotating direction:	same
	Coolant:	IC/Ext
	Pressure max [bar]:	100
	Please note:	Dryrun possible
<b>8 019 44 012</b>	<b>Axial drilling and milling head ER 20</b>	
	Weight [kg]:	4.020
	Notation:	offset
	Tool drive:	Flat (~DIN 1809)
	Shank size [mm]:	45.00
	Shank type:	BMT
	Tool adaption:	ER 20
	Gear ratio [i]:	1:2
	Torque max [Nm]:	12
	Rotation max [1/min]:	12000
	Rotating direction:	opposite
	Coolant:	EXT
<b>8 019 44 019</b>	<b>Axial drilling and milling head ER 16 AX UT</b>	
	Weight [kg]:	4.260
	Notation:	offset
	Tool drive:	Flat (~DIN 1809)
	Shank size [mm]:	45.00
	Shank type:	BMT
	Tool adaption:	ER 16 A - u-tec
	Gear ratio [i]:	1:2
	Torque max [Nm]:	12
	Rotation max [1/min]:	10000
	Rotating direction:	opposite
	Coolant:	EXT
	Please note:	stronger bearing
<b>8 019 44 020</b>	<b>Axial drilling and milling head ER 16 M</b>	
	Weight [kg]:	3.960
	Notation:	offset
	Tool drive:	Flat (~DIN 1809)
	Shank size [mm]:	45.00
	Shank type:	BMT
	Tool adaption:	ER 16
	Gear ratio [i]:	1:3
	Torque max [Nm]:	10
	Rotation max [1/min]:	15000
	Rotating direction:	opposite
	Coolant:	EXT
	Offset [mm]:	34,5

Part-#	Name	
<b>8 019 44 060</b>	<b>Axial drilling and milling head ER 20</b>	
	Weight [kg]:	4.000
	Notation:	offset
	Tool drive:	Flat (~DIN 1809)
	Shank size [mm]:	45.00
	Shank type:	BMT
	Tool adaption:	ER 20
	Gear ratio [i]:	1:3
	Torque max [Nm]:	10
	Rotation max [1/min]:	15000
	Rotating direction:	opposite
	Coolant:	EXT
	Offset [mm]:	34,5
<b>8 019 44 073</b>	<b>Axial drilling and milling head ER 20 AX UT IC</b>	
	Weight [kg]:	4.910
	Notation:	offset; 180° reversible
	Tool drive:	Flat (~DIN 1809)
	Shank size [mm]:	45.00
	Shank type:	BMT
	Tool adaption:	ER 20 A - u-tec
	Gear ratio [i]:	1:2
	Torque max [Nm]:	16
	Rotation max [1/min]:	12000
	Rotating direction:	opposite
	Coolant:	IC/Ext
	Pressure max [bar]:	140
	Please note:	stronger bearing
	Offset [mm]:	34,5
<b>8 019 44 078</b>	<b>Axial drilling and milling head ER 16 AX UT</b>	
	Weight [kg]:	3.890
	Notation:	offset
	Tool drive:	Flat (~DIN 1809)
	Shank size [mm]:	45.00
	Shank type:	BMT
	Tool adaption:	ER 16 A - u-tec
	Gear ratio [i]:	1:3
	Torque max [Nm]:	10
	Rotation max [1/min]:	15000
	Rotating direction:	opposite
	Coolant:	EXT
	Offset [mm]:	34,5
<b>8 019 44 114</b>	<b>Axial drilling and milling head ER 20 AX UT</b>	
	Notation:	offset; 180° reversible
	Tool drive:	Flat (~DIN 1809)
	Shank size [mm]:	45.00
	Shank type:	BMT
	Tool adaption:	ER 20 A - u-tec
	Gear ratio [i]:	1:2
	Torque max [Nm]:	16
	Rotation max [1/min]:	12000
	Rotating direction:	opposite
	Coolant:	EXT
	Please note:	stronger bearing
	Offset [mm]:	34,5

Part-#	Name	
<b>8 019 45 093</b>	<b>Axial drilling and milling head ER 25 AX UT IC</b>	
	Weight [kg]:	5.860
	Notation:	offset; 180° reversible
	Tool drive:	Flat (~DIN 1809)
	Shank size [mm]:	45.00
	Shank type:	BMT
	Tool adaption:	ER 25 A - u-tec
	Gear ratio [i]:	2:1
	Torque max [Nm]:	50
	Rotation max [1/min]:	3000
	Rotating direction:	same
	Coolant:	IC/Ext
	Pressure max [bar]:	140
	Please note:	stronger bearing
	Offset [mm]:	69
<b>8 019 45 102</b>	<b>Axial drilling and milling head ER 25 AX UT</b>	
	Weight [kg]:	5.400
	Notation:	offset; 180° reversible
	Tool drive:	Flat (~DIN 1809)
	Shank size [mm]:	45.00
	Shank type:	BMT
	Tool adaption:	ER 25 A - u-tec
	Gear ratio [i]:	2:1
	Torque max [Nm]:	50
	Rotation max [1/min]:	3000
	Rotating direction:	same
	Coolant:	EXT
	Please note:	stronger bearing
	Offset [mm]:	69
<b>8 030 44 082</b>	<b>Radial drilling and milling head ER 16 AX UT</b>	
	Notation:	180° reversible
	Tool drive:	Flat (~DIN 1809)
	Shank size [mm]:	45.00
	Shank type:	BMT
	Tool adaption:	ER 16 A - u-tec
	Gear ratio [i]:	1:4
	Torque max [Nm]:	5
	Rotation max [1/min]:	24000
	Rotating direction:	opposite
	Coolant:	EXT
	Center distance [mm]:	65
<b>8 030 44 099</b>	<b>Radial drilling and milling head ER 16 AX UT IC</b>	
	Weight [kg]:	4.900
	Notation:	180° reversible
	Tool drive:	Flat (~DIN 1809)
	Shank size [mm]:	45.00
	Shank type:	BMT
	Tool adaption:	ER 16 A - u-tec
	Gear ratio [i]:	1:4
	Torque max [Nm]:	5
	Rotation max [1/min]:	24000
	Rotating direction:	opposite
	Coolant:	IC/Ext
	Pressure max [bar]:	140
	Center distance [mm]:	65

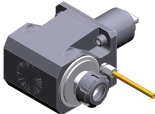
Part-#	Name	
<b>8 030 44 109</b>	<b>Radial drilling and milling head ER 20 AX UT IC</b>	
	Weight [kg]:	5.950
	Notation:	180° reversible
	Tool drive:	Flat (~DIN 1809)
	Shank size [mm]:	45.00
	Shank type:	BMT
	Tool adaption:	ER 20 A - u-tec
	Gear ratio [i]:	1:2
	Torque max [Nm]:	16
	Rotation max [1/min]:	12000
	Rotating direction:	same
	Coolant:	IC/Ext
	Pressure max [bar]:	140
	Please note:	stronger bearing
	Center distance [mm]:	77
<b>8 030 45 096</b>	<b>Radial drilling and milling head ER 25</b>	
	Weight [kg]:	5.190
	Notation:	180° reversible
	Tool drive:	Flat (~DIN 1809)
	Shank size [mm]:	45.00
	Shank type:	BMT
	Tool adaption:	ER 25
	Gear ratio [i]:	1:2
	Torque max [Nm]:	12
	Rotation max [1/min]:	12000
	Rotating direction:	opposite
	Coolant:	EXT
	Center distance [mm]:	65
<b>8 030 45 101</b>	<b>Radial drilling and milling head ER 25 IC</b>	
	Weight [kg]:	5.450
	Notation:	180° reversible
	Tool drive:	Flat (~DIN 1809)
	Shank size [mm]:	45.00
	Shank type:	BMT
	Tool adaption:	ER 25
	Gear ratio [i]:	1:2
	Torque max [Nm]:	12
	Rotation max [1/min]:	12000
	Rotating direction:	opposite
	Coolant:	IC/Ext
	Pressure max [bar]:	140
	Center distance [mm]:	65
<b>8 030 45 120</b>	<b>Radial drilling and milling head ER 25</b>	
	Weight [kg]:	5.400
	Notation:	180° reversible
	Tool drive:	Flat (~DIN 1809)
	Shank size [mm]:	45.00
	Shank type:	BMT
	Tool adaption:	ER 25
	Gear ratio [i]:	1:1
	Torque max [Nm]:	50
	Rotation max [1/min]:	12000
	Rotating direction:	opposite
	Coolant:	EXT
	Center distance [mm]:	65

Part-#	Name
--------	------

<b>8 030 45 121</b>	<b>Radial drilling and milling head ER 25 IC</b>
Weight [kg]:	5.570
Notation:	180° reversible
Tool drive:	Flat (~DIN 1809)
Shank size [mm]:	45.00
Shank type:	BMT
Tool adaption:	ER 25
Gear ratio [i]:	1:1
Torque max [Nm]:	50
Rotation max [1/min]:	12000
Rotating direction:	opposite
Coolant:	IC/Ext
Pressure max [bar]:	140
Please note:	strong version
Center distance [mm]:	65

<b>8 030 45 136</b>	<b>Radial drilling and milling head ER 25 AX UT IC</b>
Weight [kg]:	5.370
Notation:	180° reversible
Tool drive:	Flat (~DIN 1809)
Shank size [mm]:	45.00
Shank type:	BMT
Tool adaption:	ER 25 A - u-tec
Gear ratio [i]:	1:1
Torque max [Nm]:	50
Rotation max [1/min]:	12000
Rotating direction:	opposite
Coolant:	IC/Ext
Pressure max [bar]:	140
Center distance [mm]:	65



<b>8 030 45 163</b>	<b>Angle-mill- and drill holder ER 25 AX UT</b>
Weight [kg]:	5.700
Notation:	180° reversible
Tool drive:	Flat (~DIN 1809)
Shank size [mm]:	45.00
Tool adaption:	ER 25 A - u-tec
Gear ratio [i]:	1:1
Torque max [Nm]:	50
Rotation max [1/min]:	6000
Rotating direction:	opposite
Coolant:	EXT
Please note:	Combi bearing
Center distance [mm]:	65



<b>8 030 45 167</b>	<b>Radial drilling and milling head ER 25 AX UT</b>
Weight [kg]:	5.790
Notation:	180° reversible
Tool drive:	Flat (~DIN 1809)
Shank size [mm]:	45.00
Shank type:	BMT
Tool adaption:	ER 25 A - u-tec
Gear ratio [i]:	1:3
Torque max [Nm]:	12
Rotation max [1/min]:	18000
Rotating direction:	same
Coolant:	EXT

Part-#	Name
--------	------

Please note: stronger bearing  
Center distance [mm]: 77

**8 030 45 169**

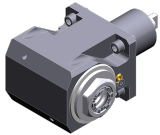

**Radial drilling and milling head ER 25 AX UT**  
Weight [kg]: 5.340  
Notation: 180° reversible  
Tool drive: Flat (~DIN 1809)  
Shank size [mm]: 45.00  
Shank type: BMT  
Tool adaption: ER 25 A - u-tec  
Gear ratio [i]: 1:1  
Torque max [Nm]: 50  
Rotation max [1/min]: 12000  
Rotating direction: opposite  
Coolant: EXT  
Center distance [mm]: 65

**8 030 45 198**



**Angle-mill- and drill holder ER 25 AX UT IC**  
Weight [kg]: 5.800  
Notation: 180° reversible  
Tool drive: Flat (~DIN 1809)  
Shank size [mm]: 45.00  
Shank type: BMT  
Tool adaption: ER 25 A - u-tec  
Gear ratio [i]: 1:1  
Torque max [Nm]: 50  
Rotation max [1/min]: 6000  
Rotating direction: opposite  
Coolant: IC/Ext  
Pressure max [bar]: 140  
Please note: Combi bearing  
Center distance [mm]: 65

**8 030 45 211**

**Radial drilling and milling head ER 25 AX UT**  
Weight [kg]: 5.770  
Notation: 180° reversible  
Tool drive: Flat (~DIN 1809)  
Shank size [mm]: 45.00  
Shank type: BMT  
Tool adaption: ER 25 A - u-tec  
Gear ratio [i]: 1:2  
Torque max [Nm]: 16  
Rotation max [1/min]: 12000  
Rotating direction: same  
Coolant: EXT  
Please note: stronger bearing  
Center distance [mm]: 77

**8 030 45 239**

**Radial drilling and milling head ER 25 AX UT IC**  
Weight [kg]: 5.990  
Notation: 180° reversible  
Tool drive: Flat (~DIN 1809)  
Shank size [mm]: 45.00  
Shank type: BMT  
Tool adaption: ER 25 A - u-tec  
Gear ratio [i]: 1:3  
Torque max [Nm]: 12

**Part-#                      Name**

Rotation max [1/min]: 18000  
 Rotating direction: same  
 Coolant: IC/Ext  
 Pressure max [bar]: 140  
 Please note: stronger bearing  
 Center distance [mm]: 77

**8 030 45 253              Radial drilling and milling head ER 25 AX UT**

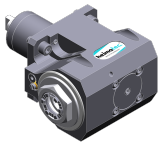

Weight [kg]: 5.480  
 Notation: 180° reversible  
 Tool drive: Flat (~DIN 1809)  
 Shank size [mm]: 45.00  
 Shank type: BMT  
 Tool adaption: ER 25 A - u-tec  
 Gear ratio [i]: 2:1  
 Torque max [Nm]: 63  
 Rotation max [1/min]: 3000  
 Rotating direction: opposite  
 Coolant: EXT  
 Please note: Combi bearing  
 Center distance [mm]: 65

**8 030 45 346              Radial drilling and milling head C 3 IC**





Notation: 180° reversible  
 Tool drive: Flat (~DIN 1809)  
 Shank size [mm]: 45.00  
 Shank type: BMT  
 Tool adaption: heimatec Capto(TM) C 3  
 Gear ratio [i]: 1:1  
 Torque max [Nm]: 25  
 Rotation max [1/min]: 8000  
 Rotating direction: opposite  
 Coolant: IC/Ext  
 Pressure max [bar]: 140  
 Please note: Check applicability; note tool length!  
 Center distance [mm]: 65

**8 030 45 351              Radial drilling and milling head C 3**

Notation: 180° reversible  
 Tool drive: Flat (~DIN 1809)  
 Shank size [mm]: 45.00  
 Shank type: BMT  
 Tool adaption: heimatec Capto(TM) C 3  
 Gear ratio [i]: 1:1  
 Torque max [Nm]: 25  
 Rotation max [1/min]: 8000  
 Rotating direction: opposite  
 Coolant: EXT  
 Please note: Check applicability; note tool length!  
 Center distance [mm]: 65



Part-#	Name	
<b>8 030 45 563</b>	<b>Radial drilling and milling head Weldon 16</b>	
	Weight [kg]:	5.850
	Notation:	180° reversible
	Tool drive:	Flat (~DIN 1809)
	Shank size [mm]:	45.00
	Shank type:	BMT
	Tool adaption:	Weldon (DIN 1835 b) 16
	Gear ratio [i]:	1:1
	Torque max [Nm]:	50
	Rotation max [1/min]:	6000
	Rotating direction:	opposite
	Coolant:	EXT
	Please note:	Combi bearing
	Center distance [mm]:	65
<b>8 030 45 599</b>	<b>Radial drilling and milling head ER 25 AX UT IC</b>	
	Weight [kg]:	5.980
	Notation:	180° reversible
	Tool drive:	Flat (~DIN 1809)
	Shank size [mm]:	45.00
	Shank type:	BMT
	Tool adaption:	ER 25 A - u-tec
	Gear ratio [i]:	1:2
	Torque max [Nm]:	16
	Rotation max [1/min]:	12000
	Rotating direction:	same
	Coolant:	IC/Ext
	Pressure max [bar]:	140
	Please note:	stronger bearing
	Center distance [mm]:	77
<b>8 030 46 196</b>	<b>Radial drilling and milling head HT 4</b>	
	Notation:	180° reversible
	Tool drive:	Flat (~DIN 1809)
	Shank size [mm]:	45.00
	Shank type:	BMT
	Tool adaption:	HT 4
	Gear ratio [i]:	1:1
	Torque max [Nm]:	50
	Rotation max [1/min]:	6000
	Rotating direction:	opposite
	Coolant:	EXT
	Please note:	strong version
	Center distance [mm]:	65
<b>8 030 46 197</b>	<b>Radial drilling and milling head HT 4 IC</b>	
	Weight [kg]:	5.640
	Notation:	180° reversible
	Tool drive:	Flat (~DIN 1809)
	Shank size [mm]:	45.00
	Shank type:	BMT
	Tool adaption:	HT 4
	Gear ratio [i]:	1:1
	Torque max [Nm]:	50
	Rotation max [1/min]:	12000
	Rotating direction:	opposite
	Coolant:	IC/Ext
	Pressure max [bar]:	140

Part-#	Name	
	Center distance [mm]:	65
<b>8 030 46 356</b>	<b>Angle-mill- and drill holder ER 32 AX UT IC</b>	
	Notation:	180° reversible
	Tool drive:	Flat (~DIN 1809)
	Shank size [mm]:	45.00
	Shank type:	BMT
	Tool adaption:	ER 32 A - u-tec
	Gear ratio [i]:	1:1
	Torque max [Nm]:	50
	Rotation max [1/min]:	6000
	Rotating direction:	opposite
	Coolant:	IC/Ext
	Pressure max [bar]:	140
	Please note:	Combi bearing
	Center distance [mm]:	65
<b>8 030 46 563</b>	<b>Radial drilling and milling head ER 32 AX UT IC</b>	
	Weight [kg]:	5.480
	Notation:	180° reversible
	Tool drive:	Flat (~DIN 1809)
	Shank size [mm]:	45.00
	Shank type:	BMT
	Tool adaption:	ER 32 A - u-tec
	Gear ratio [i]:	1:1
	Torque max [Nm]:	50
	Rotation max [1/min]:	12000
	Rotating direction:	opposite
	Coolant:	IC/Ext
	Pressure max [bar]:	140
	Center distance [mm]:	65
<b>8 030 46 564</b>	<b>Radial drilling and milling head ER 32 AX UT</b>	
	Weight [kg]:	5.120
	Notation:	180° reversible
	Tool drive:	Flat (~DIN 1809)
	Shank size [mm]:	45.00
	Shank type:	BMT
	Tool adaption:	ER 32 A - u-tec
	Gear ratio [i]:	1:1
	Torque max [Nm]:	50
	Rotation max [1/min]:	12000
	Rotating direction:	opposite
	Coolant:	EXT
	Center distance [mm]:	65
<b>8 030 47 122</b>	<b>Radial drilling and milling head Weldon 25 IC</b>	
	Weight [kg]:	6.580
	Notation:	180° reversible
	Tool drive:	Flat (~DIN 1809)
	Shank size [mm]:	45.00
	Shank type:	BMT
	Tool adaption:	Weldon (DIN 1835 b) 25
	Gear ratio [i]:	2:1
	Torque max [Nm]:	63
	Rotation max [1/min]:	3000
	Rotating direction:	opposite

Part-#	Name	
	Coolant:	IC/Ext
	Pressure max [bar]:	140
	Please note:	Combi bearing
	Center distance [mm]:	65
<b>8 031 45 026</b>	<b>Radial milling head universal arbor 22</b>	
	Notation:	180° reversible
	Tool drive:	Flat (~DIN 1809)
	Shank size [mm]:	45.00
	Shank type:	BMT
	Tool adaption:	Universal arbor 22
	Gear ratio [i]:	2:1
	Torque max [Nm]:	63
	Rotation max [1/min]:	3000
	Rotating direction:	opposite
	Coolant:	EXT
	Please note:	Combi bearing
	Center distance [mm]:	65
<b>8 031 45 054</b>	<b>Radial milling head universal arbor 1"</b>	
	Weight [kg]:	6.040
	Notation:	180° reversible
	Tool drive:	Flat (~DIN 1809)
	Shank size [mm]:	45.00
	Shank type:	BMT
	Tool adaption:	Universal arbor 1" (25,4mm)
	Gear ratio [i]:	2:1
	Torque max [Nm]:	63
	Rotation max [1/min]:	3000
	Rotating direction:	opposite
	Coolant:	EXT
	Please note:	Combi bearing
	Center distance [mm]:	65
<b>8 031 46 004</b>	<b>Radial milling head universal arbor 27</b>	
	Notation:	180° reversible
	Tool drive:	Flat (~DIN 1809)
	Shank size [mm]:	45.00
	Shank type:	BMT
	Tool adaption:	Universal arbor 27
	Gear ratio [i]:	1:1
	Torque max [Nm]:	50
	Rotation max [1/min]:	6000
	Rotating direction:	opposite
	Coolant:	EXT
	Please note:	Combi bearing
	Center distance [mm]:	65
<b>8 033 45 061</b>	<b>Radial drilling and milling head ER 25 AX UT</b>	
	Weight [kg]:	5.500
	Notation:	offset; 180° reversible
	Tool drive:	Flat (~DIN 1809)
	Shank size [mm]:	45.00
	Shank type:	BMT
	Tool adaption:	ER 25 A - u-tec
	Gear ratio [i]:	3:1
	Torque max [Nm]:	32

Part-#	Name	
	Rotation max [1/min]:	3000
	Rotating direction:	same
	Coolant:	EXT
	Please note:	Combi bearing; check applicability!
	Center distance [mm]:	65
<b>8 037 42 002</b>	<b>Radial disk mill head arbor 10</b>	
	Weight [kg]:	4.600
	Notation:	180° reversible
	Version:	± 30° turnable
	Tool drive:	Flat (~DIN 1809)
	Shank size [mm]:	45.00
	Shank type:	BMT
	Tool adaption:	Arbor 10
	Gear ratio [i]:	2:1
	Torque max [Nm]:	32
	Rotation max [1/min]:	4000
	Rotating direction:	opposite
	Coolant:	EXT
	Center distance [mm]:	78
<b>8 037 43 004</b>	<b>Radial disk mill head arbor 13</b>	
	Weight [kg]:	4.630
	Notation:	180° reversible
	Version:	± 30° turnable
	Tool drive:	Flat (~DIN 1809)
	Shank size [mm]:	45.00
	Shank type:	BMT
	Tool adaption:	Arbor 13
	Gear ratio [i]:	2:1
	Torque max [Nm]:	32
	Rotation max [1/min]:	4000
	Rotating direction:	opposite
	Coolant:	EXT
	Center distance [mm]:	78
<b>8 039 45 076</b>	<b>Radial drilling and milling head ER 25 AX UT</b>	
	Weight [kg]:	5.900
	Notation:	180° reversible
	Version:	double spindle
	Tool drive:	Flat (~DIN 1809)
	Shank size [mm]:	45.00
	Shank type:	BMT
	Tool adaption:	ER 25 A - u-tec
	Gear ratio [i]:	1:1
	Torque max [Nm]:	50
	Rotation max [1/min]:	12000
	Rotating direction:	same/opposite
	Coolant:	EXT
	Center distance [mm]:	65



Part-#	Name	
<b>8 039 45 106</b>	<b>Radial drilling and milling head ER 25 AX UT</b>	
	Weight [kg]:	6.250
	Notation:	180° reversible
	Employment for:	Main- and sub spindle
	Version:	double spindle
	Tool drive:	Flat (~DIN 1809)
	Shank size [mm]:	45.00
	Shank type:	BMT
	Tool adaption:	ER 25 A - u-tec
	Gear ratio [i]:	1:1
	Torque max [Nm]:	25/Sp.
	Rotation max [1/min]:	12000
	Rotating direction:	same
	Coolant:	EXT
	Center distance [mm]:	50/86
<b>8 039 46 031</b>	<b>Radial drilling and milling head HT 4</b>	
	Weight [kg]:	6.400
	Notation:	180° reversible
	Employment for:	Main- and sub spindle
	Version:	double spindle
	Tool drive:	Flat (~DIN 1809)
	Shank size [mm]:	45.00
	Tool adaption:	HT 4
	Gear ratio [i]:	1:1
	Torque max [Nm]:	50
	Rotation max [1/min]:	12000
	Rotating direction:	same/opposite
	Coolant:	EXT
	Center distance [mm]:	65
<b>8 040 44 019</b>	<b>Universal head ± 90° adjustable ER 16</b>	
	Weight [kg]:	2.460
	Tool drive:	Flat (~DIN 1809)
	Shank size [mm]:	45.00
	Shank type:	BMT
	Tool adaption:	ER 16
	Gear ratio [i]:	1:1
	Torque max [Nm]:	10
	Rotation max [1/min]:	6000
	Rotating direction:	same
	Coolant:	EXT
	Please note:	Note swivel range!
	Center distance [mm]:	55
<b>8 040 44 021</b>	<b>Universal head ± 90° adjustable ER 16</b>	
	Weight [kg]:	2.700
	Notation:	180° reversible
	Tool drive:	Flat (~DIN 1809)
	Shank size [mm]:	45.00
	Shank type:	BMT
	Tool adaption:	ER 16
	Gear ratio [i]:	1:1
	Torque max [Nm]:	10
	Rotation max [1/min]:	6000
	Rotating direction:	same
	Coolant:	EXT

Part-#	Name	
	Please note:	position can be pinned; note swivel range!
	Center distance [mm]:	55
<b>8 040 44 023</b>	<b>Universal head ± 90° adjustable ER 20</b>	
	Weight [kg]:	2.800
	Tool drive:	Flat (~DIN 1809)
	Shank size [mm]:	45.00
	Shank type:	BMT
	Tool adaption:	ER 20
	Gear ratio [i]:	1:1
	Torque max [Nm]:	10
	Rotation max [1/min]:	6000
	Rotating direction:	same
	Coolant:	EXT
	Please note:	Note swivel range!
	Center distance [mm]:	55
<b>8 040 44 104</b>	<b>Universal head ± 90° adjustable ER 16</b>	
	Notation:	180° reversible
	Version:	45° position can be pinned
	Tool drive:	Flat (~DIN 1809)
	Shank size [mm]:	45.00
	Shank type:	BMT
	Tool adaption:	ER 16
	Gear ratio [i]:	1:1
	Torque max [Nm]:	10
	Rotation max [1/min]:	6000
	Rotating direction:	same
	Coolant:	EXT
	Center distance [mm]:	55
<b>8 043 44 004</b>	<b>Universal head +105°/-20° adj. ER16AX UTIK</b>	
	Weight [kg]:	5.450
	Notation:	offset
	Tool drive:	Flat (~DIN 1809)
	Shank size [mm]:	45.00
	Shank type:	BMT
	Tool adaption:	ER 16 A - u-tec
	Gear ratio [i]:	1:1
	Torque max [Nm]:	25
	Rotation max [1/min]:	6000
	Rotating direction:	opposite
	Coolant:	IC/Ext
	Pressure max [bar]:	25
	Please note:	180° reversible
	Center distance [mm]:	50
	Offset [mm]:	35
<b>8 043 44 005</b>	<b>Universal head +105°/-20° adj. ER16 AX UT</b>	
	Weight [kg]:	5.360
	Notation:	offset; 180° reversible
	Tool drive:	Flat (~DIN 1809)
	Shank size [mm]:	45.00
	Shank type:	BMT
	Tool adaption:	ER 16 A - u-tec
	Gear ratio [i]:	1:1
	Torque max [Nm]:	25



Part-#	Name	
	Rotation max [1/min]:	6000
	Rotating direction:	opposite
	Coolant:	EXT
	Center distance [mm]:	50
	Offset [mm]:	35
<b>8 043 44 006</b>	<b>Universal head +105°/-20° adj. ER16AX UTIK</b>	
	Weight [kg]:	5.470
	Notation:	offset
	Tool drive:	Flat (~DIN 1809)
	Shank size [mm]:	45.00
	Shank type:	BMT
	Tool adaption:	ER 16 A - u-tec
	Gear ratio [i]:	1:2
	Torque max [Nm]:	12
	Rotation max [1/min]:	12000
	Rotating direction:	opposite
	Coolant:	IC/Ext
	Pressure max [bar]:	25
	Please note:	180° reversible
	Center distance [mm]:	50
	Offset [mm]:	35
<b>8 043 44 007</b>	<b>Universal head +105°/-20° adj. ER16 AX UT</b>	
	Weight [kg]:	5.410
	Notation:	offset
	Tool drive:	Flat (~DIN 1809)
	Shank size [mm]:	45.00
	Shank type:	BMT
	Tool adaption:	ER 16 A - u-tec
	Gear ratio [i]:	1:2
	Torque max [Nm]:	12
	Rotation max [1/min]:	12000
	Rotating direction:	opposite
	Coolant:	EXT
	Please note:	180° reversible
	Center distance [mm]:	50
	Offset [mm]:	35
<b>8 043 44 042</b>	<b>Universal head +105°/-20° adj. ER16AX UTIK</b>	
	Weight [kg]:	5.470
	Notation:	offset
	Version:	at 71,5° position can be pinned
	Tool drive:	Flat (~DIN 1809)
	Shank size [mm]:	45.00
	Shank type:	BMT
	Tool adaption:	ER 16 A - u-tec
	Gear ratio [i]:	1:1
	Torque max [Nm]:	25
	Rotation max [1/min]:	6000
	Rotating direction:	opposite
	Coolant:	IC/Ext
	Pressure max [bar]:	25
	Please note:	180° reversible
	Center distance [mm]:	50

Part-#	Name
--------	------

8 043 45 000



**Universal head +105°/-20° adj. ER25 AX UT**

Weight [kg]: 5.580  
 Notation: offset; 180° reversible  
 Tool drive: Flat (~DIN 1809)  
 Shank size [mm]: 45.00  
 Shank type: BMT  
 Tool adaption: ER 25 A - u-tec  
 Gear ratio [i]: 1:1  
 Torque max [Nm]: 25  
 Rotation max [1/min]: 6000  
 Rotating direction: opposite  
 Coolant: EXT  
 Please note: stronger bearing  
 Center distance [mm]: 50

8 043 45 004



**Universal head +105°/-20° adj. ER25AX UTIK**

Weight [kg]: 5.660  
 Notation: offset; 180° reversible  
 Tool drive: Flat (~DIN 1809)  
 Shank size [mm]: 45.00  
 Shank type: BMT  
 Tool adaption: ER 25 A - u-tec  
 Gear ratio [i]: 1:1  
 Torque max [Nm]: 25  
 Rotation max [1/min]: 6000  
 Rotating direction: opposite  
 Coolant: IC/Ext  
 Pressure max [bar]: 25  
 Please note: stronger bearing  
 Center distance [mm]: 50  
 Offset [mm]: 35

8 043 45 005

**Universal head +105°/-20° adj. ER25AX UTIK**

Weight [kg]: 5.610  
 Notation: offset; 180° reversible  
 Version: at 42,9° position can be pinned  
 Tool drive: Flat (~DIN 1809)  
 Shank size [mm]: 45.00  
 Shank type: BMT  
 Tool adaption: ER 25 A - u-tec  
 Gear ratio [i]: 1:1  
 Torque max [Nm]: 25  
 Rotation max [1/min]: 6000  
 Rotating direction: opposite  
 Coolant: IC/Ext  
 Pressure max [bar]: 25  
 Please note: stronger bearing  
 Center distance [mm]: 50  
 Offset [mm]: 35

8 043 45 015

**Universal head +105°/-20° adj. Weldon 16**



Notation: offset; 180° reversible  
 Tool drive: Flat (~DIN 1809)  
 Shank size [mm]: 45.00  
 Shank type: BMT  
 Tool adaption: Weldon (DIN 1835 b) 16 special  
 Gear ratio [i]: 1:1

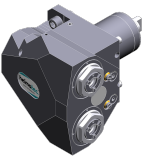

Part-#	Name	
	Torque max [Nm]:	25
	Rotation max [1/min]:	6000
	Rotating direction:	opposite
	Coolant:	EXT
	Please note:	stronger bearing
	Center distance [mm]:	50
	Offset [mm]:	35
<b>8 043 45 017</b>	<b>Universal head +105°/-20° adj. ER25 AX UT</b>	
	Weight [kg]:	5.590
	Notation:	offset; 180° reversible; at 45° position can be pinned
	Tool drive:	Flat (~DIN 1809)
	Shank size [mm]:	45.00
	Shank type:	BMT
	Tool adaption:	ER 25 A - u-tec
	Gear ratio [i]:	1:1
	Torque max [Nm]:	25
	Rotation max [1/min]:	6000
	Rotating direction:	opposite
	Coolant:	EXT
	Please note:	stronger bearing
	Center distance [mm]:	50
<b>8 043 46 002</b>	<b>Universal head +105°/-20° adj. Weldon 20</b>	
	Weight [kg]:	5.790
	Notation:	offset; 180° reversible
	Tool drive:	Flat (~DIN 1809)
	Shank size [mm]:	45.00
	Shank type:	BMT
	Tool adaption:	Weldon (DIN 1835 b) 20
	Gear ratio [i]:	1:1
	Torque max [Nm]:	25
	Rotation max [1/min]:	6000
	Rotating direction:	opposite
	Coolant:	EXT
	Please note:	stronger bearing
	Center distance [mm]:	50
	Offset [mm]:	35
<b>8 050 43 009</b>	<b>Multispindle drilling head ER 11</b>	
	Tool drive:	Flat (~DIN 1809)
	Shank size [mm]:	45.00
	Shank type:	BMT
	Tool adaption:	ER 11
	Gear ratio [i]:	1:1
	Torque max [Nm]:	10/Sp.
	Rotation max [1/min]:	6000
	Rotating direction:	opposite
	Coolant:	EXT
<b>8 050 44 005</b>	<b>Multispindle drilling head ER 16 AX UT</b>	
	Weight [kg]:	3.700
	Version:	2-spindles
	Tool drive:	Flat (~DIN 1809)
	Shank size [mm]:	45.00
	Tool adaption:	ER 16 A - u-tec
	Gear ratio [i]:	1:1



Part-#	Name	
	Torque max [Nm]:	25/Sp.
	Rotation max [1/min]:	12000
	Rotating direction:	opposite
	Coolant:	EXT
<b>8 050 44 045</b>	<b>Multispindle drilling head ER 16 AX UT</b>	
	Weight [kg]:	5.840
	Notation:	offset, 180° reversible
	Version:	2-spindles
	Tool drive:	Flat (~DIN 1809)
	Shank size [mm]:	45.00
	Shank type:	BMT
	Tool adaption:	ER 16 A - u-tec
	Gear ratio [i]:	1:2
	Torque max [Nm]:	8/Sp.
	Rotation max [1/min]:	12000
	Rotating direction:	same
	Coolant:	EXT
	Offset [mm]:	64,359
<b>8 053 44 032</b>	<b>Multispindle radial head ER 16 AX UT</b>	
	Weight [kg]:	6.120
	Notation:	180° reversible
	Version:	2-spindles
	Tool drive:	Flat (~DIN 1809)
	Shank size [mm]:	45.00
	Shank type:	BMT
	Tool adaption:	ER 16 A - u-tec
	Gear ratio [i]:	1:2
	Torque max [Nm]:	8
	Rotation max [1/min]:	12000
	Rotating direction:	same
	Coolant:	EXT
	Center distance [mm]:	65
<b>8 053 44 062</b>	<b>Multispindle radial head ER16 AX UT IC</b>	
	Weight [kg]:	6.580
	Notation:	180° reversible
	Version:	2-spindles
	Tool drive:	Flat (~DIN 1809)
	Shank size [mm]:	45.00
	Shank type:	BMT
	Tool adaption:	ER 16 A - u-tec
	Gear ratio [i]:	1:1
	Torque max [Nm]:	32/Sp
	Rotation max [1/min]:	12000
	Rotating direction:	same
	Coolant:	IC/Ext
	Pressure max [bar]:	140
	Center distance [mm]:	65

Part-#	Name	
<b>8 053 44 063</b>	<b>Multispindle radial head ER16 AX UT IC</b>	
	Notation:	180° reversible
	Version:	2-spindles
	Tool drive:	Flat (~DIN 1809)
	Shank size [mm]:	45.00
	Shank type:	BMT
	Tool adaption:	ER 16 A - u-tec
	Gear ratio [i]:	1:2
	Torque max [Nm]:	16/Sp
	Rotation max [1/min]:	12000
	Rotating direction:	same
	Coolant:	IC/Ext
	Pressure max [bar]:	140
	Center distance [mm]:	65
<b>8 053 44 065</b>	<b>Multispindle radial head ER 16 AX UT</b>	
	Weight [kg]:	6.400
	Notation:	180° reversible
	Version:	2-spindles
	Tool drive:	Flat (~DIN 1809)
	Shank size [mm]:	45.00
	Shank type:	BMT
	Tool adaption:	ER 16 A - u-tec
	Gear ratio [i]:	1:2
	Torque max [Nm]:	16/Sp
	Rotation max [1/min]:	12000
	Rotating direction:	same
	Coolant:	EXT
	Center distance [mm]:	65
<b>8 053 44 066</b>	<b>Multispindle radial head ER 16 AX UT</b>	
	Notation:	180° reversible
	Version:	2-spindles
	Tool drive:	Flat (~DIN 1809)
	Shank size [mm]:	45.00
	Shank type:	BMT
	Tool adaption:	ER 16 A - u-tec
	Gear ratio [i]:	1:1
	Torque max [Nm]:	32/Sp
	Rotation max [1/min]:	12000
	Rotating direction:	same
	Coolant:	EXT
	Center distance [mm]:	65
<b>8 053 44 067</b>	<b>Multispindle radial head ER 20 AX UT</b>	
	Notation:	180° reversible
	Version:	2-spindles
	Tool drive:	Flat (~DIN 1809)
	Shank size [mm]:	45.00
	Shank type:	BMT
	Tool adaption:	ER 20 A - u-tec
	Gear ratio [i]:	1:1
	Torque max [Nm]:	32/Sp
	Rotation max [1/min]:	12000
	Rotating direction:	same
	Coolant:	EXT
	Please note:	Check applicability; note tool length!

Part-#	Name	
	Center distance [mm]:	75
<b>8 053 44 074</b>	<b>Multispindle radial head ER 20 AX UTIK</b>	
	Notation:	180° reversible
	Version:	2-spindles
	Tool drive:	Flat (~DIN 1809)
	Shank size [mm]:	45.00
	Shank type:	BMT
	Tool adaption:	ER 20 A - u-tec
	Gear ratio [i]:	1:1
	Torque max [Nm]:	32/Sp
	Rotation max [1/min]:	12000
	Rotating direction:	same
	Coolant:	IC/Ext
	Pressure max [bar]:	140
	Please note:	Check applicability; note tool length!
	Center distance [mm]:	75
<b>8 200 02 001</b>	<b>Cover plate</b>	
	Weight [kg]:	0.320
	Shank type:	-
<b>8 202 00 010</b>	<b>Basic holder longitudinal seat FN 12</b>	
	Weight [kg]:	0.920
	Notation:	180° reversible
	Shank type:	BMT
	Machine adaption:	Centering bolt ø 12
	Tool adaption:	Interface FN 12
	Coolant:	EXT
<b>8 224 01 020</b>	<b>Cut-off holder sq. 20</b>	
	Weight [kg]:	2.020
	Employment for:	right cutting tools
	Version:	Special; edge on side of turret
	Shank type:	BMT
	Machine adaption:	Centering bolt ø 12
	Tool adaption:	Sq. 20
	Coolant:	EXT
<b>8 224 03 016</b>	<b>Universal turning holder sq. 3/4" IC</b>	
	Weight [kg]:	2.630
	Notation:	180° reversible
	Shank type:	BMT
	Machine adaption:	Centering bolt ø 12
	Tool adaption:	Sq. 3/4" (19,05mm)
		Sq. 3/4" (19,05mm)
	Coolant:	IC/Ext
	Pressure max [bar]:	100
	Please note:	Key rail

Part-#	Name	
<b>8 224 04 000</b>	<b>Universal turning holder sq. 20</b>	
	Weight [kg]:	2.640
	Notation:	180° reversible
	Shank type:	BMT
	Machine adaption:	Centering bolt ø 12
	Tool adaption:	Sq. 20
		Sq. 20
	Coolant:	EXT
<b>8 224 04 035</b>	<b>Universal turning holder sq. 20 IC</b>	
	Weight [kg]:	2.620
	Notation:	180° reversible
	Shank type:	BMT
	Machine adaption:	Centering bolt ø 12
	Tool adaption:	Sq. 20
	Coolant:	IC
<b>8 224 04 068</b>	<b>Universal turning holder sq. 20 IC</b>	
	Weight [kg]:	2.610
	Notation:	180° reversible
	Shank type:	BMT
	Machine adaption:	Centering bolt ø 12
	Tool adaption:	Sq. 20
		Sq. 20
	Coolant:	IC/Ext
	Pressure max [bar]:	100
	Please note:	Key rail
<b>8 229 05 004</b>	<b>Tool holder C 3 IC</b>	
	Weight [kg]:	2.980
	Notation:	180° reversible
	Version:	right
	Shank type:	BMT
	Machine adaption:	Centering bolt ø 12
	Tool adaption:	heimatec Capto(TM) C 3
	Coolant:	IC
	Please note:	Check applicability; note tool length!
	Offset [mm]:	65
<b>8 229 05 005</b>	<b>Tool holder C 3 IC</b>	
	Weight [kg]:	1.590
	Notation:	180° reversible
	Version:	right
	Shank type:	BMT
	Machine adaption:	Centering bolt ø 12
	Tool adaption:	heimatec Capto(TM) C 3
	Coolant:	IC
	Please note:	Check applicability; note tool length!
	Offset [mm]:	27

Part-#	Name	
<b>8 240 05 034</b>	<b>Boring bar holder Ø 16</b>	
	Weight [kg]:	4.360
	Notation:	180° reversible
	Shank type:	BMT
	Machine adaption:	Centering bolt ø 12
	Tool adaption:	Ø 16
	Coolant:	IC/Ext
	Center distance [mm]:	75
<b>8 240 05 059</b>	<b>Tool holder C 3 IC</b>	
	Weight [kg]:	4.130
	Notation:	180° reversible
	Version:	right
	Shank type:	BMT
	Machine adaption:	Centering bolt ø 12
	Tool adaption:	heimatec Capto(TM) C 3
	Coolant:	IC
	Please note:	Check applicability; note tool length!
	Center distance [mm]:	80
<b>8 240 05 060</b>	<b>Tool holder C 3 IC</b>	
	Weight [kg]:	3.190
	Notation:	180° reversible
	Version:	offset; right
	Shank type:	BMT
	Machine adaption:	Centering bolt ø 12
	Tool adaption:	heimatec Capto(TM) C 3
	Coolant:	IC
	Please note:	Check applicability; note tool length!
	Center distance [mm]:	80
<b>8 240 06 034</b>	<b>Boring bar holder Ø 20</b>	
	Weight [kg]:	4.280
	Notation:	180° reversible
	Shank type:	BMT
	Machine adaption:	Centering bolt ø 12
	Tool adaption:	Ø 20
	Coolant:	IC/Ext
	Center distance [mm]:	75
<b>8 240 07 038</b>	<b>Boring bar holder Ø 25</b>	
	Weight [kg]:	4.160
	Notation:	180° reversible
	Shank type:	BMT
	Machine adaption:	Centering bolt ø 12
	Tool adaption:	Ø 25
	Coolant:	IC/Ext
	Center distance [mm]:	75
<b>8 240 07 050</b>	<b>Boring bar holder Ø 1 1/4 "</b>	
	Weight [kg]:	3.790
	Notation:	offset
	Shank type:	BMT
	Machine adaption:	Centering bolt ø 12
	Tool adaption:	Ø 1 1/4" (31,75mm)
	Coolant:	IC/Ext
	Center distance [mm]:	75

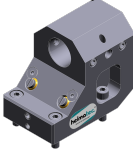
Part-#	Name	
8 240 08 000	<b>Boring bar holder Ø 32</b> 	Weight [kg]: 3.740
		Notation: offset
8 240 08 046	<b>Boring bar holder Ø 32</b>	Shank type: BMT
		Machine adaption: Centering bolt ø 12
		Tool adaption: Ø 32
		Coolant: IC/Ext
		Center distance [mm]: 75
		Weight [kg]: 3.940
		Notation: 180° reversible
8 240 08 074	<b>Boring bar holder Ø 1 1/2"</b>	Shank type: BMT
		Machine adaption: Centering bolt ø 12
		Tool adaption: Ø 1 1/2" (38,1mm)
		Coolant: IC/Ext
		Center distance [mm]: 75
		Weight [kg]: 4.000
		Notation: BMT
8 240 09 002	<b>Boring bar holder Ø 40</b> 	Machine adaption: Centering bolt Ø 12
		Tool adaption: Ø 40
		Coolant: IC/Ext
		Center distance [mm]: 75
		Weight [kg]: 2.660
		Version: offset
		Shank type: BMT
8 240 09 013	<b>Boring bar holder Ø 40</b>	Machine adaption: Centering bolt Ø 12
		Tool adaption: Ø 40
		Coolant: IC/Ext
		Center distance [mm]: 75
		Weight [kg]: 3.950
		Shank type: BMT
		Notation: Centering bolt Ø 12
8 244 04 019	<b>Combi facing holder sq. 20</b>	Machine adaption: Centering bolt ø 12
		Tool adaption: Sq. 20
		Coolant: EXT
		Weight [kg]: 3.700
		Shank type: BMT
8 249 05 008	<b>Double tool holder C 3 IC</b>	Machine adaption: Centering bolt ø 12
		Tool adaption: heimatec Capto(TM) C 3
		Weight [kg]: 4.860
		Employment for: Main- and sub spindle
		Version: right
		Shank type: BMT

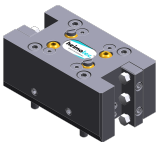
Part-#	Name	
		heimatec Capto(TM) C 3 IC Check applicability; note tool length! 80
<b>8 250 05 002</b>	<b>Multiple tool holder C 3 IC</b>	
	Coolant:	
	Please note:	
	Center distance [mm]:	
	Weight [kg]:	2.140
	Employment for:	Main- and sub spindle
	Version:	right
	Shank type:	BMT
	Machine adaption:	Centering bolt ø 12
	Tool adaption:	heimatec Capto(TM) C 3 heimatec Capto(TM) C 3
	Coolant:	IC
	Please note:	Check applicability; note tool length!
	Offset [mm]:	27 27
<b>8 250 05 003</b>	<b>Multiple tool holder C 3 IC</b>	
	Weight [kg]:	3.730
	Employment for:	Main- and sub spindle
	Version:	right
	Shank type:	BMT
	Machine adaption:	Centering bolt ø 12
	Tool adaption:	heimatec Capto(TM) C 3 heimatec Capto(TM) C 3
	Coolant:	IC
	Please note:	Check applicability; note tool length!
	Offset [mm]:	65 65
<b>8 251 03 002</b>	<b>Combi double turning holder sq. 3/4"IC</b>	
	Weight [kg]:	4.360
	Notation:	180° reversible
	Shank type:	BMT
	Machine adaption:	Centering bolt ø 12
	Tool adaption:	Sq. 3/4" (19,05mm) Sq. 3/4" (19,05mm) Sq. 3/4" (19,05mm) Sq. 3/4" (19,05mm)
	Coolant:	IC/Ext
	Pressure max [bar]:	100
	Please note:	Key rail
<b>8 251 04 002</b>	<b>Combi double turning holder sq. 20</b>	
	Weight [kg]:	4.380
	Notation:	180° reversible
	Shank type:	BMT
	Machine adaption:	Centering bolt ø 12
	Tool adaption:	Sq. 20 Sq. 20 Sq. 20 Sq. 20
	Coolant:	EXT

Part-#	Name	
<b>8 251 04 003</b>	<b>Combi double turning holder sq. 3/4"</b>	
	Weight [kg]:	4.410
	Notation:	180° reversible
	Shank type:	BMT
	Machine adaption:	Centering bolt $\varnothing$ 12
	Tool adaption:	Sq. 3/4" (19,05mm)
		Sq. 3/4" (19,05mm)
		Sq. 3/4" (19,05mm)
		Sq. 3/4" (19,05mm)
	Coolant:	EXT
<b>8 251 04 059</b>	<b>Combi double turning holder sq. 20 IC</b>	
	Weight [kg]:	4.360
	Notation:	180° reversible
	Shank type:	BMT
	Machine adaption:	Centering bolt $\varnothing$ 12
	Tool adaption:	Sq. 20
		Sq. 20
		Sq. 20
		Sq. 20
	Coolant:	IC/Ext
	Pressure max [bar]:	100
	Please note:	Key rail
<b>8 253 07 000</b>	<b>Double boring bar holder <math>\varnothing</math> 25</b>	
	Weight [kg]:	2.320
	Notation:	offset, 180° reversible
	Shank type:	BMT
	Machine adaption:	Centering bolt $\varnothing$ 12
	Tool adaption:	$\varnothing$ 25
		$\varnothing$ 25
	Coolant:	IC/Ext
	Center distance [mm]:	50/85
<b>8 253 07 003</b>	<b>Multiple boring bar holder <math>\varnothing</math> 1"</b>	
	Weight [kg]:	2.530
	Notation:	offset, 180° reversible
	Shank type:	BMT
	Machine adaption:	Centering bolt $\varnothing$ 12
	Tool adaption:	$\varnothing$ 1" (25,4mm)
		$\varnothing$ 1" (25,4mm)
	Coolant:	IC/Ext
	Center distance [mm]:	50/85
<b>8 253 07 004</b>	<b>Double boring bar holder <math>\varnothing</math> 1"</b>	
	Weight [kg]:	3.740
	Notation:	180° reversible
	Shank type:	BMT
	Machine adaption:	Centering bolt $\varnothing$ 12
	Tool adaption:	$\varnothing$ 1" (25,4mm)
		$\varnothing$ 1" (25,4mm)
	Coolant:	IC/Ext
	Center distance [mm]:	50/85

Part-#	Name			
8 253 07 006	<b>Double boring bar holder Ø 25</b>	Weight [kg]: 3.710		
		Notation: 180° reversible		
		Shank type: BMT		
		Machine adaption: Centering bolt Ø 12		
		Tool adaption: Ø 25		
		Ø 25		
		Coolant: IC/Ext		
		Center distance [mm]: 50/85		
		8 259 01 006	<b>Multiple turning holder 4x sq. 20</b>	4.700
				Weight [kg]: 4.700
				Employment for: Main- and sub spindle
				Version: Y-axes offset
Shank type: BMT				
Machine adaption: Centering bolt ø 12				
Tool adaption: Sq. 20				
Sq. 20				
Sq. 20				
Sq. 20				
Coolant: EXT				
8 259 05 001	<b>Multiple tool holder C 3 IC</b>	5.590		
		Weight [kg]: 5.590		
		Employment for: Main- and sub spindle		
		Version: right; Y-axes offset		
		Shank type: BMT		
		Machine adaption: Centering bolt ø 12		
		Tool adaption: heimatec Capto(TM) C 3		
		heimatec Capto(TM) C 3		
		heimatec Capto(TM) C 3		
		heimatec Capto(TM) C 3		
		Coolant: IC		
Please note: Check applicability; note tool length! not				
Offset [mm]: 65				
65				
8 259 05 002	<b>Multiple tool holder C 3 IC</b>	6.330		
		Weight [kg]: 6.330		
		Employment for: Main- and sub spindle		
		Version: right; Y-axes offset		
		Shank type: BMT		
		Machine adaption: Centering bolt ø 12		
		Tool adaption: heimatec Capto(TM) C 3		
		heimatec Capto(TM) C 3		
		heimatec Capto(TM) C 3		
		heimatec Capto(TM) C 3		
		Coolant: IC		
Please note: Check applicability; note tool length!				
Center distance [mm]: 80				

Part-#	Name	
<b>8 259 05 003</b>	<b>Multiple tool holder C 3 IC</b>	
	Notation:	180° reversible
	Version:	right; Y-axes offset
	Shank type:	BMT
	Machine adaption:	Centering bolt ø 12
	Tool adaption:	heimatec Capto(TM) C 3 heimatec Capto(TM) C 3
	Coolant:	IC
	Please note:	Check applicability; note tool length!
	Center distance [mm]:	80
	Offset [mm]:	+32 -32
<b>8 259 05 004</b>	<b>Multiple tool holder C 3 IC</b>	
	Weight [kg]:	4.390
	Notation:	180° reversible
	Version:	right; offset; Y-axes offset
	Shank type:	BMT
	Machine adaption:	Centering bolt ø 12
	Tool adaption:	heimatec Capto(TM) C 3 heimatec Capto(TM) C 3
	Coolant:	IC
	Please note:	Check applicability; note tool length!
	Center distance [mm]:	80
<b>8 259 05 005</b>	<b>Multiple tool holder C 3 IC</b>	
	Weight [kg]:	4.210
	Employment for:	Main- and sub spindle
	Version:	right; Y-axes offset
	Shank type:	BMT
	Machine adaption:	Centering bolt ø 12
	Tool adaption:	heimatec Capto(TM) C 3 heimatec Capto(TM) C 3 heimatec Capto(TM) C 3 heimatec Capto(TM) C 3
	Coolant:	IC
	Please note:	Check applicability; note tool length!; not
	Offset [mm]:	27 27
<b>8 259 05 006</b>	<b>Multiple tool holder C 3 IC</b>	
	Weight [kg]:	2.840
	Notation:	180° reversible
	Version:	right; Y-axes offset
	Shank type:	BMT
	Machine adaption:	Centering bolt ø 12
	Tool adaption:	heimatec Capto(TM) C 3 heimatec Capto(TM) C 3
	Coolant:	IC
	Please note:	Check applicability; note tool length!
	Offset [mm]:	27

Part-#	Name	
8 259 05 007	<b>Multiple tool holder C 3 IC</b>	
		
	Weight [kg]:	4.000
	Notation:	180° reversible
	Version:	right; Y-axes offset
	Shank type:	BMT
	Machine adaption:	Centering bolt ø 12
	Tool adaption:	heimatec Capto(TM) C 3 heimatec Capto(TM) C 3
	Coolant:	IC
	Pressure max [bar]:	100
	Please note:	Check applicability; note tool length!
	Offset [mm]:	65
8 259 09 001	<b>Multiple holder ø25 and sq. 20</b>	
	Weight [kg]:	3.980
	Notation:	180° reversible
	Shank type:	BMT
	Machine adaption:	Centering bolt ø 12
	Tool adaption:	ø25/ sq. 20 ø25/ sq. 20
	Coolant:	IC/Ext
	Center distance [mm]:	50/85
8 261 08 000	<b>Tool holder for centering insert</b>	
	Weight [kg]:	5.270
	Notation:	180° reversible
	Shank type:	BMT
	Machine adaption:	Centering bolt Ø 12
	Tool adaption:	Ø 32
	Coolant:	EXT
	Please note:	Price without centering point
	Center distance [mm]:	55
8 263 09 000	<b>Tool holder with rotating centering point</b>	
	Weight [kg]:	4.070
	Notation:	180° reversible
	Shank type:	BMT
	Machine adaption:	Centering bolt ø 12
	Rotation max [1/min]:	6000
	Coolant:	EXT
	Please note:	Taper roller bearings
	Center distance [mm]:	75
8 263 09 007	<b>Tool holder with rotating centering point</b>	
	Weight [kg]:	6.410
	Notation:	180° reversible; offset
	Shank type:	BMT
	Machine adaption:	Centering bolt ø 12
	Rotation max [1/min]:	6000
	Coolant:	EXT
	Center distance [mm]:	85

Part-#	Name	
<b>8 320 02 017</b>	<b>Cut-off holder, height adjustable SH 26 IC</b>	
	Weight [kg]:	1.410
	Notation:	180° reversible
	Shank type:	BMT
	Machine adaption:	Centering bolt ø 12
	Tool adaption:	Clampshaft SH 26
	Coolant:	IC/Ext
	Pressure max [bar]:	70
<b>8 320 02 018</b>	<b>Cut-off holder, height adjustable SH 26 IC</b>	
	Weight [kg]:	1.560
	Notation:	180° reversible
	Shank type:	BMT
	Machine adaption:	Centering bolt ø 12
	Tool adaption:	Clampshaft SH 26
	Coolant:	IC/Ext
	Pressure max [bar]:	70
	Please note:	Clampshaft internal
<b>8 320 09 003</b>	<b>Cut-off holder, height adjustable 845 IC</b>	
	Weight [kg]:	1.390
	Notation:	180° reversible
	Shank type:	BMT
	Machine adaption:	Centering bolt ø 12
	Tool adaption:	 System 845
	Coolant:	IC
	Pressure max [bar]:	70

## heimatec.u-tec®

heimatec.com

Products / Tool change systems /  
u-tec® Tool-changing system



versions see catalog



## heimatec.easy-quick

heimatec.com

Products / Tool change systems /  
easy-quick HT quick-changing system



versions see catalog

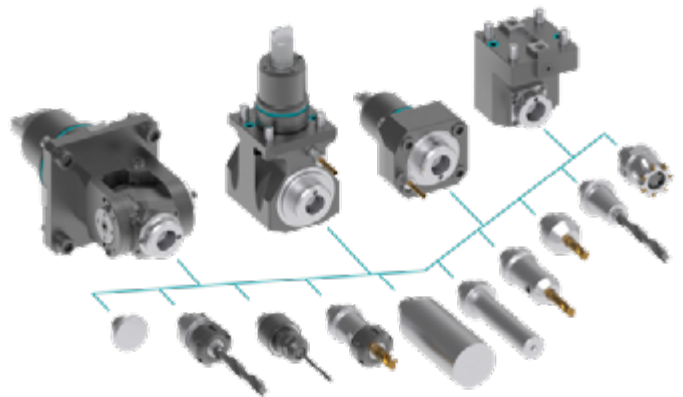

## heimatec.Capto™

heimatec.com

Products / Tool change systems /  
heimatec.Capto™ quick-changing system



versions see catalog

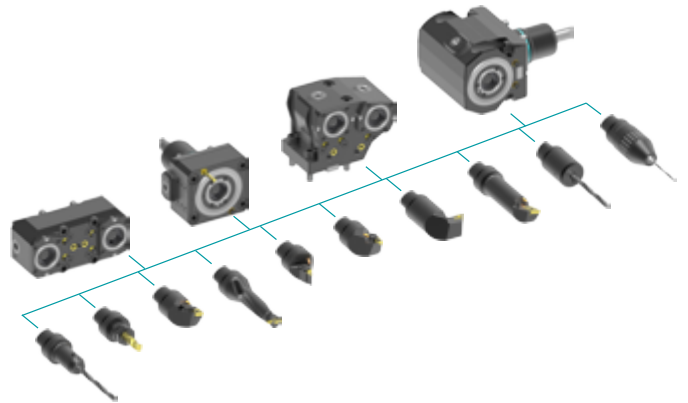

## heimatec.accessories

heimatec.com

Products / Accessories



versions see catalog





● heimatec overseas branches

○ global representations of heimatec

**heimatec**<sup>®</sup>

**heimatec GmbH**  
Präzisionswerkzeuge  
Carl-Benz-Str. 4  
77871 Renchen  
Germany

T +49 7843 9466 0  
[www.heimatec.com](http://www.heimatec.com)  
[info@heimatec.com](mailto:info@heimatec.com)

Please find the contact details of our worldwide trading partners on our website:  
<https://heimatec.com/business-partners>