

Axial-Bohr- und Fräskopf

Axial drilling and milling head

Tête de perçage et de fraisage axiale

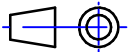

Darstellung symbolisch
symbolical drawing
schéma symbolique

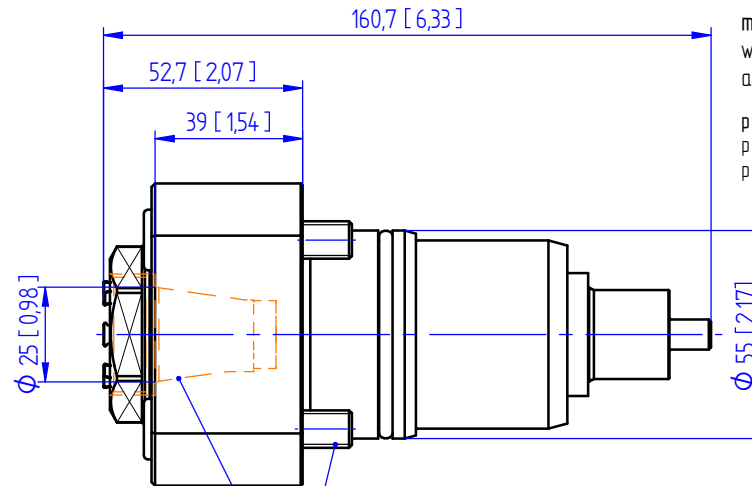
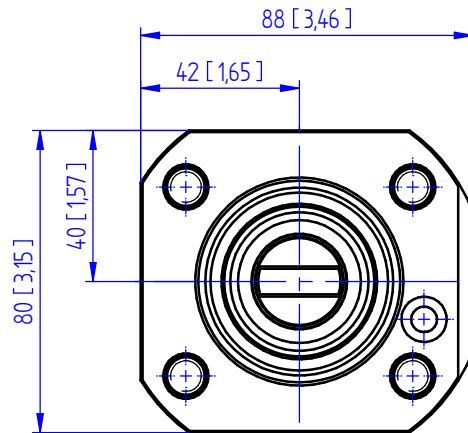

$n_2 = +n_1$



Trockenlauf möglich
dryrun possible
Possibilité d'un fonctionnement à sec

mit innerer Kühlmittelzufuhr für Hochdruck
internal coolant supply (for high pressure)
arrosage interne (pour haute pression)

mit kombinierter Kühlmittelzufuhr
with combined coolant supply
arrosage combiné

p x n Diagramm D 00 017
p x n diagram D 00 017
p x n diagramme D 00 017

Optionen : bei externer Kühlmittelzufuhr Verschlusschraube durch Kühlrohr ersetzen
options : using external coolant supply, please substitute locking screw by coolant tube
options : pour arrosage externe, remplacez la vis par le tube fileté

ER 25 A UT (0,5 [0,020] - 16,0 [0,630])

Befestigungsschrauben
fastening screws
vis de fixation



Dichtscheiben
sealings
joints



Spannzangen
collets
les pinces



Bedienschlüsselsatz
set of wrench
jeu de clés



Wechseleinsatz u-tec
insert u-tec
insert u-tec

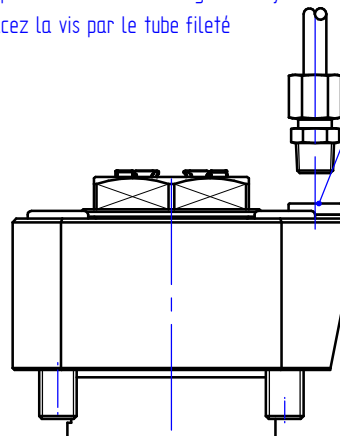

» weitere Ausführungen auf Anfrage
other models on request
autres modèles sur demande
subject to technical changes

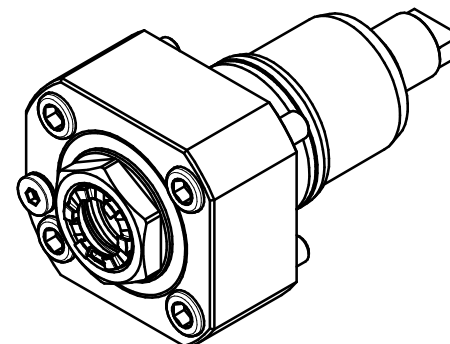

p max. [bar/psi] = 100 / 1450

i = 1:1

M₂ max. [Nm] = 50

n₂ max. [min⁻¹] = 15000

Bestell - Nr.
ref.no. / No.de cde.

8 010 55 111

nous nous réservons toutes modifications techniques