

Citizen
Cincom M16



High-tech from heimatec - heimatec - Tools and systems for productive turning and milling

heimatec belongs to the international technology and quality leaders for precision tools and specializes in the development and production of high-precision static and live tools for all CNC lathes, CNC turn-/mill machines and CNC machining centers.

The range of products* spans from static BMT and VDI tool holders, live tools up to highly complex customer-specific individual solutions. heimatec, headquartered in Renchen, has a own subsidiary in Asia and India and numerous representatives as well as trading partners all over the world.

*OUR PRODCUTS

Static tool holders

Live tool units

Precision tools

Tools for turning and machining centres

Tools for swiss type lathes

Tool changing and uick-change systems

Tool systems for gear production

Digital tool management

This catalogue, including all its parts, is protected by copyright. Any use outside the restricted limitations of the Copyright Act without the consent of heimatec is inadmissible and liable to prosecution. This applies in particular to duplication, translation, microfilming and storage and processing in electronic systems.

heimatec GmbH reserves the right to make technical changes at any time without giving prior notice. This applies in particular to adjustments at any time to meet new or changed international standards, or in case of further developments of our products or manufacturing processes.

The current version of our General Terms and Conditions can be found on our website.

Part-#	Name
--------	------

3 010 23 000

Axial drilling and milling head ER 11



Citizen Part-#: MSC507
 Weight [kg]: 0.360
 Tool drive: Gear
 Shank size [mm]: 25.00
 Shank type: BMT
 Tool adaption: ER 11
 Gear ratio [i]: 1:1
 Torque max [Nm]: 10
 Rotation max [1/min]: 10000
 Rotating direction: same
 Coolant: no
 Please note: stronger bearing

3 010 23 006

Axial drilling and milling head ER 11 IC



Weight [kg]: 0.500
 Tool drive: Gear
 Shank size [mm]: 25.00
 Shank type: BMT
 Tool adaption: ER 11
 Gear ratio [i]: 1:1
 Torque max [Nm]: 10
 Rotation max [1/min]: 10000
 Rotating direction: same
 Coolant: IC
 Pressure max [bar]: 100
 Please note: stronger bearing

3 010 24 004

Axial drilling and milling head ER 16



Weight [kg]: 0.490
 Tool drive: Gear
 Shank size [mm]: 25.00
 Shank type: BMT
 Tool adaption: ER 16
 Gear ratio [i]: 1:1
 Torque max [Nm]: 10
 Rotation max [1/min]: 10000
 Rotating direction: same
 Coolant: no

3 013 23 000

Axial drilling and milling head ER 11

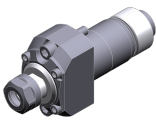

Weight [kg]: 0.360
 Tool drive: Gear
 Shank size [mm]: 25.00
 Shank type: BMT
 Tool adaption: ER 11
 Gear ratio [i]: 1:4
 Torque max [Nm]: 2,5
 Rotation max [1/min]: 48000
 Rotating direction: same
 Coolant: no

Part-#	Name	
3 224 00 000	Turning holder sq. 10	
	Citizen Part-#:	VTF110
	Weight [kg]:	0.780
	Notation:	180° reversible
	Employment for:	Turret
	Shank type:	BMT
	Machine adaption:	Centering bolt ø 10
	Tool adaption:	Sq. 10
	Coolant:	no
	Offset [mm]:	63,5 (0)
3 240 05 000	Boring bar holder ø 3/4"	
	Citizen Part-#:	VDF101
	Weight [kg]:	1.070
	Notation:	180° reversible
	Employment for:	Turret
	Version:	offset
	Shank type:	BMT
	Machine adaption:	Centering bolt ø 10
	Tool adaption:	Ø 3/4" (19,05mm)
	Coolant:	no
	Center distance [mm]:	45
	Offset [mm]:	8,5 (55)
3 253 05 000	Multiple boring bar holder ø 3/4"	
	Citizen Part-#:	VDF401
	Weight [kg]:	1.350
	Notation:	180° reversible
	Employment for:	Turret
	Version:	offset
	Shank type:	BMT
	Machine adaption:	Centering bolt ø 10
	Tool adaption:	Ø 3/4" (19,05mm) Ø 3/4" (19,05mm)
	Coolant:	no
	Center distance [mm]:	45/67,5
	Offset [mm]:	8,5 (55)
3 253 25 000	Multiple boring bar holder Ø 3/4"	
	Citizen Part-#:	MDF107
	Weight [kg]:	2.870
	Notation:	offset
	Shank size [mm]:	25.00
	Shank type:	BMT
	Tool adaption:	Ø 3/4" (19,05mm) Ø 3/4" (19,05mm) Ø 3/4" (19,05mm)
	Coolant:	no
	Center distance [mm]:	66/101/136

Part-#	Name	
3 253 25 001	Multiple boring bar holder Ø 3/4"	
	Citizen Part-#:	GDF1302
	Notation:	offset
	Shank size [mm]:	25.00
	Shank type:	BMT
	Tool adaption:	Ø 3/4" (19,05mm)
		Ø 3/4" (19,05mm)
		Ø 3/4" (19,05mm)
	Coolant:	no
	Center distance [mm]:	62/ 85/108
3 253 25 002	Multiple boring bar holder Ø 3/4"	
	Citizen Part-#:	GDF1303
	Weight [kg]:	1.700
	Notation:	offset
	Shank size [mm]:	25.00
	Shank type:	BMT
	Tool adaption:	Ø 3/4" (19,05mm)
		Ø 3/4" (19,05mm)
		Ø 3/4" (19,05mm)
	Coolant:	no
	Center distance [mm]:	60,5/ 90,5/120,5
3 776 13 000	Collet chuck Ø 19,05/ER 11	
	Citizen Part-#:	BDS507
	Weight [kg]:	0.110
	Shank size [mm]:	19.05
	Tool adaption:	ER 11
	Coolant:	no
	Please note:	Total length 61,3 mm
3 776 13 001	Collet chuck Ø 19,05/ER 11	
	Citizen Part-#:	BDS607
	Weight [kg]:	0.120
	Version:	long L
	Shank size [mm]:	19.05
	Tool adaption:	ER 11
	Coolant:	no
	Please note:	Total length 73,3 mm
3 776 13 002	Collet chuck Ø 19,05/ER 11	
	Citizen Part-#:	BDS707
	Weight [kg]:	0.090
	Version:	short S
	Shank size [mm]:	19.05
	Tool adaption:	ER 11
	Coolant:	no
	Please note:	Total length 54,3 mm

Part-#	Name	
3 776 13 003	Collet chuck Ø 19,05/ER 11	
	Citizen Part-#:	VDS506
	Weight [kg]:	0.142
	Version:	long XL
	Shank size [mm]:	19.05
	Tool adaption:	ER 11
	Coolant:	no
	Please note:	Total length 84,8 mm
3 776 13 005	Doppel-collet chuck Ø 19,05/ER 11	
	Citizen Part-#:	HDS5506
	Weight [kg]:	0.100
	Version:	long L
	Shank size [mm]:	19.05
	Tool adaption:	ER 11
		ER 11
	Coolant:	no
	Please note:	Total length 85,0 mm
3 776 14 000	Collet chuck Ø 19,05/ER 16	
	Citizen Part-#:	BDS508
	Weight [kg]:	0.112
	Shank size [mm]:	19.05
	Tool adaption:	ER 16
	Coolant:	no
	Please note:	Total length 65,3 mm
3 776 14 001	Collet chuck Ø 19,05/ER 16	
	Citizen Part-#:	BDS610
	Weight [kg]:	0.120
	Version:	long L
	Shank size [mm]:	19.05
	Tool adaption:	ER 16
	Coolant:	no
	Please note:	Total length 80,3 mm
3 776 14 003	Collet chuck Ø 19,05/ER 16	
	Citizen Part-#:	VDS110
	Weight [kg]:	0.140
	Version:	long XL
	Shank size [mm]:	19.05
	Tool adaption:	ER 16
	Coolant:	no
	Please note:	Total length 90,0 mm
3 778 13 000	Tapping chuck Ø 19,05/ER 11	
	Citizen Part-#:	BNS407
	Notation:	with length compensation 8 mm
	Version:	short S
	Shank size [mm]:	19.05
	Tool adaption:	ER 11
	Coolant:	no
	Please note:	incl. per 1x Schneideisenaufnahme ø16x5 / 86,0 mm and

heimatec.u-tec®

heimatec.com

Products / Tool change systems /
u-tec® Tool-changing system



versions see catalog



heimatec.easy-quick

heimatec.com

Products / Tool change systems /
easy-quick HT quick-changing system



versions see catalog



heimatec.Capto™

heimatec.com

Products / Tool change systems /
heimatec.Capto™ quick-changing system



versions see catalog

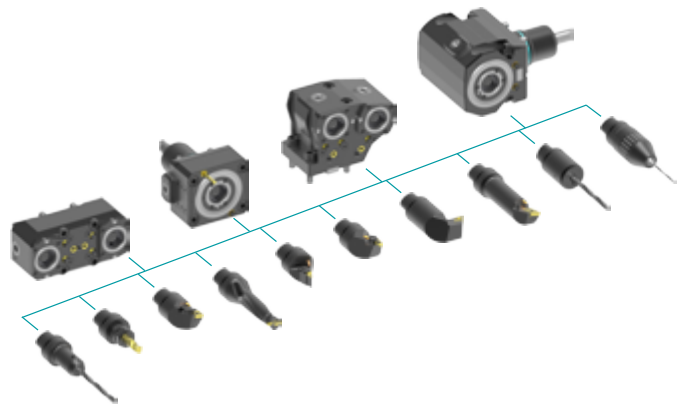

heimatec.accessories

heimatec.com

Products / Accessories



versions see catalog





● heimatec overseas branches

○ global representations of heimatec

heimatec[®]

heimatec GmbH
Präzisionswerkzeuge
Carl-Benz-Str. 4
77871 Renchen
Germany

T +49 7843 9466 0
www.heimatec.com
info@heimatec.com

Please find the contact details of our worldwide trading partners on our website:
<https://heimatec.com/business-partners>