

Mori Seiki

NZX 1500 - BMT
40



High-tech from heimatec - heimatec - Tools and systems for productive turning and milling

heimatec belongs to the international technology and quality leaders for precision tools and specializes in the development and production of high-precision static and live tools for all CNC lathes, CNC turn-/mill machines and CNC machining centers.

The range of products* spans from static BMT and VDI tool holders, live tools up to highly complex customer-specific individual solutions. heimatec, headquartered in Renchen, has a own subsidiary in Asia and India and numerous representatives as well as trading partners all over the world.

*OUR PRODCUTS

Static tool holders

Live tool units

Precision tools

Tools for turning and machining centres

Tools for swiss type lathes

Tool changing and uick-change systems

Tool systems for gear production



Digital tool management

This catalogue, including all its parts, is protected by copyright. Any use outside the restricted limitations of the Copyright Act without the consent of heimatec is inadmissible and liable to prosecution. This applies in particular to duplication, translation, microfilming and storage and processing in electronic systems.

heimatec GmbH reserves the right to make technical changes at any time without giving prior notice. This applies in particular to adjustments at any time to meet new or changed international standards, or in case of further developments of our products or manufacturing processes.

The current version of our General Terms and Conditions can be found on our website.

Part-#	Name	
8 010 45 177	Axial drilling and milling head ER 25 AS UT IC	
	Weight [kg]:	3.540
	Tool drive:	Flat (~DIN 1809)
	Shank size [mm]:	40.00
	Shank type:	BMT
	Tool adaption:	ER 25 A - u-tec
	Gear ratio [i]:	1:1
	Torque max [Nm]:	50
	Rotation max [1/min]:	6000
	Rotating direction:	same
	Coolant:	IC/Ext
	Pressure max [bar]:	25
8 010 45 190	Axial drilling and milling head ER 25 AS UT IC	
	Tool drive:	Flat (~DIN 1809)
	Shank size [mm]:	40.00
	Shank type:	BMT
	Tool adaption:	ER 25 A - u-tec
	Gear ratio [i]:	1:1
	Torque max [Nm]:	50
	Rotation max [1/min]:	10000
	Rotating direction:	same
	Coolant:	IC/Ext
	Pressure max [bar]:	80
	Please note:	Dryrun possible
8 010 46 158	Axial drilling and milling head ER 32 AX UT IC	
	Weight [kg]:	4.230
	Tool drive:	Flat (~DIN 1809)
	Shank size [mm]:	40.00
	Shank type:	BMT
	Tool adaption:	ER 32 A - u-tec
	Gear ratio [i]:	1:1
	Torque max [Nm]:	50
	Rotation max [1/min]:	6000
	Rotating direction:	same
	Coolant:	IC/Ext
	Pressure max [bar]:	70
	Please note:	stronger bearing
8 010 46 254	Axial drilling and milling head ER 32 AX UT IC	
	Weight [kg]:	4.230
	Tool drive:	Flat (~DIN 1809)
	Shank size [mm]:	40.00
	Shank type:	BMT
	Tool adaption:	ER 32 A - u-tec
	Gear ratio [i]:	1:1
	Torque max [Nm]:	50
	Rotation max [1/min]:	6000
	Rotating direction:	same
	Coolant:	IC/Ext
	Pressure max [bar]:	25
	Please note:	stronger bearing

Part-#	Name		
	8 010 46 279	Axial drilling and milling head C 4	
		Weight [kg]:	4.120
		Notation:	180° reversible
		Tool drive:	Flat (~DIN 1809)
		Shank size [mm]:	40.00
		Shank type:	BMT
		Tool adaption:	heimatec Capto(TM) C 4
		Gear ratio [i]:	1:1
		Torque max [Nm]:	50
		Rotation max [1/min]:	8000
		Rotating direction:	same
		Coolant:	EXT
		Please note:	Check applicability; tool length check!
	8 010 46 295	Axial drilling and milling head ER 32 AS UT	
		Weight [kg]:	2.820
		Tool drive:	Flat (~DIN 1809)
		Shank size [mm]:	40.00
		Shank type:	BMT
		Tool adaption:	ER 32 A - u-tec
		Gear ratio [i]:	1:1
		Torque max [Nm]:	50
		Rotation max [1/min]:	12000
		Rotating direction:	same
		Coolant:	EXT
		8 010 46 296	Axial drilling and milling head ER 32 AS UT IC
			Weight [kg]:
		Tool drive:	Flat (~DIN 1809)
		Shank size [mm]:	40.00
		Shank type:	BMT
		Tool adaption:	ER 32 A - u-tec
		Gear ratio [i]:	1:1
		Torque max [Nm]:	50
		Rotation max [1/min]:	6000
		Rotating direction:	same
		Coolant:	IC/Ext
		Pressure max [bar]:	25
		8 010 46 300	Axial drilling and milling head HT 4 IC
		Tool drive:	Flat (~DIN 1809)
		Shank size [mm]:	40.00
		Shank type:	BMT
		Tool adaption:	HT 4
		Gear ratio [i]:	1:1
		Torque max [Nm]:	50
		Rotation max [1/min]:	12000
		Rotating direction:	same
		Coolant:	IC/Ext
		Pressure max [bar]:	100
		Please note:	Dryrun possible

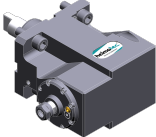
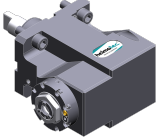

Part-#	Name	
8 010 46 306	Axial drilling and milling head ER 32 AS UT IC	
	Weight [kg]:	3.980
	Tool drive:	Flat (~DIN 1809)
	Shank size [mm]:	40.00
	Shank type:	BMT
	Tool adaption:	ER 32 A - u-tec
	Gear ratio [i]:	1:1
	Torque max [Nm]:	50
	Rotation max [1/min]:	10000
	Rotating direction:	same
	Coolant:	IC/Ext
	Pressure max [bar]:	80
	Please note:	Dryrun possible
8 013 43 000	Axial drilling and milling head ER 11	
	Weight [kg]:	0.740
	Tool drive:	Flat (~DIN 1809)
	Shank size [mm]:	40.00
	Shank type:	BMT
	Tool adaption:	ER 11
	Gear ratio [i]:	1:4
	Torque max [Nm]:	5
	Rotation max [1/min]:	48000
	Rotating direction:	same
	Coolant:	EXT
8 013 44 009	Axial drilling and milling head ER 16 AX UT	
	Weight [kg]:	2.410
	Tool drive:	Flat (~DIN 1809)
	Shank size [mm]:	40.00
	Shank type:	BMT
	Tool adaption:	ER 16 A - u-tec
	Gear ratio [i]:	1:4
	Torque max [Nm]:	5
	Rotation max [1/min]:	24000
	Rotating direction:	same
	Coolant:	EXT
8 013 44 010	Axial drilling and milling head ER 16 AX UT IC	
	Tool drive:	Flat (~DIN 1809)
	Shank size [mm]:	40.00
	Shank type:	BMT
	Tool adaption:	ER 16 A - u-tec
	Gear ratio [i]:	1:4
	Torque max [Nm]:	5
	Rotation max [1/min]:	24000
	Rotating direction:	same
	Coolant:	IC/Ext
	Pressure max [bar]:	80
8 019 45 178	Axial drilling and milling head ER 25 AX UT	
	Weight [kg]:	7.330
	Notation:	offset
	Employment for:	Main spindle
	Version:	Special
	Tool drive:	Flat (~DIN 1809)
	Shank size [mm]:	40.00

Part-#	Name	
	Shank type:	BMT
	Tool adaption:	ER 25 A - u-tec
	Gear ratio [i]:	1:1
	Torque max [Nm]:	40
	Rotation max [1/min]:	12000
	Rotating direction:	opposite
	Coolant:	EXT
	Please note:	stronger bearing
	Offset [mm]:	100
8 019 46 217	Axial drilling and milling head C 4 IC	
	Weight [kg]:	9.060
	Notation:	180° reversible
	Tool drive:	Flat (~DIN 1809)
	Shank size [mm]:	39.90
	Shank type:	BMT
	Tool adaption:	heimatec Capto(TM) C 4
	Gear ratio [i]:	1:1
	Torque max [Nm]:	50
	Rotation max [1/min]:	8000
	Rotating direction:	opposite
	Coolant:	IC/Ext
	Pressure max [bar]:	140
	Please note:	Check applicability; note tool length!
	Offset [mm]:	110
8 030 43 012	Radial drilling and milling head ER 11	
	Weight [kg]:	6.790
	Notation:	180° reversible
	Tool drive:	Flat (~DIN 1809)
	Shank size [mm]:	40.00
	Shank type:	BMT
	Tool adaption:	ER 11
	Gear ratio [i]:	1:4
	Torque max [Nm]:	5
	Rotation max [1/min]:	48000
	Rotating direction:	opposite
	Coolant:	EXT
	Center distance [mm]:	85
8 030 44 079	Radial drilling and milling head ER 16 AX UT	
	Weight [kg]:	6.860
	Notation:	180° reversible
	Tool drive:	Flat (~DIN 1809)
	Shank size [mm]:	40.00
	Shank type:	BMT
	Tool adaption:	ER 16 A - u-tec
	Gear ratio [i]:	1:4
	Torque max [Nm]:	5
	Rotation max [1/min]:	24000
	Rotating direction:	opposite
	Coolant:	EXT
	Center distance [mm]:	85

Part-#	Name
--------	------

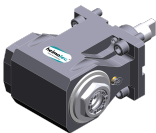

8 030 45 139	Angle-mill- and drill holder ER 25 AS UT	Weight [kg]: 6.970 Notation: 180° reversible Tool drive: Flat (~DIN 1809) Shank size [mm]: 40.00 Shank type: BMT Tool adaption: ER 25 A - u-tec Gear ratio [i]: 1:1 Torque max [Nm]: 50 Rotation max [1/min]: 6000 Rotating direction: opposite Coolant: EXT Please note: Combi bearing Center distance [mm]: 85
8 030 45 195	Radial drilling and milling head ER 25 AX UT	Weight [kg]: 6.040 Notation: 180° reversible Tool drive: Flat (~DIN 1809) Shank size [mm]: 40.00 Shank type: BMT Tool adaption: ER 25 A - u-tec Gear ratio [i]: 1:2 Torque max [Nm]: 16 Rotation max [1/min]: 12000 Rotating direction: same Coolant: EXT Please note: stronger bearing Center distance [mm]: 85
8 030 45 202	Radial drilling and milling head ER 25 AS UT	Weight [kg]: 6.940 Notation: 180° reversible Tool drive: Flat (~DIN 1809) Shank size [mm]: 40.00 Shank type: BMT Tool adaption: ER 25 A - u-tec Gear ratio [i]: 1:1 Torque max [Nm]: 50 Rotation max [1/min]: 12000 Rotating direction: opposite Coolant: EXT Center distance [mm]: 85
8 030 45 573	Radial drilling and milling head ER 25 AS UT IC	Weight [kg]: 7.640 Notation: 180° reversible Tool drive: Flat (~DIN 1809) Shank size [mm]: 40.00 Shank type: BMT Tool adaption: ER 25 A - u-tec Gear ratio [i]: 1:1 Torque max [Nm]: 50 Rotation max [1/min]: 12000 Rotating direction: opposite Coolant: IC/Ext Pressure max [bar]: 140 Center distance [mm]: 85



Part-#	Name	
8 030 45 588	Radial drilling and milling head ER 25 AS UT	
	Weight [kg]:	6.527
	Notation:	180° reversible
	Tool drive:	Flat (~DIN 1809)
	Shank size [mm]:	40.00
	Shank type:	BMT
	Tool adaption:	ER 25 A - u-tec
	Gear ratio [i]:	1:1
	Torque max [Nm]:	50
	Rotation max [1/min]:	12000
	Rotating direction:	opposite
	Coolant:	EXT
	Center distance [mm]:	85
8 030 46 320	Angle-mill- and drill holder ER 32 AS UT IC	
	Weight [kg]:	7.000
	Notation:	180° reversible
	Tool drive:	Flat (~DIN 1809)
	Shank size [mm]:	40.00
	Shank type:	BMT
	Tool adaption:	ER 32 A - u-tec
	Gear ratio [i]:	1:1
	Torque max [Nm]:	50
	Rotation max [1/min]:	6000
	Rotating direction:	opposite
	Coolant:	IC/Ext
	Pressure max [bar]:	140
	Please note:	Combi bearing
	Center distance [mm]:	85
8 031 45 058	Radial milling head universal arbor 1"	
	Weight [kg]:	7.040
	Notation:	180° reversible
	Tool drive:	Flat (~DIN 1809)
	Shank size [mm]:	40.00
	Shank type:	BMT
	Tool adaption:	Universal arbor 1" (25,4mm)
	Gear ratio [i]:	1:1
	Torque max [Nm]:	50
	Rotation max [1/min]:	8000
	Rotating direction:	opposite
	Coolant:	EXT
	Please note:	Combi bearing
	Center distance [mm]:	85
8 039 45 094	Radial drilling and milling head ER 25 AS UT	
	Weight [kg]:	6.500
	Notation:	180° reversible
	Version:	double spindle
	Tool drive:	Flat (~DIN 1809)
	Shank size [mm]:	40.00
	Shank type:	BMT
	Tool adaption:	ER 25 A - u-tec
	Gear ratio [i]:	1:1
	Torque max [Nm]:	50
	Rotation max [1/min]:	12000
	Rotating direction:	same/opposite

Part-#	Name	
	Coolant:	EXT
	Please note:	stronger bearing
	Center distance [mm]:	85
8 039 46 029	Radial drilling and milling head HT 4	
	Notation:	180° reversible
	Version:	double spindle
	Tool drive:	Flat (~DIN 1809)
	Shank size [mm]:	40.00
	Shank type:	BMT
	Tool adaption:	HT 4
	Gear ratio [i]:	1:1
	Torque max [Nm]:	50
	Rotation max [1/min]:	12000
	Rotating direction:	same/opposite
	Coolant:	EXT
	Pressure max [bar]:	140
	Please note:	stronger bearing
	Center distance [mm]:	85
8 039 46 072	Radial drilling and milling head ER 32 AS UT	
	Weight [kg]:	7.030
	Notation:	180° reversible
	Version:	double spindle
	Tool drive:	Flat (~DIN 1809)
	Shank size [mm]:	40.00
	Shank type:	BMT
	Tool adaption:	ER 32 A - u-tec
	Gear ratio [i]:	1:1
	Torque max [Nm]:	50
	Rotation max [1/min]:	12000
	Rotating direction:	same/opposite
	Coolant:	EXT
	Please note:	stronger bearing
	Center distance [mm]:	85
8 043 44 009	Universal head +105°/-20° adj. ER16 AX UT	
	Weight [kg]:	5.450
	Notation:	offset; 180° reversible
	Tool drive:	Flat (~DIN 1809)
	Shank size [mm]:	40.00
	Shank type:	BMT
	Tool adaption:	ER 16 A - u-tec
	Gear ratio [i]:	1:1
	Torque max [Nm]:	25
	Rotation max [1/min]:	6000
	Rotating direction:	opposite
	Coolant:	EXT
	Center distance [mm]:	55
	Offset [mm]:	35

Part-#	Name	
8 043 45 009	Universal head +105°/-20° adj. ER25 AX UT	
	Weight [kg]:	5.650
	Notation:	offset; 180° reversible
	Tool drive:	Flat (~DIN 1809)
	Shank size [mm]:	40.00
	Shank type:	BMT
	Tool adaption:	ER 25 A - u-tec
	Gear ratio [i]:	1:1
	Torque max [Nm]:	25
	Rotation max [1/min]:	6000
	Rotating direction:	opposite
	Coolant:	EXT
	Please note:	stronger bearing
	Center distance [mm]:	55
	Offset [mm]:	35
8 043 45 012	Universal head +105°/-20° adj. ER25 AXUTIK	
	Weight [kg]:	5.660
	Notation:	offset; 180° reversible
	Tool drive:	Flat (~DIN 1809)
	Shank size [mm]:	40.00
	Shank type:	BMT
	Tool adaption:	ER 25 A - u-tec
	Gear ratio [i]:	1:1
	Torque max [Nm]:	25
	Rotation max [1/min]:	6000
	Rotating direction:	opposite
	Coolant:	IC/Ext
	Pressure max [bar]:	25
	Please note:	stronger bearing
	Center distance [mm]:	55
	Offset [mm]:	35
8 224 04 029	Universal turning holder sq. 20	
	Weight [kg]:	4.040
	Notation:	180° reversible
	Shank size [mm]:	40.00
	Shank type:	BMT
	Machine adaption:	Centering key slot b 12
	Tool adaption:	Sq. 20
	Coolant:	EXT
	Pressure max [bar]:	80
8 224 04 044	Universal turning holder sq. 20	
	Notation:	180° reversible
	Shank size [mm]:	40.00
	Shank type:	BMT
	Machine adaption:	Centering key slot b 12
	Tool adaption:	Sq. 20
	Coolant:	EXT
	Pressure max [bar]:	80

Part-#	Name	
8 224 05 009	Universal turning holder sq. 25	
	Weight [kg]:	4.360
	Notation:	180° reversible
	Shank size [mm]:	40.00
	Shank type:	BMT
	Machine adaption:	Centering key slot b 12
	Tool adaption:	Sq. 25
	Coolant:	EXT
	Pressure max [bar]:	80
8 240 06 023	Collet chuck holder ER 32	
	Notation:	180° reversible
	Shank size [mm]:	40.00
	Shank type:	BMT
	Machine adaption:	Centering key slot b 12
	Tool adaption:	ER 32
	Coolant:	IC/Ext
	Pressure max [bar]:	80
	Center distance [mm]:	90
8 240 07 063	Boring bar holder Ø 1 1/4"	
	Weight [kg]:	6.180
	Shank size [mm]:	40.00
	Shank type:	BMT
	Machine adaption:	Centering key slot b 12
	Tool adaption:	Ø 1 1/4" (31,75mm)
	Coolant:	IC/Ext
	Pressure max [bar]:	80
	Center distance [mm]:	100
8 240 08 030	Boring bar holder Ø 32	
	Weight [kg]:	6.350
	Notation:	180° reversible
	Shank size [mm]:	40.00
	Shank type:	BMT
	Machine adaption:	Centering key slot b 12
	Tool adaption:	Ø 32
	Coolant:	IC/Ext
	Pressure max [bar]:	80
	Center distance [mm]:	100
8 240 09 020	Boring bar holder Ø 40	
	Notation:	180° reversible
	Shank size [mm]:	40.00
	Shank type:	BMT
	Machine adaption:	Centering key slot b 12
	Tool adaption:	Ø 40
	Coolant:	IC/Ext
	Pressure max [bar]:	140
	Center distance [mm]:	100

Part-#	Name	
8 244 04 009	Combi facing holder sq. 20	
	Weight [kg]:	4.380
	Notation:	180° reversible
	Shank size [mm]:	40.00
	Shank type:	BMT
	Machine adaption:	Centering key slot b 12
	Tool adaption:	Sq. 20
		Sq. 20
	Coolant:	EXT
	Pressure max [bar]:	80
	Center distance [mm]:	60
8 244 05 007	Combi facing holder sq. 25	
	Notation:	180° reversible
	Shank size [mm]:	40.00
	Shank type:	BMT
	Machine adaption:	Centering key slot b 12
	Tool adaption:	Sq. 25
		Sq. 25
	Coolant:	EXT
	Pressure max [bar]:	80
	Center distance [mm]:	60
8 249 08 003	Double boring bar holder Ø 32	
	Weight [kg]:	8.590
	Shank size [mm]:	40.00
	Shank type:	BMT
	Machine adaption:	Centering key slot b 12
	Tool adaption:	Ø 32
	Coolant:	IC/Ext
	Pressure max [bar]:	80
	Center distance [mm]:	100
8 249 09 001	Double boring bar holder Ø 40	
	Weight [kg]:	8.110
	Shank size [mm]:	40.00
	Shank type:	BMT
	Machine adaption:	Centering key slot b 12
	Tool adaption:	Ø 40
	Coolant:	IC/Ext
	Pressure max [bar]:	80
	Center distance [mm]:	100
8 251 03 005	Combi double turning holder sq. 3/4"	
	Weight [kg]:	5.740
	Shank size [mm]:	40.00
	Shank type:	BMT
	Machine adaption:	Centering key slot b 12
	Tool adaption:	Sq. 3/4" (19,05mm)
		Sq. 3/4" (19,05mm)
		Sq. 3/4" (19,05mm)
		Sq. 3/4" (19,05mm)
	Coolant:	EXT
	Pressure max [bar]:	80
	Please note:	short version; 70 mm

Part-#	Name	
8 251 04 024	Combi double turning holder sq. 20	
	Weight [kg]:	5.710
	Shank size [mm]:	40.00
	Shank type:	BMT
	Machine adaption:	Centering key slot b 12
	Tool adaption:	Sq. 20
		Sq. 20
		Sq. 20
		Sq. 20
	Coolant:	EXT
	Pressure max [bar]:	80
8 251 05 005	Combi double turning holder sq. 1"	
	Weight [kg]:	5.860
	Shank size [mm]:	40.00
	Shank type:	BMT
	Machine adaption:	Centering key slot b 12
	Tool adaption:	Sq. 1" (25,4mm)
		Sq. 1" (25,4mm)
		Sq. 1" (25,4mm)
		Sq. 1" (25,4mm)
	Coolant:	EXT
	Pressure max [bar]:	80
	Please note:	short version; 70 mm
8 251 05 006	Combi double turning holder sq. 25	
	Weight [kg]:	5.860
	Shank size [mm]:	40.00
	Shank type:	BMT
	Machine adaption:	Centering key slot b 12
	Tool adaption:	Sq. 25
		Sq. 25
		Sq. 25
		Sq. 25
	Coolant:	EXT
	Pressure max [bar]:	80
	Please note:	short version; 70 mm
8 251 45 010	Combi double turning holder sq. 25	
	Weight [kg]:	5.880
	Shank size [mm]:	40.00
	Shank type:	BMT
	Machine adaption:	Centering key slot b 12
	Tool adaption:	Sq. 25
		Sq. 25
		Sq. 25
		Sq. 25
	Coolant:	EXT
8 259 04 005	Multiple turning holder 4x sq.20/ 3/4"	
	Weight [kg]:	7.000
	Employment for:	Main- and sub spindle
	Version:	Y-axes offset
	Shank type:	BMT
	Machine adaption:	Centering key slot b 12
	Tool adaption:	Sq. 20/3/4" (19,05mm)
		Sq. 20/3/4" (19,05mm)
		Sq. 20/3/4" (19,05mm)

Part-#	Name	
	Coolant:	Sq. 20/3/4" (19,05mm) EXT
8 320 02 023	Cut-off holder, height adjustable SH 26 IC	
	Weight [kg]:	2.030
	Notation:	180° reversible
	Shank type:	BMT
	Machine adaption:	Centering key slot b 12
	Tool adaption:	Clampshaft SH 26
	Coolant:	IC/Ext
	Pressure max [bar]:	70
8 320 03 033	Cut-off holder, height adjustable SH 32 IC	
	Weight [kg]:	2.290
	Notation:	180° reversible
	Shank type:	BMT
	Machine adaption:	Centering key slot b 12
	Tool adaption:	Clampshaft SH 32
	Coolant:	IC/Ext
	Pressure max [bar]:	70
	Please note:	Clampshaft internal
8 320 09 006	Cut-off holder, height adjustable 845 IC	
	Notation:	180° reversible
	Shank type:	BMT
	Machine adaption:	Centering key slot b 12
	Tool adaption:	 System 845
	Coolant:	IC
	Pressure max [bar]:	70

heimatec.u-tec®

heimatec.com

Products / Tool change systems /
u-tec® Tool-changing system



versions see catalog

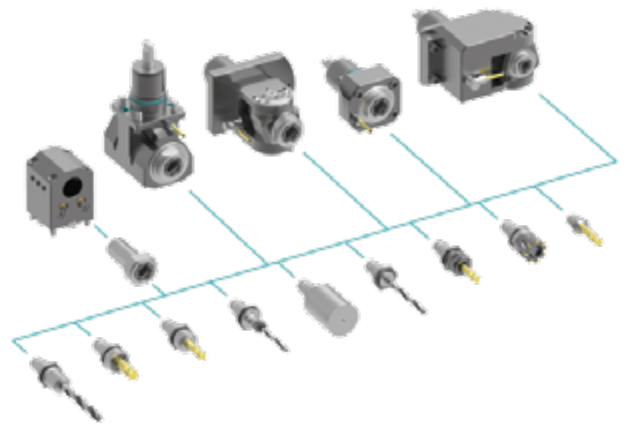

heimatec.easy-quick

heimatec.com

Products / Tool change systems /
easy-quick HT quick-changing system



versions see catalog

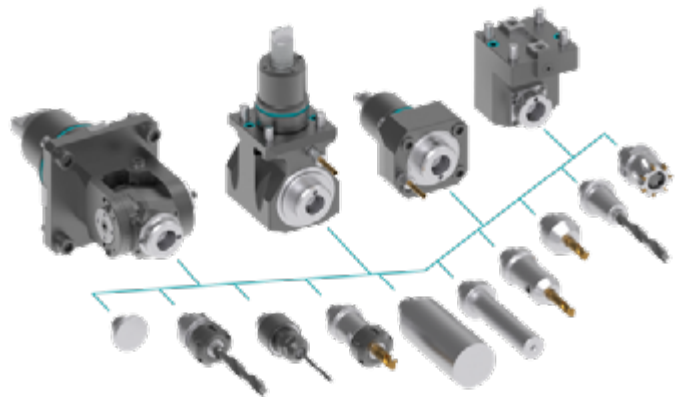

heimatec.Capto™

heimatec.com

Products / Tool change systems /
heimatec.Capto™ quick-changing system



versions see catalog

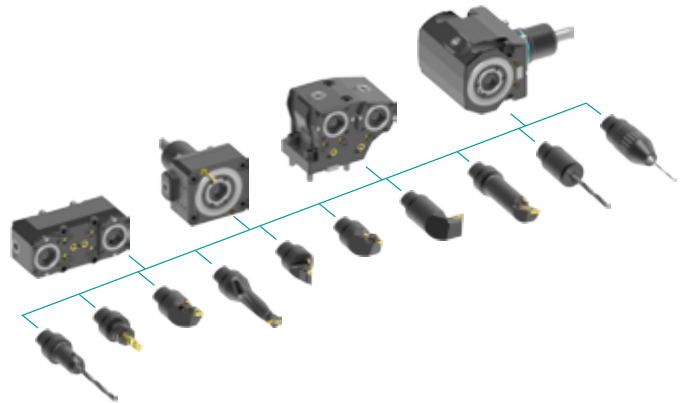

heimatec.accessories

heimatec.com

Products / Accessories



versions see catalog





● heimatec overseas branches

○ global representations of heimatec

heimatec[®]

heimatec GmbH
Präzisionswerkzeuge
Carl-Benz-Str. 4
77871 Renchen
Germany

T +49 7843 9466 0
www.heimatec.com
info@heimatec.com

Please find the contact details of our worldwide trading partners on our website:
<https://heimatec.com/business-partners>