

機械加工中心用--
高精密角度頭

„標準“系列
尺寸3

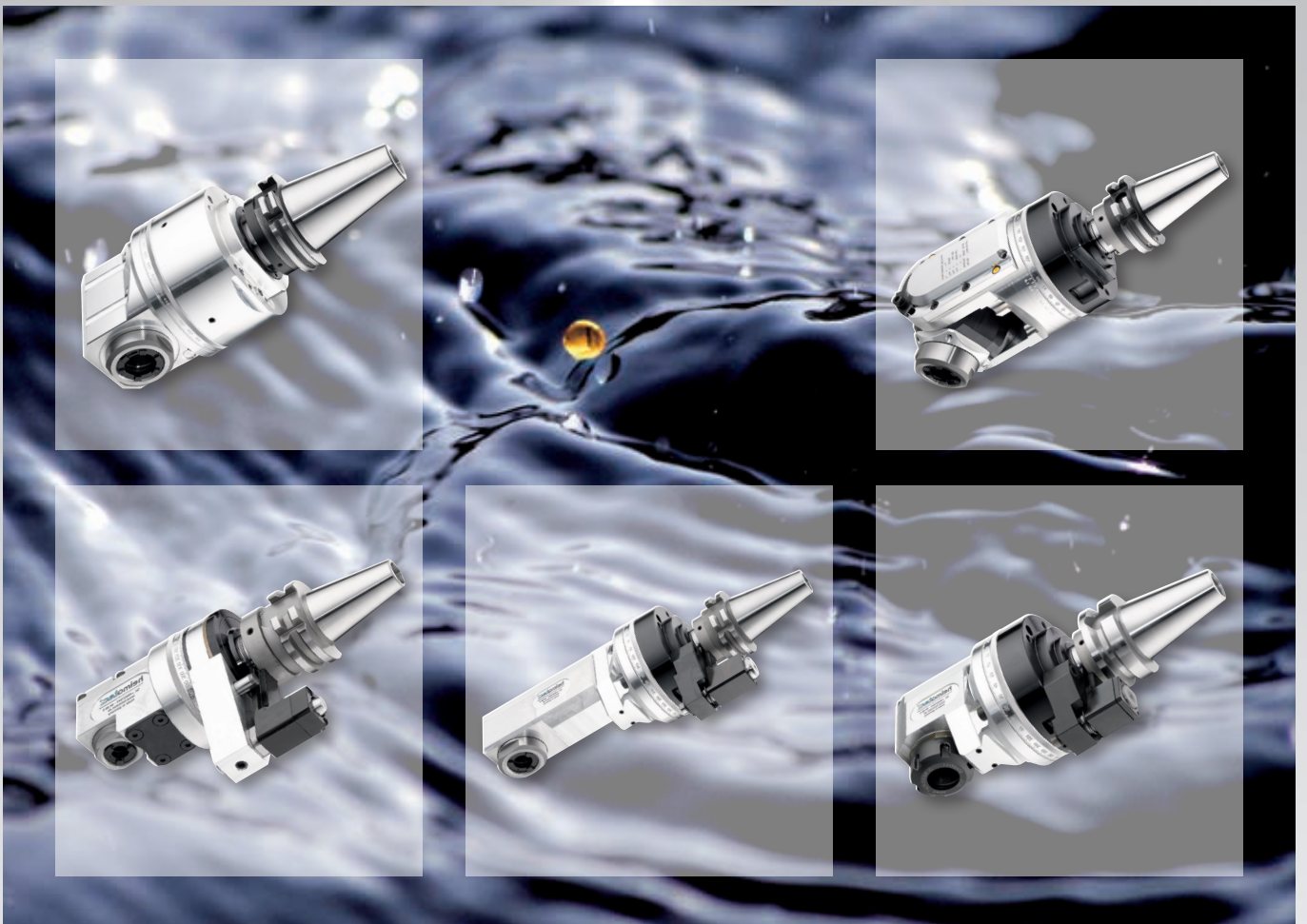



歡迎參觀官網：
www.heimatec.com
首頁/版權/條款

本目錄，包含所有零配件，皆受版權保護
任何資料與版權必須於heimatec授權同意後才可使用 尤其是複製、翻譯、影片…等 以電子產品裝置呈現。

heimatec® GmbH 在因應國際法規標準的更變與頒布，或關於公司產品的研發、生產、製程…等。在無需事先通知下，我們保有隨時更改內容的權力。

▶ 角度頭 系列 „標準“
適應各種應用



▶ 角度頭；標準
可旋轉360°
用於較彈性加工

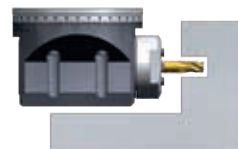

▶ 角度頭；雙軸
可旋轉360°
用於較彈性且雙向的加工



▶ 角度頭；標準；偏擺
可旋轉360°
用於較彈性加工，偏擺刀座大幅增加可用刀具長度。

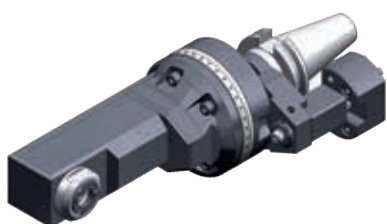
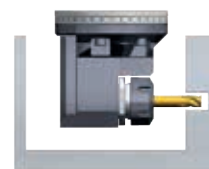

▶ 角度頭；偏擺；精細型
可旋轉360°
用於較小的加工環境/工件，偏擺刀座大幅增加可用刀具長度。

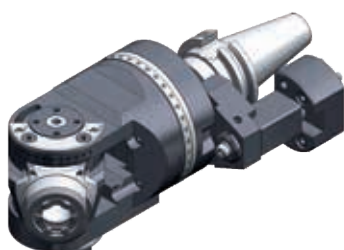

▶ 角度頭；約 ± 90° 度可調整式
可旋轉360°
用於較彈性加工並可任意變換加銑加工方向以及角度。



► 我們的設計

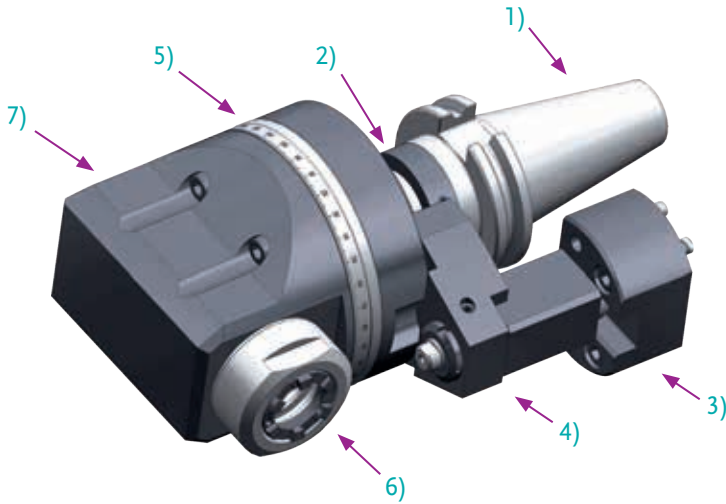

- 1) 刀座/機台連結介面
DIN 69871 A - SK
DIN 69893 - HSK
MAS 403 BT
ANSI B 5.50/ CAT
- 2) 定位環
刀座驅動鎖定
- 3) 止動塊
鎖定以及固定角度頭，使其無法任意旋轉。也可客製鎖定/固定方式
- 4) 支撐臂
將箱體固定於機台上，防止其任意轉動。
- 5) 定標環
刀座的可調式角度功能和不中斷的轉動，可確保最佳加工角度。
- 6) 連結介面
標準刀座皆標配筒夾
- 7) 箱體
可依加工需求調整或替換為45/90度

► 適用的組合

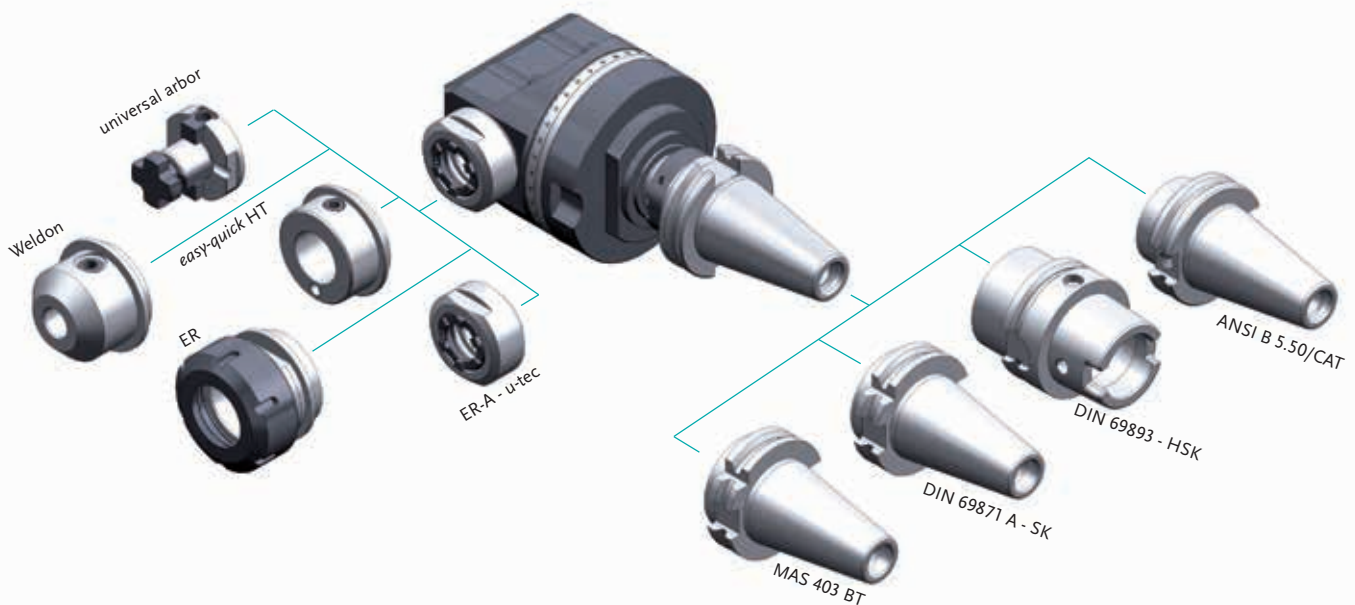

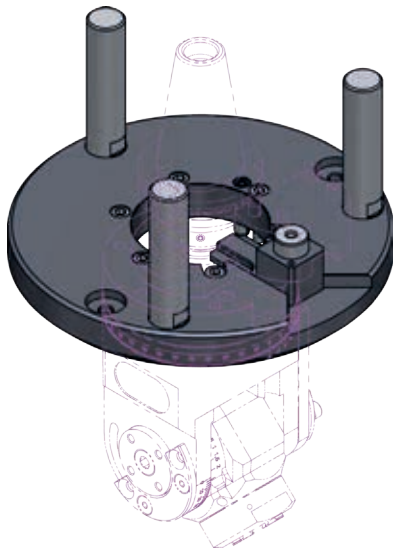

▶ 法蘭〈含內建支撐臂款〉

用於重加工，使其有更強更穩定的支撐力並且防止震動。此額外的支撐法蘭可依客戶需求以及機台的規格進行設計以及製作。

▶ 支撐臂

此配件用於支撐刀座於機台，以防止刀座旋轉或者晃動。可依客戶需求做額外的加工與設計。

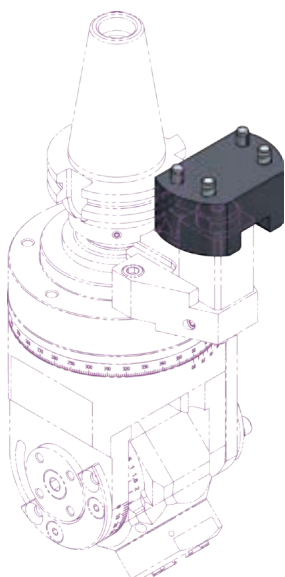
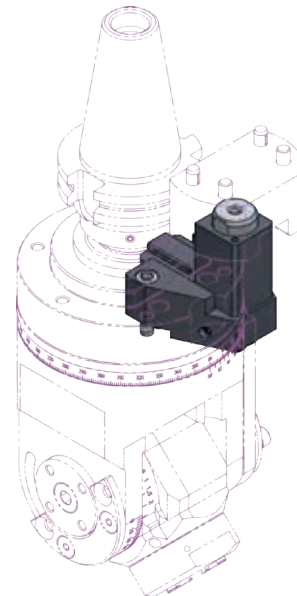

▶ 止動塊

用於鎖定以及固定刀座使其無法任意轉動。可依客戶需求做額外的加工與設計。

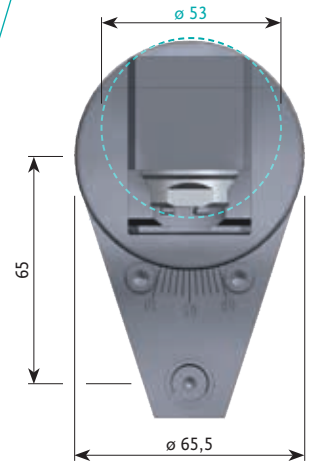
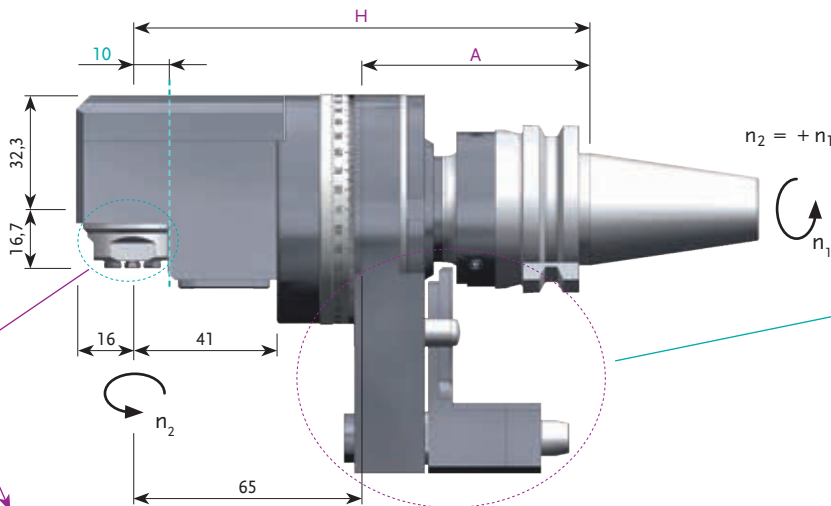
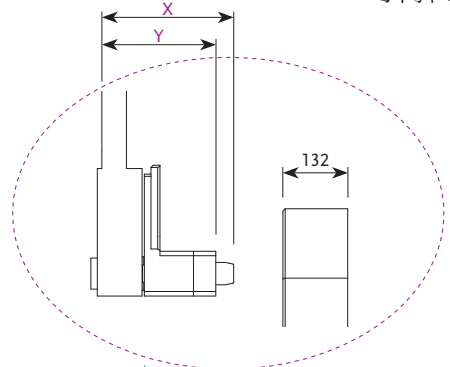
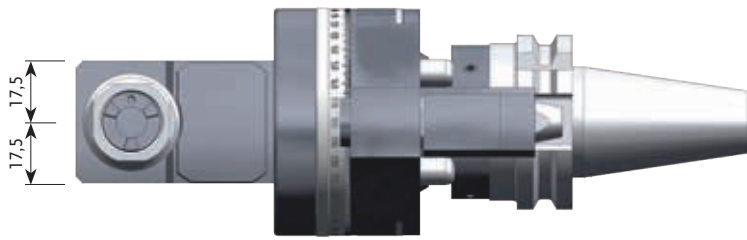

▶ 角度頭

360° 可轉向



刀具應用 : ER 11 A (ø0,5 - ø7,0)
 旋轉 $n_2 \text{ max}$ [1/min] : 8000
 扭力 $M_2 \text{ max}$ [Nm] : 6

冷卻劑 :-
 齒輪比 [i] : 1:1
 旋轉方向 : 相同

參考代碼	刀座/機台連結介面	中心軸距離 H [mm]	外殼/箱體規線 A [mm]	扳手		止動塊	
					參數 X [mm]		參數 Y [mm]
7 033 23 002	 DIN 69871 A - SK 30	130	65		59	51	
7 033 23 001					59	51	
7 033 23 000					-	-	
7 033 33 002	 DIN 69893 - HSK 40 A	138	73		59	51	
7 033 33 001					59	51	
7 033 33 000					-	-	
7 033 23 005	 MAS 403 BT 30	130	65		59	51	
7 033 23 004					59	51	
7 033 23 003					-	-	

可另加購支撐法蘭

x = 不包含在運送內
 ✓ = 包含在運送內
 參數 X = 底面固定螺栓/箱體基準線
 參數 Y = 固定器/箱體基準線

▶ 其他需求請另外詢問

▶ 角度頭

360° 可轉向

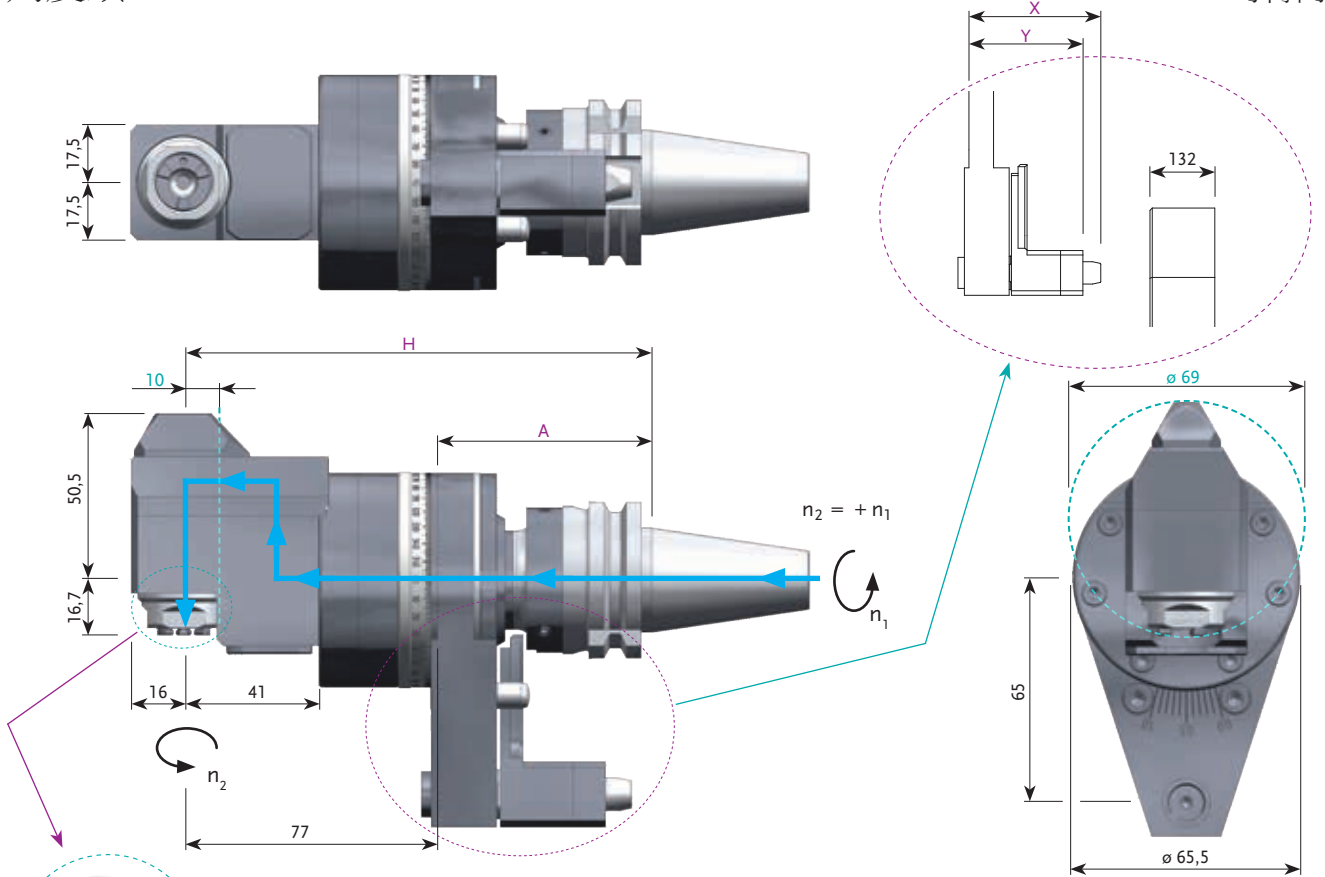

刀具應用：ER 11 A (ø0,5 - ø7,0)
 旋轉 $n_2 \text{ max}$ [1/min] : 8000
 扭力 $M_2 \text{ max}$ [Nm] : 6

← 冷卻劑：IK 70 [bar] —
 齒輪比 [i] : 1:1
 旋轉方向：相同

參考代碼	刀座/機台連結介面	中心軸距離 H [mm]	外殼/箱體規線 A [mm]	扳手			止動塊
					參數 X [mm]	參數 Y [mm]	
7 033 23 008	 DIN 69871 A - SK 30	142	65	✓	59	51	✓
7 033 23 007				✓	59	51	✗
7 033 23 006				✗	-	-	✗
7 033 33 005	 DIN 69893 - HSK 40 A	150	73	✓	59	51	✓
7 033 33 004				✓	59	51	✗
7 033 33 003				✗	-	-	✗
7 033 23 011	 MAS 403 BT 30	142	65	✓	59	51	✓
7 033 23 010				✓	59	51	✗
7 033 23 009				✗	-	-	✗

可另加購支撐法蘭

✗ = 不包含在運送內
 ✓ = 包含在運送內
 參數 X = 底面固定螺栓/箱體基準線
 參數 Y = 固定器/箱體基準線

▶ 其他需求請另外詢問

▶ 角度頭 + 90°

360° 可轉向

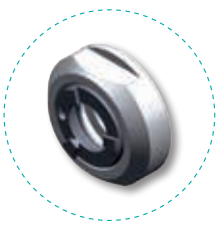
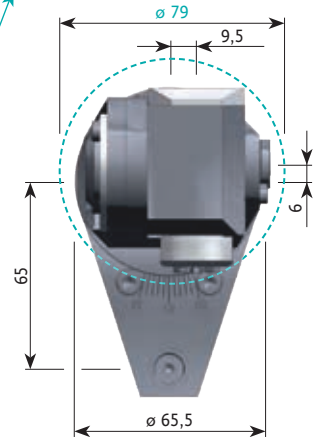
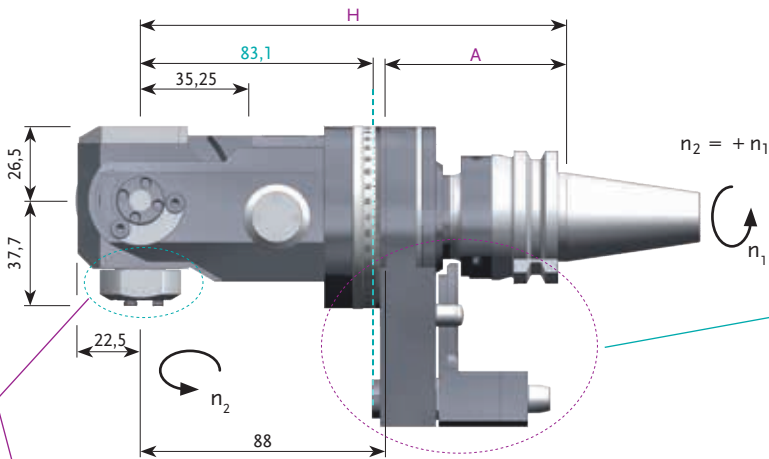
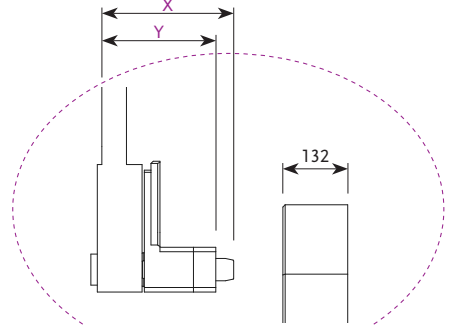

刀具應用：ER 11 A (ø0,5 - ø7,0)
 旋轉 $n_2 \text{ max}$ [1/min] : 8000
 扭力 $M_2 \text{ max}$ [Nm] : 5

冷卻劑：-
 齒輪比 [i] : 1:1
 旋轉方向：相同

參考代碼	刀座/機台連結介面	中心軸距離 H [mm]	外殼/箱體規線 A [mm]	扳手			止動塊
					參數 X [mm]	參數 Y [mm]	
7 043 23 008		153	65	✓	59	51	✓
7 043 23 007				✓	59	51	✗
7 043 23 006				✗	-	-	✗
7 043 33 002		161	73	✓	59	51	✓
7 043 33 001				✓	59	51	✗
7 043 33 000				✗	-	-	✗
7 043 23 003		153	65	✓	59	51	✓
7 043 23 000				✓	59	51	✗
7 043 23 002				✗	-	-	✗

可另加購支撐法蘭

✗ = 不包含在運送內
 ✓ = 包含在運送內
 參數 X = 底面固定螺栓/箱體基準線
 參數 Y = 固定器/箱體基準線

▶ 其他需求請另外詢問

▶ 角度頭 + 90°

360° 可轉向

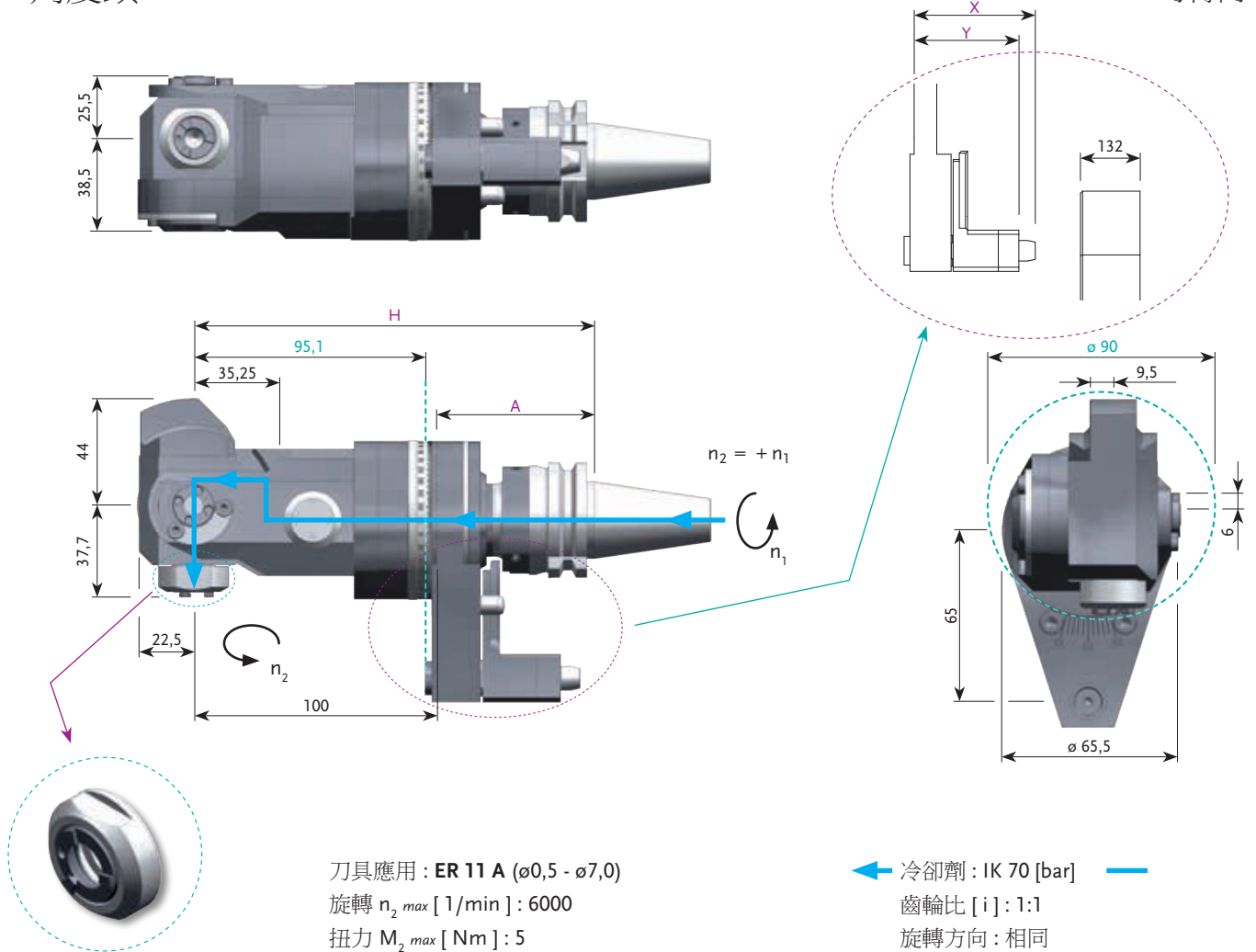

尺寸 3

參考代碼	刀座/機台連結介面	中心軸距離 H [mm]	外殼/箱體規線 A [mm]	扳手		止動塊	
				參數 X [mm]	參數 Y [mm]		
7 043 23 011	 DIN 69871 A - SK 30	165	65	✓	59	51	✓
7 043 23 010				✓	59	51	✗
7 043 23 009				✗	-	-	✗
7 043 33 005	 DIN 69893 - HSK 40 A	173	73	✓	59	51	✓
7 043 33 004				✓	59	51	✗
7 043 33 003				✗	-	-	✗
7 043 23 005	 MAS 403 BT 30	165	65	✓	59	51	✓
7 043 23 001				✓	59	51	✗
7 043 23 004				✗	-	-	✗

可另加購支撐法蘭

✗ = 不包含在運送內
 ✓ = 包含在運送內
 參數 X = 底面固定螺栓/箱體基準線
 參數 Y = 固定器/箱體基準線

▶ 其他需求請另外詢問

7 040 45 007
角度頭
± 90° 可調整式
ER 25 AX - u-tec



7 033 45 021
角度頭
偏擺
ER 25



7 037 86 000
盤銑頭
刀把 27



7 033 23 001
角度頭
偏擺
ER 11 A



7 039 64 000
銑削角度頭
雙軸
刀把 16



7 030 66 010
角度頭
ER 32 AX - u-tec



7 050 54 003
多軸鑽削刀座
6 - 軸
ER 16 M



7 030 41 064
角度頭
RA - 100
CH8



7 039 41 017
角度頭
KC - 300
CHC



7 030 41 061
角度頭
MFC - 300 S
K252



► easy-quick HT 快換系統

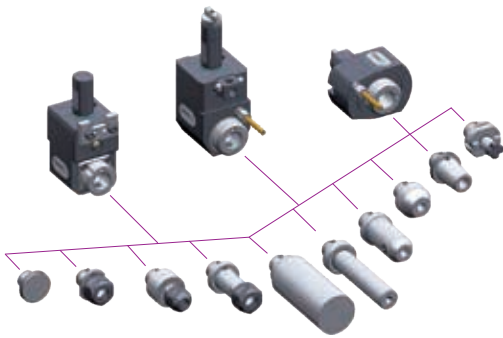

Heimatec 快換系統，適用於標準/動力刀座

► 更多的產品請詳見heimatec目錄



www.heimatec.com
HT快換系統

► u-tec 快換系統

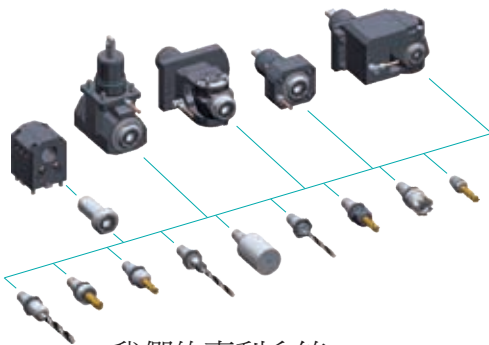

我們的專利系統，
使刀具的更換有無限可能！

► 更多的產品請詳見heimatec目錄



www.heimatec.com
u-tec

► 配件



► 更多的產品請詳見heimatec目錄



www.heimatec.com
其他配件

heimatec®

● heimatec® - 海外分公司與辦事處

● heimatec® - 全球代理商

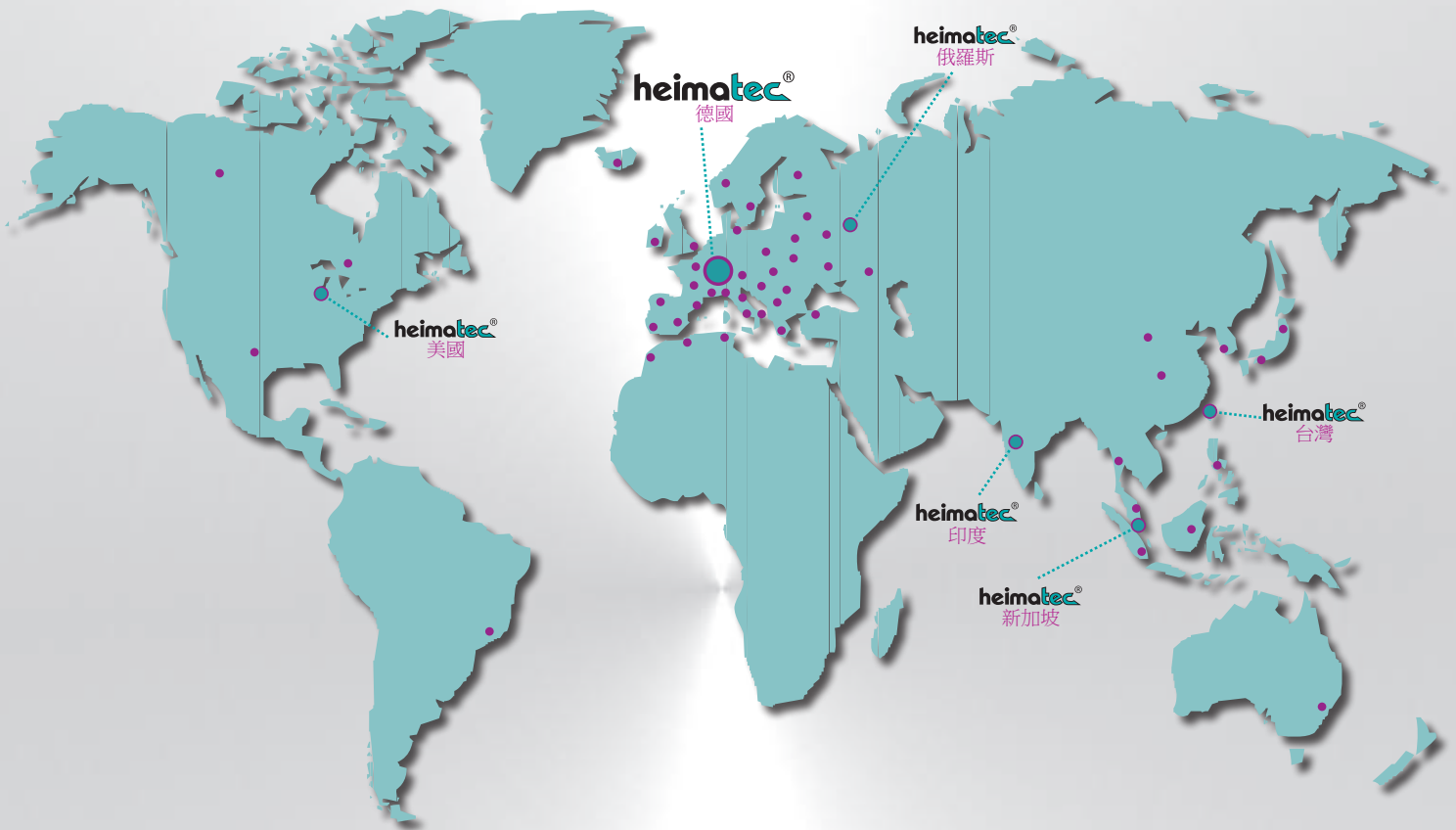

德國總部

heimatec® GmbH
Präzisionswerkzeuge
Carl-Benz-Straße 4
D- 77871 Renchen
Postfach 11 36
D- 77867 Renchen
Tel.: +49 (78 43) 94 66 0
Fax: +49 (78 43) 94 66 66
heimatec.de
info@heimatec.de

heimatec® Inc.
USA
usa.heimatec.com
USA@heimatec.com

heimatec®-Ost, JSC
Russia
ru.heimatec.com
Russia@heimatec.com

大中華區銷售總部

heimatec® Ltd.
Taiwan
tw.heimatec.com
Taiwan@heimatec.com

heimatec®
Singapore
sg.heimatec.com
Singapore@heimatec.com

heimatec® India Pvt Ltd.
India
in.heimatec.com
India@heimatec.com

