

Gildemeister

Twin 65 - VDI 40



High-tech from heimatec - heimatec - Tools and systems for productive turning and milling

heimatec belongs to the international technology and quality leaders for precision tools and specializes in the development and production of high-precision static and live tools for all CNC lathes, CNC turn-/mill machines and CNC machining centers.

The range of products* spans from static BMT and VDI tool holders, live tools up to highly complex customer-specific individual solutions. heimatec, headquartered in Renchen, has a own subsidiary in Asia and India and numerous representatives as well as trading partners all over the world.

*OUR PRODCUTS

Static tool holders

Live tool units

Precision tools

Tools for turning and machining centres

Tools for swiss type lathes

Tool changing and uick-change systems

Tool systems for gear production

Digital tool management

This catalogue, including all its parts, is protected by copyright. Any use outside the restricted limitations of the Copyright Act without the consent of heimatec is inadmissible and liable to prosecution. This applies in particular to duplication, translation, microfilming and storage and processing in electronic systems.

heimatec GmbH reserves the right to make technical changes at any time without giving prior notice. This applies in particular to adjustments at any time to meet new or changed international standards, or in case of further developments of our products or manufacturing processes.

The current version of our General Terms and Conditions can be found on our website.

Part-#	Name
--------	------

8 010 45 053	Axial drilling and milling head ER 25 IC
Weight [kg]:	3.420
Tool drive:	DIN 5480
Shank size [mm]:	40.00
Shank type:	VDI
Tool adaption:	ER 25
Gear ratio [i]:	1:1
Torque max [Nm]:	50
Rotation max [1/min]:	6000
Rotating direction:	same
Coolant:	IC/Ext
Pressure max [bar]:	25
Please note:	round housing ø 84

8 010 45 094	Axial drilling and milling head ER 25 AX UT
Weight [kg]:	3.440
Tool drive:	DIN 5480
Shank size [mm]:	40.00
Shank type:	VDI
Tool adaption:	ER 25 A - u-tec
Gear ratio [i]:	1:1
Torque max [Nm]:	50
Rotation max [1/min]:	6000
Rotating direction:	same
Coolant:	EXT

8 010 45 156	Axial drilling and milling head ER 25 AX UT IC
Weight [kg]:	3.410
Tool drive:	DIN 5480
Shank size [mm]:	40.00
Shank type:	VDI
Tool adaption:	ER 25 A - u-tec
Gear ratio [i]:	1:1
Torque max [Nm]:	50
Rotation max [1/min]:	6000
Rotating direction:	same
Coolant:	IC/Ext
Pressure max [bar]:	25



8 010 46 152	Axial drilling and milling head ER 32 AX UT
Weight [kg]:	3.270
Tool drive:	DIN 5480
Shank size [mm]:	40.00
Shank type:	VDI
Tool adaption:	ER 32 A - u-tec
Gear ratio [i]:	1:1
Torque max [Nm]:	50
Rotation max [1/min]:	6000
Rotating direction:	same
Coolant:	EXT

Part-#	Name
8 010 46 165	Axial drilling and milling head ER 32 AX UT IC
	Weight [kg]: 3.440
	Tool drive: DIN 5480
	Shank size [mm]: 40.00
	Shank type: VDI
	Tool adaption: ER 32 A - u-tec
	Gear ratio [i]: 1:1
	Torque max [Nm]: 50
	Rotation max [1/min]: 6000
	Rotating direction: same
	Coolant: IC/Ext
	Pressure max [bar]: 25
8 010 46 235	Axial drilling and milling head ER 32 AX UT IC
	Tool drive: DIN 5480
	Shank size [mm]: 40.00
	Shank type: VDI
	Tool adaption: ER 32 A - u-tec
	Gear ratio [i]: 1:1
	Torque max [Nm]: 50
	Rotation max [1/min]: 10000
	Rotating direction: same
	Coolant: IC/Ext
	Pressure max [bar]: 100
	Please note: Dryrun possible
8 010 46 304	Axial drilling and milling head C 4
	Weight [kg]: 4.330
	Version: right
	Tool drive: DIN 5480
	Shank size [mm]: 40.00
	Shank type: VDI
	Tool adaption: heimatec Capto(TM) C 4
	Gear ratio [i]: 1:1
	Torque max [Nm]: 50
	Rotation max [1/min]: 6000
	Rotating direction: same
	Coolant: EXT
	Please note: stronger bearing
8 010 47 034	Axial drilling and milling head HT 5
	Weight [kg]: 3.300
	Tool drive: DIN 5480
	Shank size [mm]: 40.00
	Shank type: VDI
	Tool adaption: HT 5
	Gear ratio [i]: 1:1
	Torque max [Nm]: 50
	Rotation max [1/min]: 6000
	Rotating direction: same
	Coolant: EXT
	Please note: round housing Ø 84

Part-#	Name	
8 010 47 086	Axial drilling and milling head HT 5	
	Weight [kg]:	3.330
	Tool drive:	DIN 5480
	Shank size [mm]:	40.00
	Shank type:	VDI
	Tool adaption:	HT 5
	Gear ratio [i]:	1:1
	Torque max [Nm]:	50
	Rotation max [1/min]:	4000
	Rotating direction:	same
	Coolant:	EXT
	Please note:	Combi bearing
8 010 48 001	Axial drilling and milling head HT 6 IC	
	Weight [kg]:	4.220
	Tool drive:	DIN 5480
	Shank size [mm]:	40.00
	Shank type:	VDI
	Tool adaption:	HT 6
	Gear ratio [i]:	1:1
	Torque max [Nm]:	50
	Rotation max [1/min]:	6000
	Rotating direction:	same
	Coolant:	IC/Ext
	Pressure max [bar]:	25
	Please note:	round housing ø 84
8 013 44 005	Axial drilling and milling head ER 16 AX UT	
	Weight [kg]:	2.940
	Tool drive:	DIN 5480
	Shank size [mm]:	40.00
	Shank type:	VDI
	Tool adaption:	ER 16 A - u-tec
	Gear ratio [i]:	1:4
	Torque max [Nm]:	5
	Rotation max [1/min]:	24000
	Rotating direction:	same
	Coolant:	EXT
8 030 45 085	Radial drilling and milling head ER 25	
	Weight [kg]:	6.560
	Version:	right
	Tool drive:	DIN 5480
	Shank size [mm]:	40.00
	Shank type:	VDI
	Tool adaption:	ER 25
	Gear ratio [i]:	1:1
	Torque max [Nm]:	50
	Rotation max [1/min]:	6000
	Rotating direction:	opposite
	Coolant:	EXT
	Center distance [mm]:	100

Part-#	Name	
8 030 45 090	Radial drilling and milling head ER 25	
	Version:	left
	Tool drive:	DIN 5480
	Shank size [mm]:	40.00
	Shank type:	VDI
	Tool adaption:	ER 25
	Gear ratio [i]:	1:1
	Torque max [Nm]:	50
	Rotation max [1/min]:	6000
	Rotating direction:	opposite
	Coolant:	EXT
	Center distance [mm]:	100
8 030 45 223	Radial drilling and milling head ER 25 AX UT	
	Weight [kg]:	6.520
	Version:	right
	Tool drive:	DIN 5480
	Shank size [mm]:	40.00
	Shank type:	VDI
	Tool adaption:	ER 25 A - u-tec
	Gear ratio [i]:	1:1
	Torque max [Nm]:	50
	Rotation max [1/min]:	6000
	Rotating direction:	opposite
	Coolant:	EXT
	Center distance [mm]:	100
8 030 46 113	Radial drilling and milling head ER 32	
	Weight [kg]:	7.500
	Version:	left
	Tool drive:	DIN 5480
	Shank size [mm]:	40.00
	Shank type:	VDI
	Tool adaption:	ER 32
	Gear ratio [i]:	1:1
	Torque max [Nm]:	50
	Rotation max [1/min]:	6000
	Rotating direction:	opposite
	Coolant:	EXT
	Please note:	with fixation pin
	Center distance [mm]:	120
8 030 46 119	Radial drilling and milling head ER 32	
	Weight [kg]:	6.630
	Version:	left
	Tool drive:	DIN 5480
	Shank size [mm]:	40.00
	Shank type:	VDI
	Tool adaption:	ER 32
	Gear ratio [i]:	1:1
	Torque max [Nm]:	50
	Rotation max [1/min]:	6000
	Rotating direction:	opposite
	Coolant:	EXT
	Center distance [mm]:	100

Part-#	Name	
8 030 46 120	Radial drilling and milling head ER 32 IC	
	Weight [kg]:	7.990
	Version:	left
	Tool drive:	DIN 5480
	Shank size [mm]:	40.00
	Shank type:	VDI
	Tool adaption:	ER 32
	Gear ratio [i]:	1:1
	Torque max [Nm]:	50
	Rotation max [1/min]:	6000
	Rotating direction:	opposite
	Coolant:	IC/Ext
	Pressure max [bar]:	140
	Center distance [mm]:	120
8 030 46 141	Radial drilling and milling head ER 32	
	Weight [kg]:	7.480
	Version:	left
	Tool drive:	DIN 5480
	Shank size [mm]:	40.00
	Shank type:	VDI
	Tool adaption:	ER 32
	Gear ratio [i]:	2:1
	Torque max [Nm]:	63
	Rotation max [1/min]:	3000
	Rotating direction:	opposite
	Coolant:	EXT
	Please note:	with fixation pin
	Center distance [mm]:	120
8 030 46 170	Radial drilling and milling head ER 32 IC	
	Version:	left
	Tool drive:	DIN 5480
	Shank size [mm]:	40.00
	Shank type:	VDI
	Tool adaption:	ER 32
	Gear ratio [i]:	1:1
	Torque max [Nm]:	50
	Rotation max [1/min]:	6000
	Rotating direction:	opposite
	Coolant:	IC/Ext
	Pressure max [bar]:	140
	Please note:	with fixation pin
	Center distance [mm]:	100
8 030 46 249	Radial drilling and milling head ER 32	
	Weight [kg]:	6.820
	Version:	left
	Tool drive:	DIN 5480
	Shank size [mm]:	40.00
	Shank type:	VDI
	Tool adaption:	ER 32
	Gear ratio [i]:	1:1
	Torque max [Nm]:	50
	Rotation max [1/min]:	6000
	Rotating direction:	same
	Coolant:	EXT
	Center distance [mm]:	100

Part-#	Name
8 030 46 251	Radial drilling and milling head ER 32 IC
	Weight [kg]: 7.540
	Version: left
	Tool drive: DIN 5480
	Shank size [mm]: 40.00
	Shank type: VDI
	Tool adaption: ER 32
	Gear ratio [i]: 1:1
	Torque max [Nm]: 50
	Rotation max [1/min]: 6000
	Rotating direction: same
	Coolant: IC/Ext
	Pressure max [bar]: 25
	Center distance [mm]: 100
8 030 46 304	Radial drilling and milling head ER 32 AX UT IC
	Version: left
	Tool drive: DIN 5480
	Shank size [mm]: 40.00
	Shank type: VDI
	Tool adaption: ER 32 A - u-tec
	Gear ratio [i]: 1:1
	Torque max [Nm]: 50
	Rotation max [1/min]: 6000
	Rotating direction: opposite
	Coolant: IC/Ext
	Pressure max [bar]: 140
	Center distance [mm]: 100
8 030 46 306	Radial drilling and milling head ER 32 AX UT
	Weight [kg]: 6.390
	Version: left
	Tool drive: DIN 5480
	Shank size [mm]: 40.00
	Shank type: VDI
	Tool adaption: ER 32 A - u-tec
	Gear ratio [i]: 1:1
	Torque max [Nm]: 50
	Rotation max [1/min]: 6000
	Rotating direction: opposite
	Coolant: EXT
	Center distance [mm]: 100
8 030 46 307	Radial drilling and milling head ER 32 AX UT
	Weight [kg]: 6.310
	Version: right
	Tool drive: DIN 5480
	Shank size [mm]: 40.00
	Shank type: VDI
	Tool adaption: ER 32 A - u-tec
	Gear ratio [i]: 1:1
	Torque max [Nm]: 50
	Rotation max [1/min]: 6000
	Rotating direction: opposite
	Coolant: EXT
	Center distance [mm]: 100

Part-#	Name	
8 030 46 317	Radial drilling and milling head ER 32 AX UT	
	Weight [kg]:	7.280
	Version:	right
	Tool drive:	DIN 5480
	Shank size [mm]:	40.00
	Shank type:	VDI
	Tool adaption:	ER 32 A - u-tec
	Gear ratio [i]:	1:1
	Torque max [Nm]:	50
	Rotation max [1/min]:	6000
	Rotating direction:	opposite
	Coolant:	EXT
	Center distance [mm]:	120
8 030 47 029	Radial drilling and milling head HT 5	
	Version:	left
	Tool drive:	DIN 5480
	Shank size [mm]:	40.00
	Shank type:	VDI
	Tool adaption:	HT 5
	Gear ratio [i]:	1:1
	Torque max [Nm]:	50
	Rotation max [1/min]:	6000
	Rotating direction:	opposite
	Coolant:	EXT
	Please note:	stronger bearing
	Center distance [mm]:	120
8 030 47 067	Radial drilling and milling head HT 5	
	Weight [kg]:	5.560
	Version:	left
	Tool drive:	DIN 5480
	Shank size [mm]:	40.00
	Shank type:	VDI
	Tool adaption:	HT 5
	Gear ratio [i]:	1:1
	Torque max [Nm]:	50
	Rotation max [1/min]:	6000
	Rotating direction:	opposite
	Coolant:	EXT
	Center distance [mm]:	100
8 030 47 078	Radial drilling and milling head Weldon 25	
	Weight [kg]:	7.640
	Version:	left
	Tool drive:	DIN 5480
	Shank size [mm]:	40.00
	Shank type:	VDI
	Tool adaption:	Weldon (DIN 1835 b) 25
	Gear ratio [i]:	1:1
	Torque max [Nm]:	50
	Rotation max [1/min]:	6000
	Rotating direction:	opposite
	Coolant:	EXT
	Please note:	stronger bearing
	Center distance [mm]:	100

Part-#	Name	
8 030 47 142	Radial drilling and milling head HT 5 IC	
	Weight [kg]:	8.290
	Version:	right
	Tool drive:	DIN 5480
	Shank size [mm]:	40.00
	Shank type:	VDI
	Tool adaption:	HT 5
	Gear ratio [i]:	1:2
	Torque max [Nm]:	16
	Rotation max [1/min]:	12000
	Rotating direction:	opposite
	Coolant:	IC/Ext
	Pressure max [bar]:	140
	Please note:	stronger bearing
	Center distance [mm]:	100
8 030 48 004	Radial drilling and milling head HT 6 IC	
	Version:	left
	Tool drive:	DIN 5480
	Shank size [mm]:	40.00
	Shank type:	VDI
	Tool adaption:	HT 6
	Gear ratio [i]:	2:1
	Torque max [Nm]:	63
	Rotation max [1/min]:	4000
	Rotating direction:	opposite
	Coolant:	IC/Ext
	Pressure max [bar]:	25
	Please note:	stronger bearing
	Center distance [mm]:	120
8 030 48 005	Radial drilling and milling head HT 6 IC	
	Version:	left
	Tool drive:	DIN 5480
	Shank size [mm]:	40.00
	Shank type:	VDI
	Tool adaption:	HT 6
	Gear ratio [i]:	1:2
	Torque max [Nm]:	16
	Rotation max [1/min]:	8000
	Rotating direction:	opposite
	Coolant:	IC/Ext
	Please note:	stronger bearing
	Center distance [mm]:	120
8 030 48 006	Radial drilling and milling head HT 6 IC	
	Weight [kg]:	7.900
	Version:	left
	Tool drive:	DIN 5480
	Shank size [mm]:	40.00
	Shank type:	VDI
	Tool adaption:	HT 6
	Gear ratio [i]:	1:1
	Torque max [Nm]:	50
	Rotation max [1/min]:	6000
	Rotating direction:	opposite
	Coolant:	IC/Ext
	Pressure max [bar]:	140

Part-#	Name	
	Please note:	stronger bearing
	Center distance [mm]:	100
8 030 48 017	Radial drilling and milling head HT 6 IC	
	Version:	Special; left
	Tool drive:	DIN 5480
	Shank size [mm]:	40.00
	Shank type:	VDI
	Tool adaption:	HT 6
	Gear ratio [i]:	1:1
	Torque max [Nm]:	50
	Rotation max [1/min]:	6000
	Rotating direction:	opposite
	Coolant:	IC/Ext
	Pressure max [bar]:	25
	Please note:	stronger bearing
	Center distance [mm]:	120
8 031 44 025	Radial milling head universal arbor 16	
	Version:	left
	Tool drive:	DIN 5480
	Shank size [mm]:	40.00
	Shank type:	VDI
	Tool adaption:	Universal arbor 16
	Gear ratio [i]:	1:1
	Torque max [Nm]:	50
	Rotation max [1/min]:	6000
	Rotating direction:	opposite
	Coolant:	EXT
	Center distance [mm]:	100
8 031 45 019	Radial polygon head arbor 22	
	Weight [kg]:	7.330
	Version:	left
	Tool drive:	DIN 5480
	Shank size [mm]:	40.00
	Shank type:	VDI
	Tool adaption:	Polygon arbor 22
	Gear ratio [i]:	1:1
	Torque max [Nm]:	50
	Rotation max [1/min]:	6000
	Rotating direction:	opposite
	Coolant:	EXT
	Please note:	stronger bearing
	Center distance [mm]:	100
8 031 46 009	Radial milling head universal arbor 27	
	Version:	left
	Tool drive:	DIN 5480
	Shank size [mm]:	40.00
	Shank type:	VDI
	Tool adaption:	Universal arbor 27
	Gear ratio [i]:	2:1
	Torque max [Nm]:	63
	Rotation max [1/min]:	3000
	Rotating direction:	opposite
	Coolant:	EXT
	Please note:	Combi bearing

Part-#	Name	
	Center distance [mm]:	100
8 033 46 115	Radial drilling and milling head ER 32 AX UT	
	Weight [kg]:	7.630
	Notation:	offset
	Version:	right
	Tool drive:	DIN 5480
	Shank size [mm]:	40.00
	Shank type:	VDI
	Tool adaption:	ER 32 A - u-tec
	Gear ratio [i]:	1:1
	Torque max [Nm]:	50
	Rotation max [1/min]:	6000
	Rotating direction:	same
	Coolant:	EXT
	Center distance [mm]:	100
8 033 47 013	Radial drilling and milling head HT 5 IC	
	Weight [kg]:	8.480
	Notation:	offset
	Version:	right
	Tool drive:	DIN 5480
	Shank size [mm]:	40.00
	Shank type:	VDI
	Tool adaption:	HT 5
	Gear ratio [i]:	1:1
	Torque max [Nm]:	50
	Rotation max [1/min]:	6000
	Rotating direction:	same
	Coolant:	IC/Ext
	Pressure max [bar]:	140
	Center distance [mm]:	100
8 033 47 023	Radial drilling and milling head HT 5	
	Weight [kg]:	8.960
	Notation:	offset
	Version:	left
	Tool drive:	DIN 5480
	Shank size [mm]:	40.00
	Shank type:	VDI
	Tool adaption:	HT 5
	Gear ratio [i]:	1:1
	Torque max [Nm]:	50
	Rotation max [1/min]:	6000
	Rotating direction:	same
	Coolant:	EXT
	Center distance [mm]:	120
8 033 47 030	Radial drilling and milling head HT 5 IC	
	Weight [kg]:	9.540
	Notation:	offset
	Version:	left
	Tool drive:	DIN 5480
	Shank size [mm]:	40.00
	Shank type:	VDI
	Tool adaption:	HT 5
	Gear ratio [i]:	1:1
	Torque max [Nm]:	50

Part-#	Name	
	Rotation max [1/min]:	6000
	Rotating direction:	same
	Coolant:	IC/Ext
	Pressure max [bar]:	140
	Center distance [mm]:	120
8 033 48 003	Radial drilling and milling head HT 6 IC	
	Weight [kg]:	8.940
	Notation:	offset
	Version:	right
	Tool drive:	DIN 5480
	Shank size [mm]:	40.00
	Shank type:	VDI
	Tool adaption:	HT 6
	Gear ratio [i]:	1:1
	Torque max [Nm]:	50
	Rotation max [1/min]:	6000
	Rotating direction:	same
	Coolant:	IC/Ext
	Pressure max [bar]:	140
	Please note:	stronger bearing
	Center distance [mm]:	100
8 033 48 004	Radial drilling and milling head HT 6 IC	
	Weight [kg]:	10.290
	Notation:	offset
	Version:	left
	Tool drive:	DIN 5480
	Shank size [mm]:	40.00
	Shank type:	VDI
	Tool adaption:	HT 6
	Gear ratio [i]:	1:1
	Torque max [Nm]:	50
	Rotation max [1/min]:	6000
	Rotating direction:	same
	Coolant:	IC/Ext
	Pressure max [bar]:	140
	Please note:	stronger bearing
	Center distance [mm]:	120
8 033 48 005	Radial drilling and milling head HT 6	
	Notation:	offset
	Version:	left
	Tool drive:	DIN 5480
	Shank size [mm]:	40.00
	Shank type:	VDI
	Tool adaption:	HT 6
	Gear ratio [i]:	1:1
	Torque max [Nm]:	50
	Rotation max [1/min]:	6000
	Rotating direction:	same
	Coolant:	EXT
	Please note:	stronger bearing
	Center distance [mm]:	120

Part-#	Name	
8 036 45 008	Radial drilling and milling head ER 25	
	Weight [kg]:	7.480
	Version:	doubletoothed
	Tool drive:	DIN 5480
	Shank size [mm]:	40.00
	Shank type:	VDI
	Tool adaption:	ER 25
	Gear ratio [i]:	1:1
	Torque max [Nm]:	50
	Rotation max [1/min]:	6000
	Rotating direction:	opposite
	Coolant:	EXT
	Center distance [mm]:	120
8 036 46 010	Radial drilling and milling head ER 32 AX UT	
	Weight [kg]:	6.490
	Version:	doubletoothed
	Tool drive:	DIN 5480
	Shank size [mm]:	40.00
	Shank type:	VDI
	Tool adaption:	ER 32 A - u-tec
	Gear ratio [i]:	1:1
	Torque max [Nm]:	50
	Rotation max [1/min]:	6000
	Rotating direction:	opposite
	Coolant:	EXT
	Center distance [mm]:	100
8 036 46 011	Radial drilling and milling head ER 32 AX UT IC	
	Weight [kg]:	7.870
	Version:	doubletoothed
	Tool drive:	DIN 5480
	Shank size [mm]:	40.00
	Shank type:	VDI
	Tool adaption:	ER 32 A - u-tec
	Gear ratio [i]:	1:1
	Torque max [Nm]:	50
	Rotation max [1/min]:	6000
	Rotating direction:	opposite
	Coolant:	IC/Ext
	Pressure max [bar]:	140
	Center distance [mm]:	120
8 036 46 012	Radial drilling and milling head ER 32 AX UT IC	
	Weight [kg]:	6.920
	Version:	doubletoothed
	Tool drive:	DIN 5480
	Shank size [mm]:	40.00
	Shank type:	VDI
	Tool adaption:	ER 32 A - u-tec
	Gear ratio [i]:	1:1
	Torque max [Nm]:	50
	Rotation max [1/min]:	6000
	Rotating direction:	opposite
	Coolant:	IC/Ext
	Pressure max [bar]:	140
	Center distance [mm]:	100

Part-#	Name	
8 036 46 014	Radial drilling and milling head ER 32 AX UT	
	Weight [kg]:	7.270
	Version:	doubletoothed
	Tool drive:	DIN 5480
	Shank size [mm]:	40.00
	Shank type:	VDI
	Tool adaption:	ER 32 A - u-tec
	Gear ratio [i]:	1:1
	Torque max [Nm]:	50
	Rotation max [1/min]:	6000
	Rotating direction:	opposite
	Coolant:	EXT
	Center distance [mm]:	120
8 039 45 031	Radial drilling and milling head ER 25 AX UT	
	Weight [kg]:	8.770
	Version:	double spindle
	Tool drive:	DIN 5480
	Shank size [mm]:	40.00
	Shank type:	VDI
	Tool adaption:	ER 25 A - u-tec
	Gear ratio [i]:	1:1
	Torque max [Nm]:	50
	Rotation max [1/min]:	6000
	Rotating direction:	same/opposite
	Coolant:	EXT
	Please note:	stronger bearing
	Center distance [mm]:	120
8 039 45 048	Radial drilling and milling head ER 25 AX UT	
	Weight [kg]:	7.940
	Version:	double spindle
	Tool drive:	DIN 5480
	Shank size [mm]:	40.00
	Shank type:	VDI
	Tool adaption:	ER 25 A - u-tec
	Gear ratio [i]:	1:1
	Torque max [Nm]:	50
	Rotation max [1/min]:	6000
	Rotating direction:	same/opposite
	Coolant:	EXT
	Please note:	stronger bearing
	Center distance [mm]:	100
8 039 46 016	Radial drilling and milling head ER 32	
	Version:	double spindle
	Tool drive:	DIN 5480
	Shank size [mm]:	40.00
	Shank type:	VDI
	Tool adaption:	ER 32
	Gear ratio [i]:	1:1
	Torque max [Nm]:	50
	Rotation max [1/min]:	6000
	Rotating direction:	same/opposite
	Coolant:	EXT
	Please note:	stronger bearing
	Center distance [mm]:	120

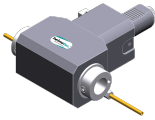
Part-#	Name	
8 039 46 056	Radial drilling and milling head ER 32 AX UT	
	Version:	double spindle
	Tool drive:	DIN 5480
	Shank size [mm]:	40.00
	Shank type:	VDI
	Tool adaption:	ER 32 A - u-tec
	Gear ratio [i]:	1:1
	Torque max [Nm]:	50
	Rotation max [1/min]:	6000
	Rotating direction:	same/opposite
	Coolant:	EXT
	Please note:	stronger bearing
	Center distance [mm]:	120
8 039 46 058	Radial drilling and milling head ER 32 AX UT	
	Weight [kg]:	8.640
	Version:	double spindle; doubletoothed
	Tool drive:	DIN 5480
	Shank size [mm]:	40.00
	Shank type:	VDI
	Tool adaption:	ER 32 A - u-tec
	Gear ratio [i]:	1:1
	Torque max [Nm]:	50
	Rotation max [1/min]:	6000
	Rotating direction:	same/opposite
	Coolant:	EXT
	Please note:	stronger bearing
	Center distance [mm]:	120
8 039 47 004	Radial drilling and milling head HT 5	
	Weight [kg]:	9.120
	Version:	double spindle
	Tool drive:	DIN 5480
	Shank size [mm]:	40.00
	Shank type:	VDI
	Tool adaption:	HT 5
	Gear ratio [i]:	1:1
	Torque max [Nm]:	50
	Rotation max [1/min]:	6000
	Rotating direction:	same/opposite
	Coolant:	EXT
	Please note:	stronger bearing
	Center distance [mm]:	120
8 040 44 066	Universal head ± 90° adjustable ER 16 AX UT	
	Version:	right
	Tool drive:	DIN 5480
	Shank size [mm]:	40.00
	Shank type:	VDI
	Tool adaption:	ER 16 A - u-tec
	Gear ratio [i]:	1:1
	Torque max [Nm]:	25
	Rotation max [1/min]:	6000
	Rotating direction:	opposite
	Coolant:	EXT
	Center distance [mm]:	87

Part-#	Name
8 040 44 067	Universal head ± 90° adjustable ER 16 AX UT
	Weight [kg]: 4.890
	Version: left
	Tool drive: DIN 5480
	Shank size [mm]: 40.00
	Shank type: VDI
	Tool adaption: ER 16 A - u-tec
	Gear ratio [i]: 1:1
	Torque max [Nm]: 25
	Rotation max [1/min]: 6000
	Rotating direction: opposite
	Coolant: EXT
	Center distance [mm]: 87
8 040 44 070	Universal head ± 90° adjustable ER 16 AX UT IC
	Version: right
	Tool drive: DIN 5480
	Shank size [mm]: 40.00
	Shank type: VDI
	Tool adaption: ER 16 A - u-tec
	Gear ratio [i]: 1:1
	Torque max [Nm]: 25
	Rotation max [1/min]: 6000
	Rotating direction: opposite
	Coolant: IC/Ext
	Pressure max [bar]: 140
	Center distance [mm]: 87
8 040 44 074	Universal head ± 90° adjustable ER 16 AX UT
	Version: left
	Tool drive: DIN 5480
	Shank size [mm]: 40.00
	Shank type: VDI
	Tool adaption: ER 16 A - u-tec
	Gear ratio [i]: 1:2
	Torque max [Nm]: 12
	Rotation max [1/min]: 12000
	Rotating direction: opposite
	Coolant: EXT
	Center distance [mm]: 87
8 040 44 078	Universal head ± 90° adjustable ER 16 AX UT IC
	Weight [kg]: 4.980
	Version: left
	Tool drive: DIN 5480
	Shank size [mm]: 40.00
	Shank type: VDI
	Tool adaption: ER 16 A - u-tec
	Gear ratio [i]: 1:2
	Torque max [Nm]: 12
	Rotation max [1/min]: 12000
	Rotating direction: opposite
	Coolant: IC/Ext
	Pressure max [bar]: 140
	Center distance [mm]: 87

Part-#	Name
8 040 45 073	Universal head ± 90° adjustable ER 25 AX UT IC
	<p>Version: left</p> <p>Tool drive: DIN 5480</p> <p>Shank size [mm]: 40.00</p> <p>Shank type: VDI</p> <p>Tool adaption: ER 25 A - u-tec</p> <p>Gear ratio [i]: 1:1</p> <p>Torque max [Nm]: 25</p> <p>Rotation max [1/min]: 6000</p> <p>Rotating direction: opposite</p> <p>Coolant: IC/Ext</p> <p>Pressure max [bar]: 140</p> <p>Please note: stronger bearing</p> <p>Center distance [mm]: 87</p>
8 040 45 093	Universal head ± 90° adjustable ER 25 AX UT
	<p>Weight [kg]: 5.160</p> <p>Version: right</p> <p>Tool drive: DIN 5480</p> <p>Shank size [mm]: 40.00</p> <p>Shank type: VDI</p> <p>Tool adaption: ER 25 A - u-tec</p> <p>Gear ratio [i]: 1:1</p> <p>Torque max [Nm]: 25</p> <p>Rotation max [1/min]: 6000</p> <p>Rotating direction: opposite</p> <p>Coolant: EXT</p> <p>Please note: stronger bearing</p> <p>Center distance [mm]: 87</p>
8 040 45 095	Universal head ± 90° adjustable ER 25 AX UT IC
	<p>Weight [kg]: 5.160</p> <p>Version: right</p> <p>Tool drive: DIN 5480</p> <p>Shank size [mm]: 40.00</p> <p>Shank type: VDI</p> <p>Tool adaption: ER 25 A - u-tec</p> <p>Gear ratio [i]: 1:1</p> <p>Torque max [Nm]: 25</p> <p>Rotation max [1/min]: 6000</p> <p>Rotating direction: opposite</p> <p>Coolant: IC/Ext</p> <p>Pressure max [bar]: 140</p> <p>Please note: stronger bearing</p> <p>Center distance [mm]: 87</p>
8 040 45 103	Universal head ± 90° adjustable ER 25 AX UT IC
	<p>Weight [kg]: 5.170</p> <p>Version: left; at 65° position can be pinned</p> <p>Tool drive: DIN 5480</p> <p>Shank size [mm]: 40.00</p> <p>Shank type: VDI</p> <p>Tool adaption: ER 25 A - u-tec</p> <p>Gear ratio [i]: 1:1</p> <p>Torque max [Nm]: 25</p> <p>Rotation max [1/min]: 6000</p> <p>Rotating direction: opposite</p> <p>Coolant: IC/Ext</p>

Part-#	Name	
	Pressure max [bar]:	140
	Please note:	stronger bearing
	Center distance [mm]:	87
8 040 45 139	Universal head ± 90° adjustable ER 25	
	Weight [kg]:	5.230
	Version:	left
	Tool drive:	DIN 5480
	Shank size [mm]:	40.00
	Shank type:	VDI
	Tool adaption:	ER 25
	Gear ratio [i]:	1:1
	Torque max [Nm]:	25
	Rotation max [1/min]:	6000
	Rotating direction:	opposite
	Coolant:	EXT
	Please note:	stronger bearing
	Center distance [mm]:	87
8 050 42 004	Multispindle drilling head ER 8	
	Weight [kg]:	4.780
	Notation:	offset
	Version:	2-spindles
	Tool drive:	DIN 5480
	Shank size [mm]:	40.00
	Shank type:	VDI
	Tool adaption:	ER 8
	Gear ratio [i]:	1:1
	Torque max [Nm]:	5/Sp.
	Rotation max [1/min]:	6000
	Rotating direction:	opposite
	Coolant:	EXT
	Please note:	Check applicability!
	Offset [mm]:	26,076
8 230 46 004	Boring bar holder Ø 20	
	Version:	right
	Shank size [mm]:	40.00
	Shank type:	VDI
	Tool adaption:	Ø 20
	Coolant:	IC/Ext
	Please note:	demountable in left version
	Center distance [mm]:	120
8 230 46 013	Collet chuck holder ER 32	
	Version:	right
	Shank size [mm]:	40.00
	Shank type:	VDI
	Tool adaption:	ER 32
	Coolant:	IC/Ext
	Please note:	demountable in left version
	Center distance [mm]:	100

Part-#	Name	
8 231 47 006	Boring bar holder Ø 25	
	Version:	left
	Shank size [mm]:	40.00
	Shank type:	VDI
	Tool adaption:	Ø 25
	Coolant:	IC/Ext
	Please note:	demountable in right version
	Center distance [mm]:	120
8 231 48 000	Tool holder HT 6	
	Weight [kg]:	6.080
	Notation:	offset
	Version:	left
	Shank size [mm]:	40.00
	Shank type:	VDI
	Tool adaption:	HT 6
	Coolant:	IC/Ext
	Center distance [mm]:	100
8 231 48 003	Boring bar holder Ø 32	
	Weight [kg]:	6.770
	Version:	left
	Shank size [mm]:	40.00
	Shank type:	VDI
	Tool adaption:	Ø 32
	Coolant:	IC/Ext
	Please note:	demountable in right version
	Center distance [mm]:	100
8 231 48 007	Boring bar holder Ø 32	
	Version:	left
	Shank size [mm]:	40.00
	Shank type:	VDI
	Tool adaption:	Ø 32
	Coolant:	IC/Ext
	Please note:	demountable in right version
	Center distance [mm]:	120
8 231 49 007	Boring bar holder Ø 40	
	Weight [kg]:	6.510
	Version:	left
	Shank size [mm]:	40.00
	Shank type:	VDI
	Tool adaption:	Ø 40
	Coolant:	IC/Ext
	Please note:	demountable in right version
	Center distance [mm]:	100
8 234 45 003	Combi facing holder sq. 25/20	
	Weight [kg]:	6.160
	Shank size [mm]:	40.00
	Shank type:	VDI
	Tool adaption:	Sq. 25/20
	Coolant:	EXT

Part-#	Name	
8 234 45 004	Combi facing holder sq. 25/20	
	Weight [kg]:	9.780
	Shank size [mm]:	40.00
	Shank type:	VDI
	Tool adaption:	Sq. 25/20
	Coolant:	EXT
8 239 45 005	Double collet chuck holder ER 25	
	Weight [kg]:	6.140
	Employment for:	Main- and sub spindle
	Shank size [mm]:	40.00
	Shank type:	VDI
	Tool adaption:	ER 25
	Coolant:	IC/Ext
	Center distance [mm]:	100
8 239 46 006	Double collet chuck holder ER 32	
	Weight [kg]:	6.390
	Employment for:	Main- and sub spindle
	Shank size [mm]:	40.00
	Shank type:	VDI
	Tool adaption:	ER 32
	Coolant:	IC/Ext
	Center distance [mm]:	100
8 239 47 003	Double boring bar holder Ø 25	
	Weight [kg]:	8.390
	Shank size [mm]:	40.00
	Shank type:	VDI
	Tool adaption:	Ø 25
	Coolant:	IC/Ext
	Center distance [mm]:	100
8 239 48 000	Double boring bar holder Ø 32	
	Shank size [mm]:	40.00
	Shank type:	VDI
	Tool adaption:	Ø 32
	Coolant:	IC/Ext
	Center distance [mm]:	100
8 239 48 009	Double boring bar holder Ø 32	
	Employment for:	Heavy duty cutting
	Shank size [mm]:	40.00
	Shank type:	VDI
	Tool adaption:	Ø 32
	Coolant:	IC/Ext
	Center distance [mm]:	100
8 239 49 007	Double boring bar holder Ø 40	
	Weight [kg]:	7.340
	Employment for:	Heavy duty cutting
	Shank size [mm]:	40.00
	Shank type:	VDI
	Tool adaption:	Ø 40
	Coolant:	IC/Ext
	Center distance [mm]:	100

Part-#	Name
--------	------

8 251 45 003	Combi double turning holder sq. 25/20	
	Weight [kg]:	5.420
	Shank size [mm]:	40.00
	Shank type:	VDI
	Tool adaption:	Sq. 25/20
	Coolant:	EXT
8 262 49 003	Stock stop VDI 40 - Ø 60 OD turret	
	Weight [kg]:	6.300
	Notation:	rotating
	Version:	left
	Shank size [mm]:	40.00
	Shank type:	VDI
	Coolant:	no
	Please note:	Lenght adjustable
	Center distance [mm]:	100
8 262 49 004	Stock stop VDI 40 - Ø 60 OD turret	
	Notation:	offset
	Version:	right
	Shank size [mm]:	40.00
	Shank type:	VDI
	Rotation max [1/min]:	8000
	Coolant:	no
	Center distance [mm]:	100

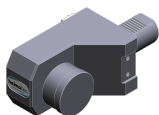

heimatec.u-tec®

heimatec.com

Products / Tool change systems /
u-tec® Tool-changing system



versions see catalog



heimatec.easy-quick

heimatec.com

Products / Tool change systems /
easy-quick HT quick-changing system



versions see catalog



heimatec.Capto™

heimatec.com

Products / Tool change systems /
heimatec.Capto™ quick-changing system



versions see catalog

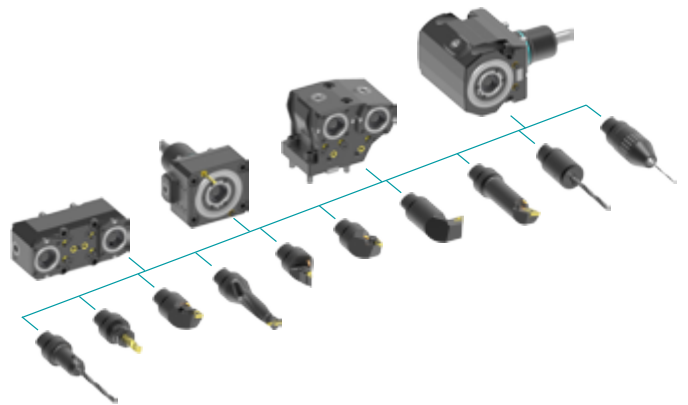

heimatec.accessories

heimatec.com

Products / Accessories



versions see catalog





● heimatec overseas branches

○ global representations of heimatec

heimatec[®]

heimatec GmbH
Präzisionswerkzeuge
Carl-Benz-Str. 4
77871 Renchen
Germany

T +49 7843 9466 0
www.heimatec.com
info@heimatec.com

Please find the contact details of our worldwide trading partners on our website:
<https://heimatec.com/business-partners>