

Mori Seiki
SL 200 MC/SMC



High-tech from heimatec - heimatec - Tools and systems for productive turning and milling

heimatec belongs to the international technology and quality leaders for precision tools and specializes in the development and production of high-precision static and live tools for all CNC lathes, CNC turn-/mill machines and CNC machining centers.

The range of products* spans from static BMT and VDI tool holders, live tools up to highly complex customer-specific individual solutions. heimatec, headquartered in Renchen, has a own subsidiary in Asia and India and numerous representatives as well as trading partners all over the world.

*OUR PRODCUTS

Static tool holders

Live tool units

Precision tools

Tools for turning and machining centres

Tools for swiss type lathes

Tool changing and uick-change systems

Tool systems for gear production

Digital tool management

This catalogue, including all its parts, is protected by copyright. Any use outside the restricted limitations of the Copyright Act without the consent of heimatec is inadmissible and liable to prosecution. This applies in particular to duplication, translation, microfilming and storage and processing in electronic systems.

heimatec GmbH reserves the right to make technical changes at any time without giving prior notice. This applies in particular to adjustments at any time to meet new or changed international standards, or in case of further developments of our products or manufacturing processes.

The current version of our General Terms and Conditions can be found on our website.

| Part-# | Name | |
|---------------------|--|------------------|
| 8 010 34 012 | Axial drilling and milling head ER 20 IC | |
| | Weight [kg]: | 5.640 |
| | Tool drive: | Flat (~DIN 1809) |
| | Shank size [mm]: | 32.00 |
| | Shank type: | BMT |
| | Tool adaption: | ER 20 |
| | Gear ratio [i]: | 1:1 |
| | Torque max [Nm]: | 50 |
| | Rotation max [1/min]: | 6000 |
| | Rotating direction: | same |
| | Coolant: | IC/Ext |
| | Pressure max [bar]: | 25 |
| 8 010 35 014 | Axial drilling and milling head ER 25 AX UT | |
| | Weight [kg]: | 5.290 |
| | Tool drive: | Flat (~DIN 1809) |
| | Shank size [mm]: | 32.00 |
| | Shank type: | BMT |
| | Tool adaption: | ER 25 A - u-tec |
| | Gear ratio [i]: | 1:1 |
| | Torque max [Nm]: | 50 |
| | Rotation max [1/min]: | 12000 |
| | Rotating direction: | same |
| | Coolant: | EXT |
| | Please note: | stronger bearing |
| 8 010 36 000 | Axial drilling and milling head ER 32 IC | |
| | Weight [kg]: | 5.560 |
| | Tool drive: | Flat (~DIN 1809) |
| | Shank size [mm]: | 32.00 |
| | Shank type: | BMT |
| | Tool adaption: | ER 32 |
| | Gear ratio [i]: | 1:1 |
| | Torque max [Nm]: | 50 |
| | Rotation max [1/min]: | 6000 |
| | Rotating direction: | same |
| | Coolant: | IC/Ext |
| | Pressure max [bar]: | 25 |
| 8 010 36 001 | Axial drilling and milling head ER 32 | |
| | Weight [kg]: | 5.520 |
| | Tool drive: | Flat (~DIN 1809) |
| | Shank size [mm]: | 32.00 |
| | Shank type: | BMT |
| | Tool adaption: | ER 32 |
| | Gear ratio [i]: | 1:1 |
| | Torque max [Nm]: | 50 |
| | Rotation max [1/min]: | 8000 |
| | Rotating direction: | same |
| | Coolant: | EXT |

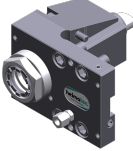
| Part-# | Name | |
|---|-----------------------|---|
|  | 8 010 36 007 | Axial drilling and milling head ER 32 AX UT |
| | Weight [kg]: | 5.470 |
| | Tool drive: | Flat (~DIN 1809) |
| | Shank size [mm]: | 32.00 |
| | Shank type: | BMT |
| | Tool adaption: | ER 32 A - u-tec |
| | Gear ratio [i]: | 1:1 |
| | Torque max [Nm]: | 50 |
| | Rotation max [1/min]: | 8000 |
| | Rotating direction: | same |
| | Coolant: | EXT |
| Please note: | stronger bearing | |
| | 8 010 36 008 | Axial drilling and milling head ER 32 IC |
| Tool drive: | Flat (~DIN 1809) | |
| Shank size [mm]: | 32.00 | |
| Shank type: | BMT | |
| Tool adaption: | ER 32 | |
| Gear ratio [i]: | 1:1 | |
| Torque max [Nm]: | 50 | |
| Rotation max [1/min]: | 6000 | |
| Rotating direction: | same | |
| Coolant: | IC/Ext | |
| Pressure max [bar]: | 25 | |
| Please note: | Combi bearing | |
| | 8 010 36 009 | Axial drilling and milling head ER 32 AX UT IC |
| Weight [kg]: | 5.550 | |
| Tool drive: | Flat (~DIN 1809) | |
| Shank size [mm]: | 32.00 | |
| Shank type: | BMT | |
| Tool adaption: | ER 32 A - u-tec | |
| Gear ratio [i]: | 1:1 | |
| Torque max [Nm]: | 50 | |
| Rotation max [1/min]: | 6000 | |
| Rotating direction: | same | |
| Coolant: | IC/Ext | |
| Pressure max [bar]: | 25 | |
| Please note: | stronger bearing | |
| | 8 010 36 016 | Axial drilling and milling head ER 32 AX UT IC |
| Weight [kg]: | 5.500 | |
| Tool drive: | Flat (~DIN 1809) | |
| Shank size [mm]: | 32.00 | |
| Shank type: | BMT | |
| Tool adaption: | ER 32 A - u-tec | |
| Gear ratio [i]: | 1:1 | |
| Torque max [Nm]: | 50 | |
| Rotation max [1/min]: | 12000 | |
| Rotating direction: | same | |
| Coolant: | IC/Ext | |
| Pressure max [bar]: | 25 | |
| Please note: | stronger bearing | |

| Part-# | Name | |
|---------------------|---|--------------------|
| 8 010 37 000 | Axial drilling and milling head HT 5 | |
| | Weight [kg]: | 5.510 |
| | Tool drive: | Flat (~DIN 1809) |
| | Shank size [mm]: | 32.00 |
| | Shank type: | BMT |
| | Tool adaption: | HT 5 |
| | Gear ratio [i]: | 1:1 |
| | Torque max [Nm]: | 50 |
| | Rotation max [1/min]: | 8000 |
| | Rotating direction: | same |
| | Coolant: | EXT |
| 8 010 37 001 | Axial drilling and milling head HT 5 IC | |
| | Weight [kg]: | 5.530 |
| | Tool drive: | Flat (~DIN 1809) |
| | Shank size [mm]: | 32.00 |
| | Shank type: | BMT |
| | Tool adaption: | HT 5 |
| | Gear ratio [i]: | 1:1 |
| | Torque max [Nm]: | 50 |
| | Rotation max [1/min]: | 6000 |
| | Rotating direction: | same |
| | Coolant: | IC/Ext |
| | Pressure max [bar]: | 25 |
| 8 010 37 002 | Axial drilling and milling head ER 40 IC | |
| | Weight [kg]: | 5.800 |
| | Tool drive: | Flat (~DIN 1809) |
| | Shank size [mm]: | 32.00 |
| | Shank type: | BMT |
| | Tool adaption: | ER 40 |
| | Gear ratio [i]: | 1:1 |
| | Torque max [Nm]: | 50 |
| | Rotation max [1/min]: | 6000 |
| | Rotating direction: | same |
| | Coolant: | IC/Ext |
| | Pressure max [bar]: | 25 |
| 8 011 34 004 | Axial milling head universal arbor 16 | |
| | Weight [kg]: | 5.470 |
| | Tool drive: | Flat (~DIN 1809) |
| | Shank size [mm]: | 32.00 |
| | Shank type: | BMT |
| | Tool adaption: | Universal arbor 16 |
| | Gear ratio [i]: | 1:1 |
| | Torque max [Nm]: | 50 |
| | Rotation max [1/min]: | 6000 |
| | Rotating direction: | same |
| | Coolant: | EXT |
| 8 011 35 000 | Axial milling head universal arbor 22 | |
| | Weight [kg]: | 5.580 |
| | Tool drive: | Flat (~DIN 1809) |
| | Shank size [mm]: | 32.00 |
| | Shank type: | BMT |
| | Tool adaption: | Universal arbor 22 |
| | Gear ratio [i]: | 1:1 |
| | Torque max [Nm]: | 50 |

| Part-# | Name | |
|---------------------|--|---------------------------|
| | Rotation max [1/min]: | 6000 |
| | Rotating direction: | same |
| | Coolant: | EXT |
| 8 030 34 005 | Radial drilling and milling head ER 20 | |
| | Weight [kg]: | 10.680 |
| | Tool drive: | Flat (~DIN 1809) |
| | Shank size [mm]: | 32.00 |
| | Shank type: | BMT |
| | Tool adaption: | ER 20 |
| | Gear ratio [i]: | 1:3 |
| | Torque max [Nm]: | 8 |
| | Rotation max [1/min]: | 12000 |
| | Rotating direction: | opposite |
| | Coolant: | EXT |
| | Center distance [mm]: | 55 |
| 8 030 34 012 | Radial drilling and milling head ER 20 IC | |
| | Employment for: | Main spindle |
| | Tool drive: | Flat (~DIN 1809) |
| | Shank size [mm]: | 32.00 |
| | Shank type: | BMT |
| | Tool adaption: | ER 20 |
| | Gear ratio [i]: | 1:1 |
| | Torque max [Nm]: | 50 |
| | Rotation max [1/min]: | 6000 |
| | Rotating direction: | opposite |
| | Coolant: | IC/Ext |
| | Pressure max [bar]: | 25 |
| | Center distance [mm]: | 55 |
| 8 030 34 013 | Radial drilling and milling head ER 20 IC | |
| | Employment for: | Sub spindle |
| | Tool drive: | Flat (~DIN 1809) |
| | Shank size [mm]: | 32.00 |
| | Shank type: | BMT |
| | Tool adaption: | ER 20 |
| | Gear ratio [i]: | 1:1 |
| | Torque max [Nm]: | 50 |
| | Rotation max [1/min]: | 6000 |
| | Rotating direction: | same |
| | Coolant: | IC/Ext |
| | Pressure max [bar]: | 25 |
| | Please note: | note center distance 55 ! |
| | Center distance [mm]: | 55 |
| 8 030 35 014 | Radial drilling and milling head ER 25 AX UT IC | |
| | Weight [kg]: | 10.320 |
| | Employment for: | Sub spindle |
| | Tool drive: | Flat (~DIN 1809) |
| | Shank size [mm]: | 32.00 |
| | Shank type: | BMT |
| | Tool adaption: | ER 25 A - u-tec |
| | Gear ratio [i]: | 1:2 |
| | Torque max [Nm]: | 16 |
| | Rotation max [1/min]: | 12000 |
| | Rotating direction: | opposite |
| | Coolant: | IC/Ext |

| Part-# | Name | |
|---------------------|--|---------------------------|
| | Pressure max [bar]: | 140 |
| | Please note: | note center distance 55 ! |
| | Center distance [mm]: | 55 |
| 8 030 35 027 | Radial drilling and milling head ER 25 AX UT IC | |
| | Weight [kg]: | 10.350 |
| | Employment for: | Main spindle |
| | Tool drive: | Flat (~DIN 1809) |
| | Shank size [mm]: | 32.00 |
| | Shank type: | BMT |
| | Tool adaption: | ER 25 A - u-tec |
| | Gear ratio [i]: | 1:2 |
| | Torque max [Nm]: | 16 |
| | Rotation max [1/min]: | 12000 |
| | Rotating direction: | opposite |
| | Coolant: | IC/Ext |
| | Pressure max [bar]: | 140 |
| | Please note: | note center distance 55 ! |
| | Center distance [mm]: | 55 |
| 8 030 35 028 | Radial drilling and milling head ER 25 AX UT | |
| | Weight [kg]: | 9.970 |
| | Employment for: | Main spindle |
| | Tool drive: | Flat (~DIN 1809) |
| | Shank size [mm]: | 32.00 |
| | Shank type: | BMT |
| | Tool adaption: | ER 25 A - u-tec |
| | Gear ratio [i]: | 1:2 |
| | Torque max [Nm]: | 16 |
| | Rotation max [1/min]: | 12000 |
| | Rotating direction: | opposite |
| | Coolant: | EXT |
| | Please note: | note center distance 55 ! |
| | Center distance [mm]: | 55 |
| 8 030 36 001 | Radial drilling and milling head ER 32 | |
| | Weight [kg]: | 10.320 |
| | Tool drive: | Flat (~DIN 1809) |
| | Shank size [mm]: | 32.00 |
| | Shank type: | BMT |
| | Tool adaption: | ER 32 |
| | Gear ratio [i]: | 1:1 |
| | Torque max [Nm]: | 50 |
| | Rotation max [1/min]: | 12000 |
| | Rotating direction: | opposite |
| | Coolant: | EXT |
| | Center distance [mm]: | 55 |
| 8 030 36 005 | Radial drilling and milling head ER 32 | |
| | Weight [kg]: | 10.310 |
| | Tool drive: | Flat (~DIN 1809) |
| | Shank size [mm]: | 32.00 |
| | Shank type: | BMT |
| | Tool adaption: | ER 32 |
| | Gear ratio [i]: | 2:1 |
| | Torque max [Nm]: | 63 |
| | Rotation max [1/min]: | 3000 |
| | Rotating direction: | opposite |

| Part-# | Name | |
|---------------------|--|------------------|
| | Coolant: | EXT |
| | Center distance [mm]: | 55 |
| 8 030 36 011 | Radial drilling and milling head ER 32 AX UT | |
| | Weight [kg]: | 10.240 |
| | Tool drive: | Flat (~DIN 1809) |
| | Shank size [mm]: | 32.00 |
| | Shank type: | BMT |
| | Tool adaption: | ER 32 A - u-tec |
| | Gear ratio [i]: | 1:1 |
| | Torque max [Nm]: | 50 |
| | Rotation max [1/min]: | 12000 |
| | Rotating direction: | opposite |
| | Coolant: | EXT |
| | Center distance [mm]: | 55 |
| 8 030 36 012 | Radial drilling and milling head ER 32 AX UT IC | |
| | Weight [kg]: | 10.470 |
| | Tool drive: | Flat (~DIN 1809) |
| | Shank size [mm]: | 32.00 |
| | Shank type: | BMT |
| | Tool adaption: | ER 32 A - u-tec |
| | Gear ratio [i]: | 1:1 |
| | Torque max [Nm]: | 50 |
| | Rotation max [1/min]: | 6000 |
| | Rotating direction: | opposite |
| | Coolant: | IC/Ext |
| | Pressure max [bar]: | 140 |
| | Center distance [mm]: | 55 |
| 8 030 36 021 | Radial drilling and milling head ER 32 AX UT IC | |
| | Weight [kg]: | 10.450 |
| | Tool drive: | Flat (~DIN 1809) |
| | Shank size [mm]: | 32.00 |
| | Shank type: | BMT |
| | Tool adaption: | ER 32 A - u-tec |
| | Gear ratio [i]: | 1:1 |
| | Torque max [Nm]: | 50 |
| | Rotation max [1/min]: | 12000 |
| | Rotating direction: | opposite |
| | Coolant: | IC/Ext |
| | Pressure max [bar]: | 140 |
| | Center distance [mm]: | 55 |
| 8 030 37 001 | Radial drilling and milling head HT 5 IC | |
| | Tool drive: | Flat (~DIN 1809) |
| | Shank size [mm]: | 32.00 |
| | Shank type: | BMT |
| | Tool adaption: | HT 5 |
| | Gear ratio [i]: | 1:1 |
| | Torque max [Nm]: | 50 |
| | Rotation max [1/min]: | 6000 |
| | Rotating direction: | opposite |
| | Coolant: | IC/Ext |
| | Pressure max [bar]: | 140 |
| | Center distance [mm]: | 55 |

| Part-# | Name | |
|---------------------|---|---------------------------------|
| 8 030 37 007 | Radial drilling and milling head Weldon 1" | |
| | Weight [kg]: | 10.890 |
| | Tool drive: | Flat (~DIN 1809) |
| | Shank size [mm]: | 32.00 |
| | Shank type: | BMT |
| | Tool adaption: | Weldon (DIN 1835 b) 1" (25,4mm) |
| | Gear ratio [i]: | 2:1 |
| | Torque max [Nm]: | 63 |
| | Rotation max [1/min]: | 3000 |
| | Rotating direction: | opposite |
| | Coolant: | EXT |
| | Center distance [mm]: | 55 |
| 8 031 36 000 | Radial polygon head arbor 27 | |
| | Weight [kg]: | 10.860 |
| | Employment for: | Main spindle |
| | Tool drive: | Flat (~DIN 1809) |
| | Shank size [mm]: | 32.00 |
| | Shank type: | BMT |
| | Tool adaption: | Polygon arbor 27 |
| | Gear ratio [i]: | 1:1 |
| | Torque max [Nm]: | 50 |
| | Rotation max [1/min]: | 6000 |
| | Rotating direction: | opposite |
| | Coolant: | EXT |
| | Please note: | stronger bearing |
| 8 037 34 001 | Woodruff keycutter ER 20 AX | |
| | Tool drive: | Flat (~DIN 1809) |
| | Shank size [mm]: | 32.00 |
| | Shank type: | BMT |
| | Tool adaption: | ER 20 A |
| | Gear ratio [i]: | 1,333:1 |
| | Torque max [Nm]: | 32 |
| | Rotation max [1/min]: | 4000 |
| | Rotating direction: | opposite |
| | Coolant: | EXT |
| | Center distance [mm]: | 75 |
| | Offset [mm]: | 8 |
| 8 039 35 004 | Radial drilling and milling head ER 25 AX UT | |
| | Weight [kg]: | 10.480 |
| | Version: | double spindle |
| | Tool drive: | Flat (~DIN 1809) |
| | Shank size [mm]: | 32.00 |
| | Shank type: | BMT |
| | Tool adaption: | ER 25 u-tec |
| | Gear ratio [i]: | 1:1 |
| | Torque max [Nm]: | 50 |
| | Rotation max [1/min]: | 12000 |
| | Rotating direction: | same/opposite |
| | Coolant: | EXT |
| | Center distance [mm]: | 55 |

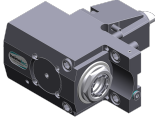
| Part-# | Name | |
|---|--|-------------------|
| 8 039 36 002 | Radial drilling and milling head ER 32 AX UT | |
| | Weight [kg]: | 10.710 |
| | Version: | double spindle |
| | Tool drive: | Flat (~DIN 1809) |
| | Shank size [mm]: | 32.00 |
| | Shank type: | BMT |
| | Tool adaption: | ER 32 u-tec |
| | Gear ratio [i]: | 1:1 |
| | Torque max [Nm]: | 50 |
| | Rotation max [1/min]: | 12000 |
| | Rotating direction: | same/opposite |
| | Coolant: | EXT |
| | Center distance [mm]: | 55 |
| 8 039 36 004 | Radial drilling and milling head ER 32 AX UT IC | |
|  | Version: | double spindle |
| | Tool drive: | Flat (~DIN 1809) |
| | Shank size [mm]: | 32.00 |
| | Shank type: | BMT |
| | Tool adaption: | ER 32 u-tec |
| | Gear ratio [i]: | 1:1 |
| | Torque max [Nm]: | 50 |
| | Rotation max [1/min]: | 10000 |
| | Rotating direction: | same/opposite |
| | Coolant: | IC/Ext |
| | Pressure max [bar]: | 70 |
| | Please note: | stronger bearing |
| | Center distance [mm]: | 55 |
| 8 040 34 007 | Universal head + 99°/-77° adj. ER16 AX UT | |
| | Weight [kg]: | 6.890 |
| | Tool drive: | Flat (~DIN 1809) |
| | Shank size [mm]: | 32.00 |
| | Shank type: | BMT |
| | Tool adaption: | ER 16 A - u-tec |
| | Gear ratio [i]: | 1:1 |
| | Torque max [Nm]: | 20 |
| | Rotation max [1/min]: | 6000 |
| | Rotating direction: | opposite |
| | Coolant: | EXT |
| | Please note: | Note swivel range |
| | Center distance [mm]: | 34 |
| 8 040 34 010 | Universal head + 99°/-77° adj. ER16AX UTIK | |
| | Weight [kg]: | 6.920 |
| | Tool drive: | Flat (~DIN 1809) |
| | Shank size [mm]: | 32.00 |
| | Shank type: | BMT |
| | Tool adaption: | ER 16 A - u-tec |
| | Gear ratio [i]: | 1:2 |
| | Torque max [Nm]: | 12 |
| | Rotation max [1/min]: | 12000 |
| | Rotating direction: | opposite |
| | Coolant: | IC/Ext |
| | Pressure max [bar]: | 25 |
| | Please note: | Note swivel range |
| | Center distance [mm]: | 34 |

| Part-# | Name | |
|---------------------|--|-------------------------|
| 8 040 34 011 | Universal head + 99°/-77° adj. ER20 AX UT | |
| | Weight [kg]: | 7.070 |
| | Tool drive: | Flat (~DIN 1809) |
| | Shank size [mm]: | 32.00 |
| | Shank type: | BMT |
| | Tool adaption: | ER 20 A - u-tec |
| | Gear ratio [i]: | 1:1 |
| | Torque max [Nm]: | 20 |
| | Rotation max [1/min]: | 6000 |
| | Rotating direction: | opposite |
| | Coolant: | EXT |
| | Please note: | Note swivel range |
| | Center distance [mm]: | 34 |
| 8 053 34 014 | Multispindle radial head ER 16 AX UT | |
| | Weight [kg]: | 9.860 |
| | Employment for: | Main spindle |
| | Version: | 2-spindles |
| | Tool drive: | Flat (~DIN 1809) |
| | Shank size [mm]: | 32.00 |
| | Shank type: | BMT |
| | Tool adaption: | ER 16 A - u-tec |
| | Gear ratio [i]: | 1:2 |
| | Torque max [Nm]: | 25/Sp. |
| | Rotation max [1/min]: | 12000 |
| | Rotating direction: | same |
| | Coolant: | EXT |
| | Please note: | Check applicability |
| | Center distance [mm]: | 55 |
| 8 202 20 013 | Basic holder longitudinal seat FN 12 | |
| | Weight [kg]: | 1.750 |
| | Shank type: | BMT |
| | Machine adaption: | Centering key slot b 25 |
| | Tool adaption: | Interface FN 12 |
| | Coolant: | EXT |
| | Center distance [mm]: | 7 |
| 8 224 25 000 | Universal turning holder sq. 25 | |
| | Weight [kg]: | 3.560 |
| | Shank type: | BMT |
| | Machine adaption: | Centering key slot b 25 |
| | Tool adaption: | Sq. 25 |
| | Coolant: | EXT |
| 8 224 25 001 | Universal turning holder sq. 25 | |
| | Weight [kg]: | 4.760 |
| | Shank type: | BMT |
| | Machine adaption: | Centering key slot b 25 |
| | Tool adaption: | Sq. 25 |
| | | Sq. 25 |
| | Coolant: | EXT |
| | Please note: | long version |

| Part-# | Name | |
|---------------------|---|-------------------------|
| 8 240 29 002 | Boring bar holder Ø 40 | |
| | Weight [kg]: | 3.920 |
| | Shank type: | BMT |
| | Machine adaption: | Centering key slot b 25 |
| | Tool adaption: | Ø 40 |
| | Coolant: | IC/Ext |
| | Center distance [mm]: | 40 |
| 8 240 29 007 | Boring bar holder Ø 40 | |
| | Weight [kg]: | 6.180 |
| | Version: | long |
| | Shank type: | BMT |
| | Machine adaption: | Centering key slot b 25 |
| | Tool adaption: | Ø 40 |
| | Coolant: | IC/Ext |
| | Center distance [mm]: | 40 |
| 8 240 29 021 | Boring bar holder Ø 50 | |
| | Weight [kg]: | 5.330 |
| | Version: | long version |
| | Shank type: | BMT |
| | Machine adaption: | Centering key slot b 25 |
| | Tool adaption: | Ø 50 |
| | Coolant: | IC/Ext |
| | Center distance [mm]: | 40 |
| 8 244 25 000 | Combi facing holder sq. 25 | |
| | Weight [kg]: | 5.900 |
| | Shank type: | BMT |
| | Machine adaption: | Centering key slot b 25 |
| | Tool adaption: | Sq. 25 |
| | Coolant: | EXT |
| | Please note: | long version |
| 8 251 25 002 | Combi double turning holder sq. 25 | |
| | Weight [kg]: | 5.290 |
| | Shank type: | BMT |
| | Machine adaption: | Centering key slot b 25 |
| | Tool adaption: | Sq. 25 Sq. 25 |
| | Coolant: | EXT |
| 8 253 28 001 | Double boring bar holder Ø 32 | |
| | Weight [kg]: | 5.680 |
| | Employment for: | Main- and sub spindle |
| | Shank type: | BMT |
| | Machine adaption: | Centering key slot b 25 |
| | Tool adaption: | Ø 32 Ø 32 |
| | Coolant: | IC/Ext |
| | Center distance [mm]: | 40/85 |

| Part-# | Name | |
|---------------------|--|-------------------------|
| 8 253 28 006 | Double boring bar holder Ø 1 1/4" | |
| | Weight [kg]: | 5.710 |
| | Employment for: | Main- and sub spindle |
| | Shank type: | BMT |
| | Machine adaption: | Centering key slot b 25 |
| | Tool adaption: | Ø 1 1/4" (31,75mm) |
| | | Ø 1 1/4" (31,75mm) |
| | Coolant: | IC/Ext |
| | Center distance [mm]: | 40/85 |
| 8 253 28 009 | Multiple boring bar holder Ø 32 | |
| | Weight [kg]: | 7.930 |
| | Employment for: | Main- and sub spindle |
| | Version: | double spindle |
| | Shank type: | BMT |
| | Machine adaption: | Centering key slot b 25 |
| | Tool adaption: | Ø 32 |
| | | Ø 32 |
| | | Ø 32 |
| | | Ø 32 |
| | Coolant: | IC/Ext |
| | Center distance [mm]: | 40/ 85 |



heimatec.u-tec®

heimatec.com

Products / Tool change systems /
u-tec® Tool-changing system



versions see catalog

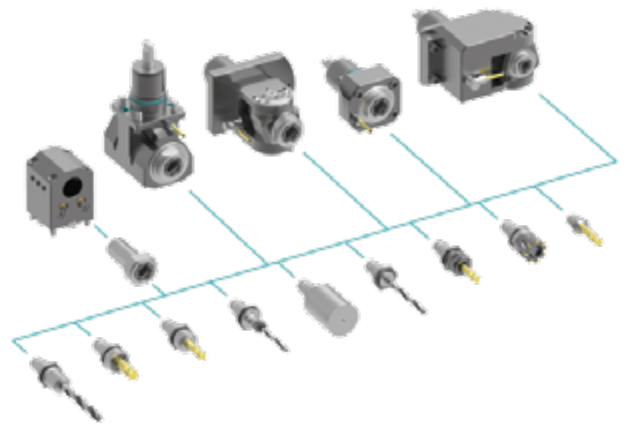

heimatec.easy-quick

heimatec.com

Products / Tool change systems /
easy-quick HT quick-changing system



versions see catalog

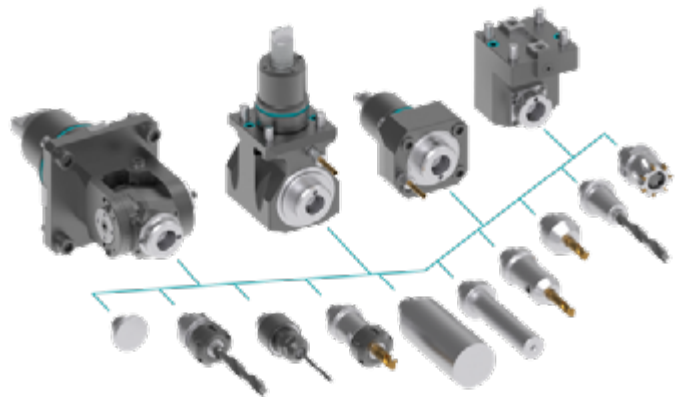

heimatec.Capto™

heimatec.com

Products / Tool change systems /
heimatec.Capto™ quick-changing system



versions see catalog

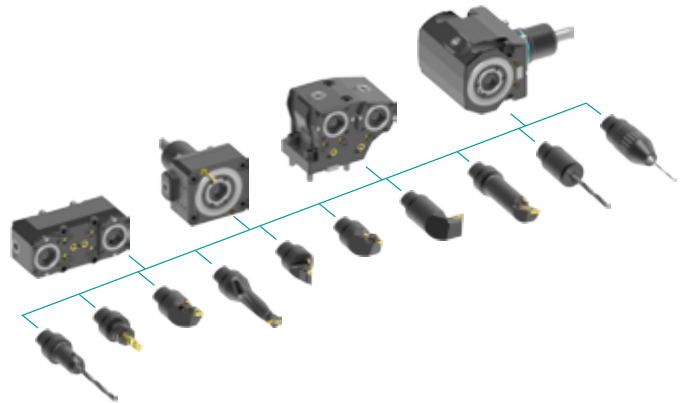

heimatec.accessories

heimatec.com

Products / Accessories



versions see catalog





● heimatec overseas branches

○ global representations of heimatec

heimatec[®]

heimatec GmbH
Präzisionswerkzeuge
Carl-Benz-Str. 4
77871 Renchen
Germany

T +49 7843 9466 0
www.heimatec.com
info@heimatec.com

Please find the contact details of our worldwide trading partners on our website:
<https://heimatec.com/business-partners>