

Translation of the original assembly instruction Collet chuck holder

1	About this manual.....	5
1.1	Purpose.....	5
1.2	Version information.....	5
1.3	Contact information.....	5
1.4	Information on the product.....	5
1.5	Other applicable documents.....	5
1.6	Means of representation.....	6
1.7	Warranty.....	6
1.8	Labeling/nameplate.....	7
2	Safety.....	8
2.1	Safety instructions.....	8
2.2	Warnings.....	9
2.2.1	Structure of the warnings.....	9
2.2.2	Meaning of the signal words and symbols.....	9
2.3	Personnel requirements.....	10
2.4	Protective devices.....	11
3	Overview.....	12
3.1	Intended use.....	12
3.2	Graphic description.....	12
3.3	Recommended tightening torques.....	13
3.4	Technical data.....	14
3.5	Coolant supply.....	14
3.5.1	Product with external coolant supply.....	14
3.5.2	Product with external and internal coolant supply.....	14
4	Transport, handling and storage.....	18
4.1	Transport method.....	18
4.2	Unpacking.....	18
4.3	Storage.....	18
5	Assembly and commissioning.....	19
5.1	Modification.....	20
5.2	Mounting in the machine.....	20
5.2.1	VDI interface.....	21
5.2.2	BMT interface variants.....	22
5.3	Alignment of the product.....	28
5.3.1	Permanent fixing.....	28
5.3.2	Adjustable fixing.....	29
5.3.3	Preadjustable fixing.....	30

5.4	Mounting the cutting tool/accessories	31
5.4.1	Collet chuck holder	31
5.4.2	Fitting and dismantling DS sealing washers.....	32
5.4.3	u-tec® UT.....	34
5.4.4	HT/UT mounting block.....	36
5.4.5	icosen® sensor unit.....	36
6	Maintenance	38
6.1	Cleaning.....	38
7	Troubleshooting and repair	39
7.1	Action in case of faults.....	39
7.2	Repair	39
8	Disposal.....	40

1 About this manual

1.1 Purpose

The objective of this manual is to provide users with all necessary information to enable effective and safe use of the product during its entire life cycle.

This manual is directed at all persons who are assigned to transport, store, assemble, operate, maintain, troubleshoot, and dispose of the product.

1.2 Version information

The issue status of this manual is stated on the cover page and in the footers on every page.

Always keep and use the current version of all documentation. Use of an outdated version of this manual or the required and additional documentation can result in improper handling of the product.

1.3 Contact information

Manufacturer	heimatec GmbH
Address	Carl-Benz-Str. 4 77871 Renchen Germany
Phone	+49 7843 9466 0
Email	info@heimatec.com
Internet	www.heimatec.com

1.4 Information on the product

Name	Collet chuck holder
------	---------------------

1.5 Other applicable documents

- General Terms and Conditions of Business (T&C)
- Dimensioned drawing of the purchased product

The dimensioned drawing is tied to the revision of the product. Always use the serial number to search for the correct dimensioned drawing on the website.

The documents can be downloaded from www.heimatec.com.

1.6 Means of representation

The following presentation formats are used in this manual:

Instructions

Requirements for an instruction are represented with a checkmark.

The steps to be carried out are numbered.

Results of the individual steps are identified by an arrow. The overall result of an instruction is highlighted by a white arrow in a black circle.

- Example** ✓ Requirement
1. Instruction (Step 1)
 2. Instruction (Step 2)
⇒ Result or system reaction to step 2
 3. Instruction (Step 3)
➡ Overall result of the instruction

Lists

Lists without a mandatory order are shown as a list with bullet points.

- Example** — Property A
- Detail 1
 - Detail 2
- Property B
- Detail 1
 - Detail 2

Cross references

Cross-references are represented by the name of the section, square parentheses, an arrow and the page number.

- Example** Means of representation [▶ 6]

1.7 Warranty

The implied warranty applies from the factory delivery date if the product is used as intended under the following conditions:

- Comply with the ambient and operating conditions
- The customer does not make any changes to the product
- Parts in contact with the workpiece and wear parts are not covered by the warranty

1.8 Labeling/nameplate

Each product delivered by heimatec has an item number (e.g. 8 030 56 072) and a serial number (z.B. 3747/24:01). Additional information may be provided, depending on the tool type.

Additional information such as:

- i = gear ratio
- n_{\max} = speed
- p_{\max} = max. coolant pressure (see also pxn diagrams under Version with low-pressure seal and Version with high-pressure seal)
- T_{\max} = torque
- Product's direction of rotation from drive (n_1) to output (n_2)
 - = same direction (climb cutting)
 - \neq opposite direction (against the feed)

Part No.	8 030 56 072
Serial No.	3747 / 24:01
i	= 1:1
n_{\max}	= 6000 min^{-1}
p_{\max}	= 80 bar / EK
T_{\max}	= 50 Nm
n_1	$\neq n_2$

Fig. 1: Example of a nameplate

2 Safety

2.1 Safety instructions

This product is partly completed machinery as defined in the EU Machinery Directive 2006/42/EC. The product is intended for installation in a machine.

However, the product can nonetheless cause hazards if the safety instructions and warnings in the assembly manual are disregarded. The safety instructions in this section help you to avoid personal injuries and damage to property.

The owner/operating company must ensure that all safety instructions and warnings are understood and followed. Make sure that all persons who work with the product have read and understood the complete assembly manual before starting their work.

Improper handling can cause the product to pose dangers, which can lead to severe injuries and substantial damage to property.

Comply with the following safety instructions:

- Only qualified and instructed personnel may carry out work on the product
- Observe the country-specific accident prevention regulations and the general safety instructions, and comply with all provisions of the occupational safety law
- Only use the product in machines that meet the current safety regulations
- Use suitable assembly and transport equipment, and take precautions against getting jammed and crushing
- Use a suitable base/surface for repair and maintenance work and secure the product against unintentional movements
- Refrain from any way of working that has a negative effect on the product's functions and operating safety
- Do not expose the product to any corrosive fluids
- Only change cutting tools outside the machine tool
- Before starting up the product, secure the danger zone with a suitable protection measure
- During operation, do not reach into the open mechanisms and movement area of the product
- Check important components for damage before each use
- Do not use damaged products

2.2 Warnings

Preceding warnings

Warnings that relate to a certain part or section of the assembly manual (for example, all steps of a whole instruction), are at the beginning of the respective part.

Integrated warnings

Warnings that only relate to one part of a section (for example, to an individual step of an instruction), are at the relevant place within a section.

2.2.1 Structure of the warnings

All warnings in this document are structured as follows:

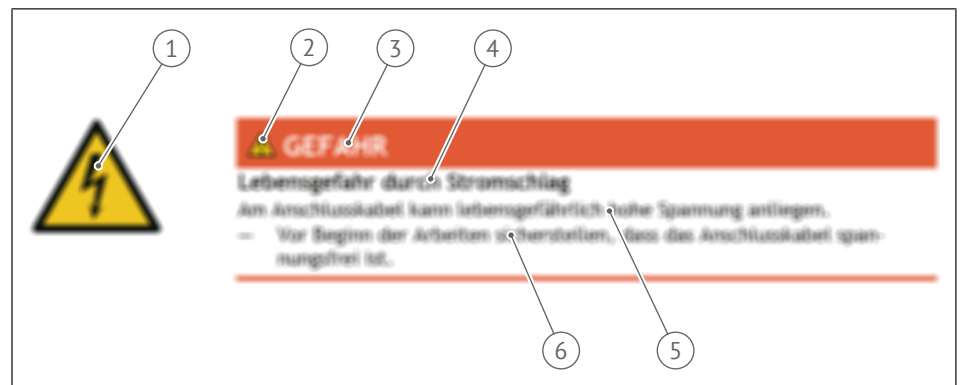

Fig. 2: Structure of the warnings

1	Hazard-specific symbol	2	Hazard symbol
3	Signal word	4	Type and source of the danger
5	Possible consequences if disregarded	6	Procedure to prevent the hazard





2.2.2 Meaning of the signal words and symbols

The following signal words are used in this document:

Signal word	Meaning, consequences if not prevented
DANGER	Indicates a dangerous situation that results in death or serious injuries.
WARNING	Indicates a potentially dangerous situation that could result in death or serious injuries.
CAUTION	Indicates a potentially dangerous situation that could result in minor or slight injuries.
NOTICE	Indicates a potentially dangerous situation that could result in damage to property or the environment.

Tab. 1: Meaning of the signal words

The following symbols for hazards, warnings, mandatory requirements, and prohibitions are used in this document:

Symbol	Meaning
	General warning of a hazard
	Warning: Hot surface
	Warning: Sharp edges
	Warning: Electromagnetic fields

Tab. 2: Warning sign

2.3 Personnel requirements

The product is intended for use by qualified personnel only. It is assumed that they have skills in use of this tool system.

The operating personnel must meet the following requirements:

- The personnel must follow the safety instructions and heed warnings of danger
- The personnel must keep the machine and the workplace clean
- Unauthorized persons must keep away from the machine

Persons whose responsiveness is influenced, for example, by drugs, alcohol, or medication may not work on or at the machine.

Qualifications The tasks described in this manual set certain requirements for the qualifications of the assigned personnel. Inadequately qualified personnel are unable to assess the risks involved in handling the machine correctly and expose themselves and others to the risk of injuries. The presence of inadequately qualified personnel in the work area/danger zone of the product is prohibited.

Qualified personnel Qualified personnel are persons whose technical training, knowledge, and experience, as well as their knowledge of the relevant standards and provisions, enable them to carry out and evaluate the work assigned to them, and to identify potential hazards independently. These persons are familiar with the product's assembly manual. Qualified personnel are mechanics, electricians, mechatronics technicians, and technicians.

Personal protective equipment Personal protective equipment is used/worn to protect the health and safety of persons during their work. Note and follow the relevant regulations for the higher-level area (control station, hall, etc.). The specified protective equipment must be worn.

- Wear protective gloves and goggles when handling hazardous substances
- In case of moving components, wear close-fitting protective clothing and additional hairnet for long hair
- Always wear suitable protective equipment such as protective gloves, safety footwear, and work clothing with close-fitting sleeves

2.4 Protective devices

As soon as the product is installed in a suitable machine, the protective devices of this machine take effect.

3 Overview

3.1 Intended use

The sole intended purpose of the product is the clamping of machining tools in machine tools for forming workpieces made of the following materials:

- Steel
- Aluminum
- Nonferrous and noble metals
- Plastics
- Glass

Intended use also includes the following points:

- The product may only be used within the scope of its technical data
- The product is intended for installation in a machine
- The applicable guidelines and directives on installation in a machine must be noted and complied with
- Follow all safety and assembly instructions

Deviating use of the product is deemed to be not intended use or rather misuse. The manufacturer is not liable for any resulting damage.

3.2 Graphic description

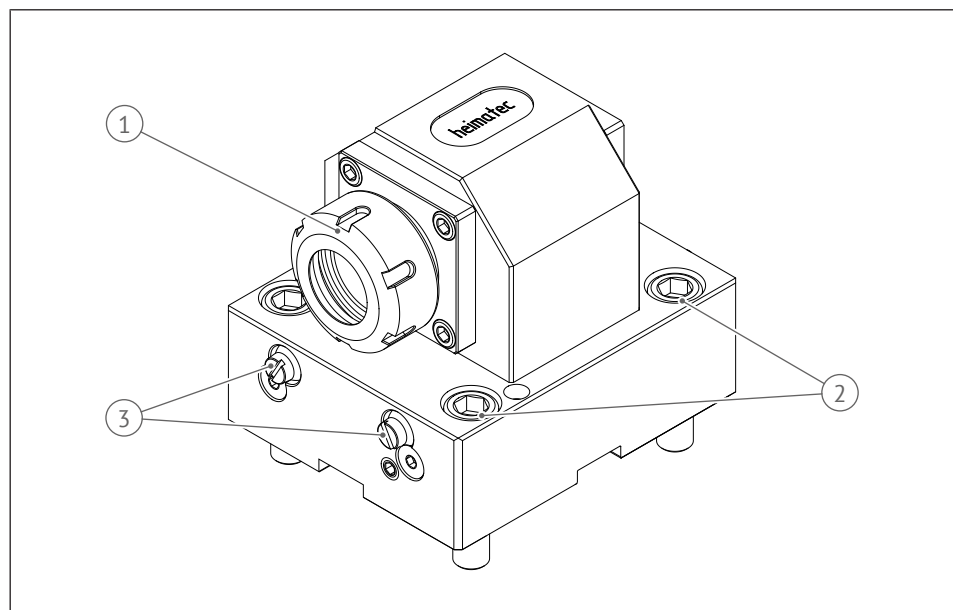

Fig. 3: Components overview

1	Tool holder	2	Fastening screws
3	External coolant supply		

3.3 Recommended tightening torques

Recommended tightening torques for cylinder head screws

Thread	Coefficient of friction	Strength class		
		8.8	10.9	12.9
M4	0.14	3 Nm	4 Nm	5 Nm
M5	0.14	6 Nm	8 Nm	10 Nm
M6	0.14	10 Nm	14 Nm	17 Nm
M8	0.14	25 Nm	35 Nm	42 Nm
M10	0.14	50 Nm	71 Nm	85 Nm
M12	0.14	87 Nm	122 Nm	147 Nm
M16	0.14	210 Nm	300 Nm	360 Nm

Tab. 3: Tightening torques for cylinder head screws



NOTICE

The recommended tightening torques for countersunk screws are 20% smaller.

Recommended tightening torques for collet chucks

Hi-Q®/ER: See REGO-FIX® catalog for information.

Recommended tightening torques for UT clamping nuts

UT16	UT 20	UT 25	UT 32	UT 40
40 Nm	55 Nm	60 Nm	80 Nm	100 Nm

Tab. 4: Tightening torques for UT clamping nuts



NOTICE

The maximum tightening torque must not exceed 15% above the recommended values.

Recommended tightening torques for HT collet screw

HT 2	HT 3	HT 4	HT 5	HT 6	HT 7
2.5 Nm	4 Nm	8 Nm	12 Nm	28 Nm	52 Nm

Tab. 5: Tightening torques for HT collet screw



NOTICE

The maximum tightening torque must not exceed 15% above the recommended values.

Maximum tightening torques for heimatec.Capto™ clamping bolts

Type				
C3	C4	C5	C6	C8
35 Nm	50 Nm	70 Nm	90 Nm	130 Nm

Tab. 6: Maximum tightening torques for heimatec.Capto™ clamping bolts

3.4 Technical data

Parameter	Value
Cooling lubricant	Quality according to ISO 4406:1999 Code 17/15/12, SAE 749 Class 3 or NAS 1638 Class 6 maximum particle size 50 µm
Pressurizing fluid	If sealing air is present, compressed air quality to ISO 8573- 1:2010 [7:4:4]
Max. coolant pressure	See dimensioned drawing
Ambient temperature	+5 °C to +50 °C
Humidity	≤ 75%
Weight	Use a suitable balance to measure

3.5 Coolant supply

3.5.1 Product with external coolant supply

In this version of the product the coolant is carried from the outside to the cutting edge or the workpiece via a spray tube or a ball spray nozzle.

3.5.2 Product with external and internal coolant supply



NOTICE

Material damage from unsuitable cooling lubricant or cooling lubricant with wrong particle size

Unsuitable cooling lubricant or cooling lubricant with a particle size larger than 50 µm can cause excessive wear and/or damage to the internal seals.

- Only use water-mixed cooling lubricant.
- The particle size of the cooling lubricant must be smaller than 50 µm. Install a filter system for the cooling lubricant, if the machine does not have one.

1. If using the internal coolant supply, make sure that coolant flow is always ensured.
2. Only use products with external coolant supply for the machining of gray cast iron, graphite, glass, and plastics.
3. Refer to the applicable pxn diagram for the product.
4. Clarify operating conditions outside the defined range in the pxn diagram with the manufacturer.

Each pxn diagram is clearly labeled (e.g. D 00 003). Which diagram applies to the respective product is stated on the dimensioned drawing.

3.5.2.1 Switching from internal to external coolant supply

Where fixed toolholders are used, setscrews can be used to switch between internal and external coolant supply. Refer to the dimensioned drawing to determine which setscrew is provided for this.

External coolant supply

1. Screwing in the setscrew
2. Remove the screw.

Internal coolant supply

1. Unscrew the setscrew until it is flush with the outside of the housing.
2. Screw in the screw.

Internal and external coolant supply combined

1. Unscrew the setscrew.
2. Remove the screw.

If stated on the dimensioned drawing, the cap can be moved if necessary, and therefore the boring bar can be inserted on the opposite side. In this case, the coolant supply must be switched over:

1. Set the setscrew at the back of the boring bar to internal coolant supply.
2. Set the other setscrew accordingly to external coolant supply.

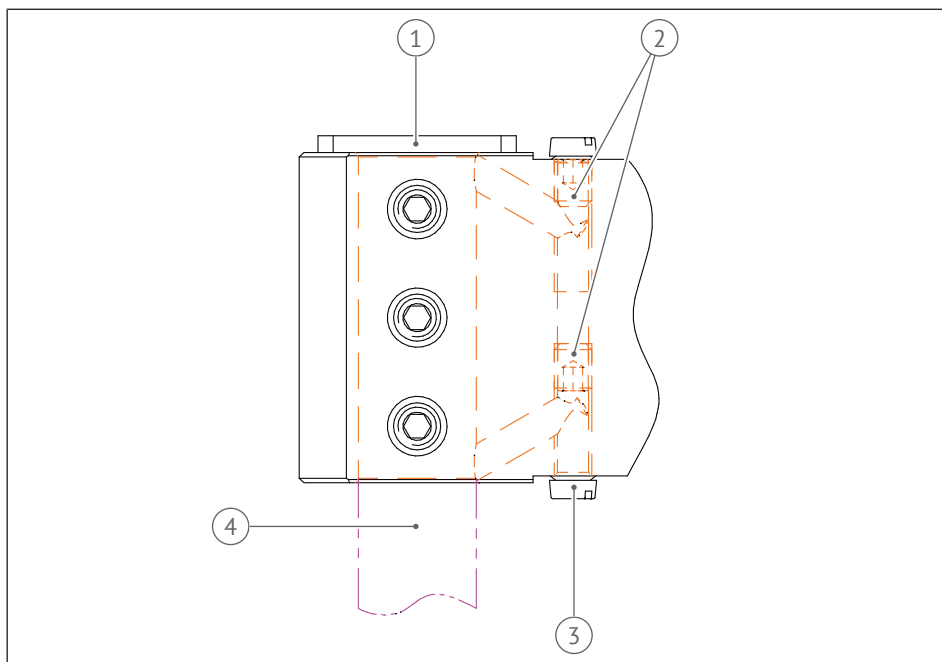

Fig. 4: Version with fixed toolholder

1	Cap	2	Setscrew
3	Screw	4	Boring bar

In case of multiple holders with internal coolant supply, turning tools must be clamped in all positions so that the coolant supply functions correctly. The two marks next to the groove indicate the area in which the coolant is transferred to the turning tool.

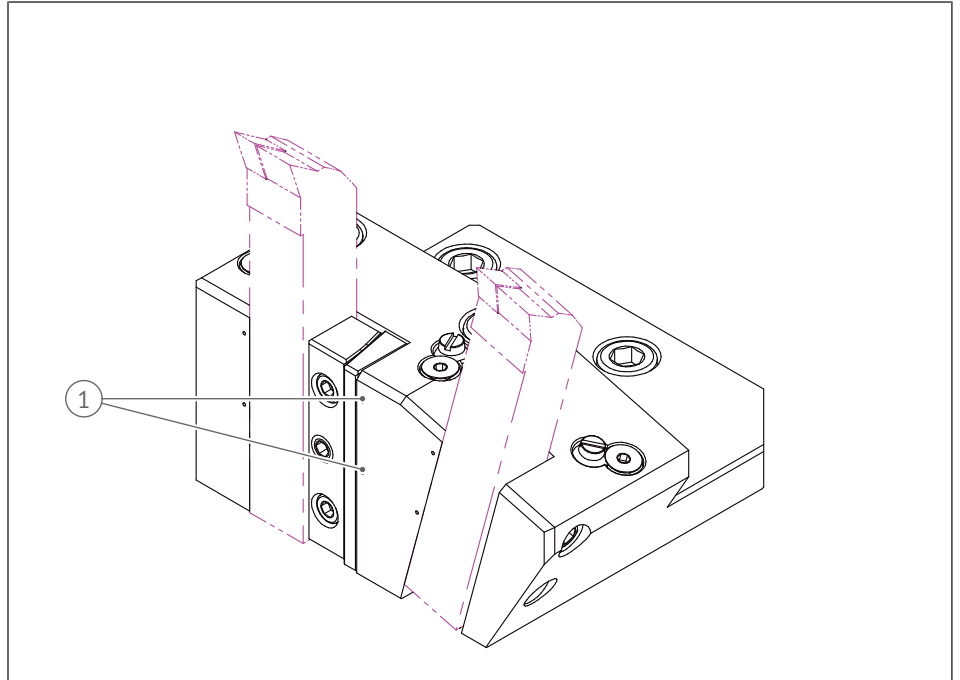

Fig. 5: Version with fixed toolholder/multiple toolholder

1	Coolant transfer, turning tool		
---	--------------------------------	--	--

4 Transport, handling and storage

4.1 Transport method



⚠ WARNING

Risk of injury from improper transport

Improper behavior during transport can cause the product to pose risks, which can lead to severe injuries and substantial damage to property.

- Transport with an appropriate means of transport.
- Secure the product against falling during transport and handling.
- Do not step under overhead loads.
- Only lift products heavier than 20 kg with lifting gear and note the center of gravity of the product.
- Observe the country-specific accident prevention regulations and the general safety instructions.
- Comply with all provisions of labor safety law.

4.2 Unpacking

The product is sent in a package. The package contains the following:

- Product
- Fastenings for mounting the product in the machine
- Packaging fillers for safe transport
- Operating tool

A corrosion inhibitor has been applied on the product.

1. Open the package and remove the product.
2. Position the product on a nonslip surface to secure it against falling.

Keep the package and the packaging fillers so that you can safely return the product if necessary.

4.3 Storage

- Keep the product and its accessories in a clean and dry environment.
- Protect the surfaces of the product from dirt and rust, for example, with a corrosion inhibitor.
- Protect the tool interface with a suitable cover.
- Before placing it in storage and during storage, turn all movable parts of the product one a month to avoid contact corrosion in the bearings and sticking of the seals, etc.

5 Assembly and commissioning



⚠ WARNING

Unexpected movement due to energy supply

If the energy supply is switched on or there is still residual energy in the system, components can move unexpectedly and cause severe injuries.

- Switch off the energy supply, make sure that there is no longer any residual energy present and secure against reconnection.
- Carry out maintenance, modification, and attachment work outside the danger zone determined by the movement area.



⚠ WARNING

Risk of injury from ejected parts

During operation, ejected objects can cause severe injuries and even death. Where products have a large mass and/or projecting length, it is possible for the system to reach its natural frequency, and thus damage the bearing. The machining tool or parts of it can be ejected with high kinetic energy.

- Secure the danger zone.
- Do not enter the danger zone during operation.
- Make sure that the product and accessories are clamped properly.
- Always clamp/chuck tools as short as possible.



⚠ CAUTION

Risk of injury from heated product

Increased temperatures can occur during operation. Contact with the product can cause burns.

- Wait until the product has cooled.
- Keep to the allowable on-time.
- Wear suitable protective gloves.



⚠ CAUTION

Cutting, grazing, or knocking against sharp corners and edges, and rough surfaces

When changing cutting tools, people can cut, graze themselves or knock against sharp corners and edges.

- Work in a safety-conscious and be fully aware of the dangers.
- Only change cutting tools outside the machine tool.
- Before handling the cutting tool, remove or cover it together with the tool unit.
- Wear suitable personal protective equipment.

5.1 Modification

Modifications, changes, and rework, for example, additional threads, holes, safety devices, can have a negative effect on function or safety, or cause damage to the product.

Carry out structural changes only with the written approval of heimatec.

5.2 Mounting in the machine

Before mounting Note the following points:

1. Remove any existing attachment elements (eyes, lugs) for transport.
2. Check whether the product's drive matches the machine toolholder's coupling.
3. Examine the product for damage. Do not use the product if it is clearly damaged.
4. Note any interfering contours – taking into consideration the planned machining tool – and the maximum weights predetermined by the toolholder. Refer to the operating manual of the toolholder or the machine manufacturer.
5. Check the parallel shank of the product and any O-rings fitted for presence, correct fit and damage.
6. Make sure that the contact surfaces of the product and the machine's toolholder are clean and free from chips and coolant residues. Do not use compressed air for cleaning.
7. Check whether the product has to be aligned to ensure correct coolant transfer from the toolholder to the product.

5.2.1 VDI interface

1. Insert the toolholder's water stopper pin into the coolant hole of the product.
 2. Position the contact surface of the product on the contact surface of the toolholder.
 - ⇒ The VDI product is correctly positioned on the toolholder.
 - ⇒ The toothed side of the shank automatically faces the toothed thrust piece of the toolholder.
 3. Tighten the VDI clamping bolt. Refer to the data sheet of the respective machine manufacturer for the tightening torque of the VDI clamping bolt.
- ➔ The product is mounted.

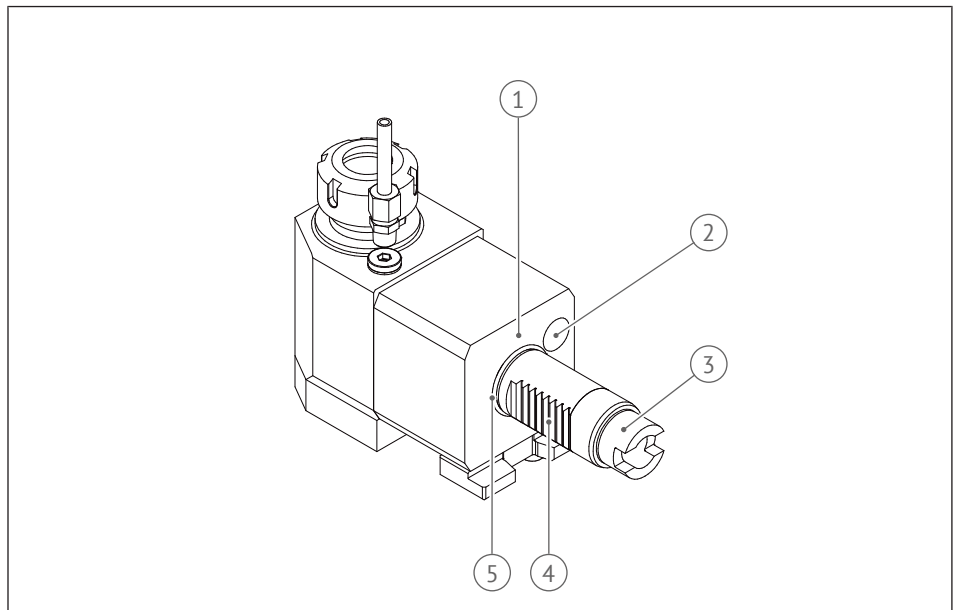

Fig. 6: VDI interface

1	Contact surface	2	Coolant hole
3	Drive	4	toothed shank side
5	O-rings		

5.2.2 BMT interface variants



NOTICE

Material damage caused by disregard of the specified tightening torques

Disregard of the specified tightening torques when tightening screws and bolts can cause damage.

- Comply with the recommended tightening torques (see Recommended tightening torques [▶ 13] section).
- Use a torque wrench.

5.2.2.1 Fastenings, fastening screws

In this version, the product is fixed onto the toolholder by four fastening screws (mostly cylinder head screws).

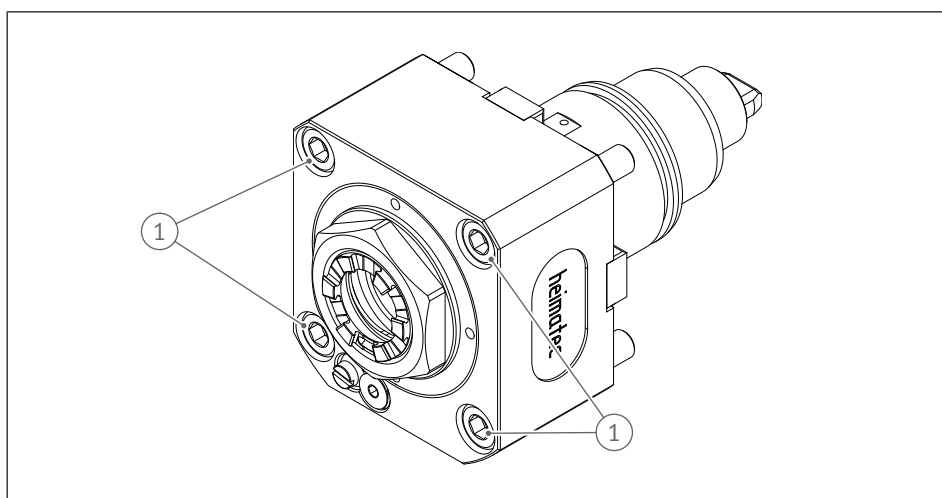

Fig. 7: Fastenings, fastening screws

1	Fastening screws		
---	------------------	--	--

5.2.2.2 Fastening, special screws

1. Screw the special screws into the threaded holes in the toolholder and tighten with the corresponding torque.
 2. Press the product onto the contact surface of the toolholder.
 3. Tighten the side fastening screws.
- ➡ The product is mounted.

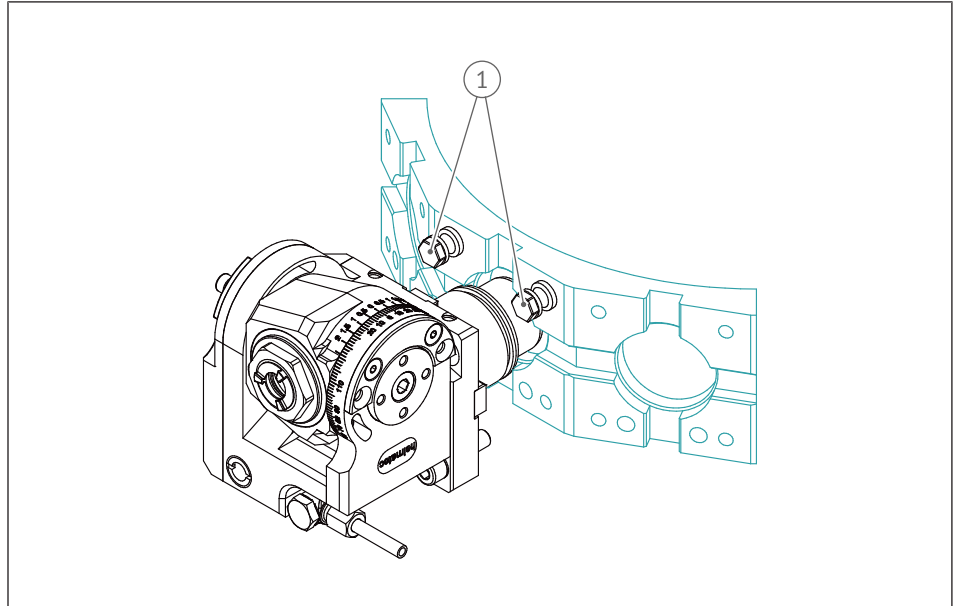

Fig. 8: Fastening, special screws

1	Special screws		
---	----------------	--	--

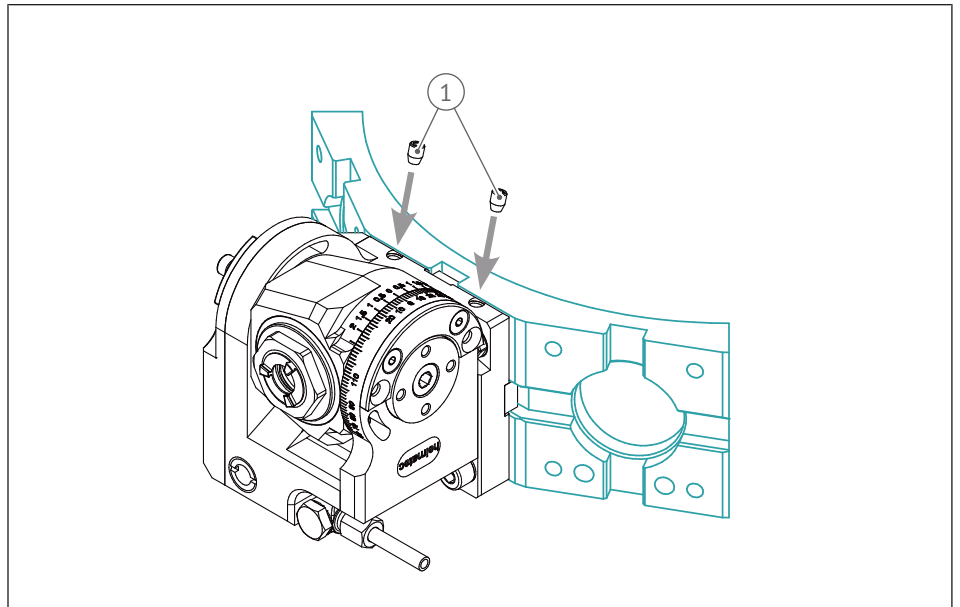

Fig. 9: Fastenings, special screws (fastening screws)

1	Fastening screws		
---	------------------	--	--

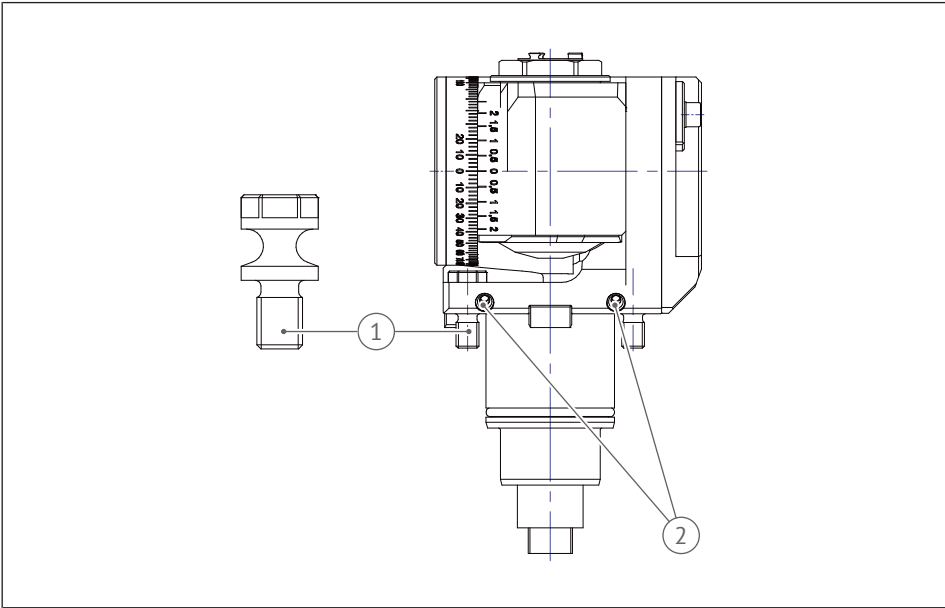

Fig. 10: Fastening, special screws overview

1	Special screws	2	Fastening screws
---	----------------	---	------------------

5.2.2.3 Fastening, adapter plate and fastening screws

1. Use the mounting aid to fit the plate on the toolholder.
 2. Use the fastening screws to tighten the plate uniformly.
 3. Remove the mounting aid.
 4. Insert the product through the plate into the toolholder.
 5. Tighten the screws.
- ➔ The product is mounted.

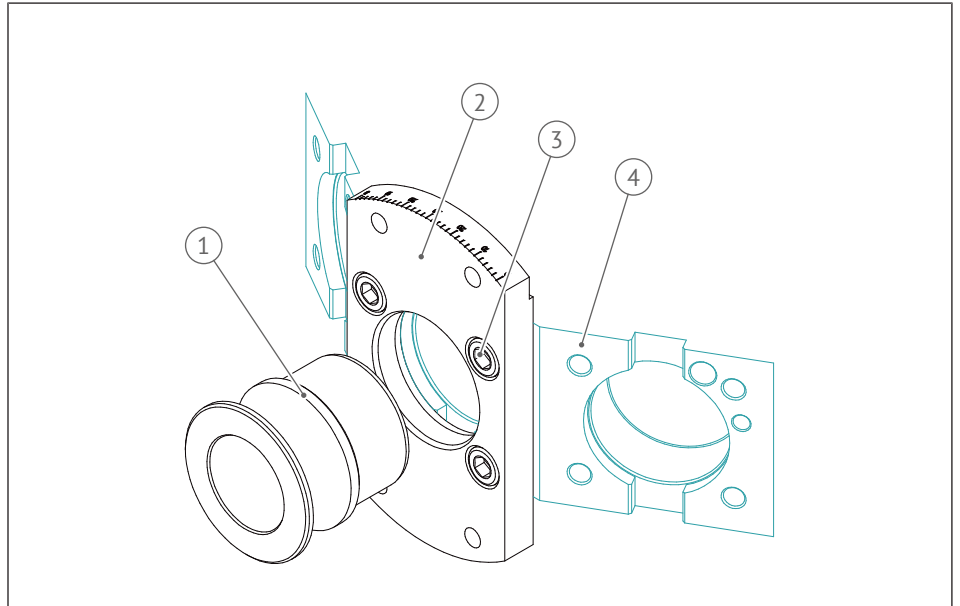

Fig. 11: Adapter plate fastening and fastening screws (mounting aid)

1	Mounting aid	2	Plate
3	Fastening screws	4	Toolholder

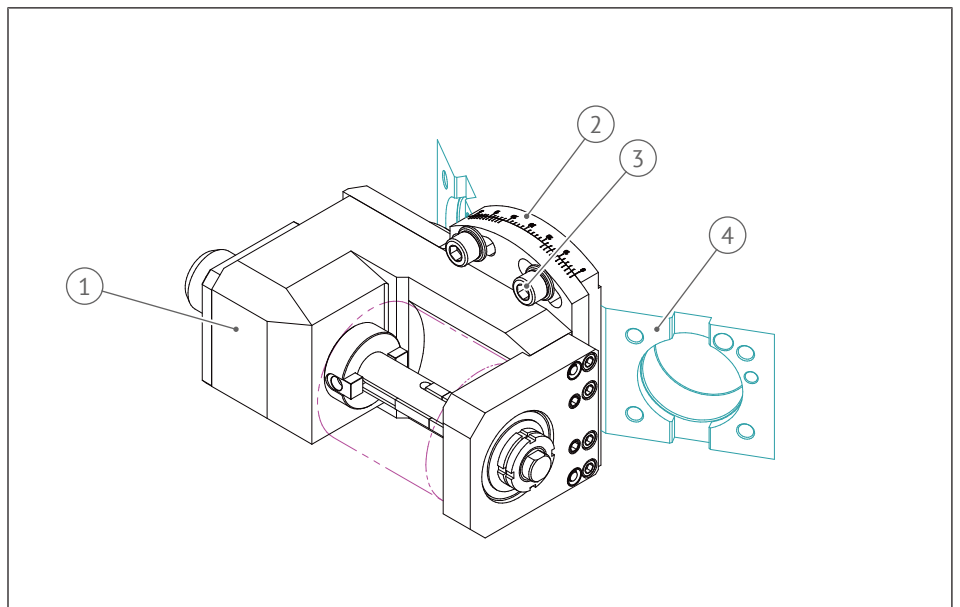

Fig. 12: Fastening, adapter plate and fastening screws

1	Product	2	Plate
3	Screws	4	Toolholder

5.2.2.4 Taper gib fastening

1. Fit the plate between the toolholder and the product.
 2. Insert the product into the toolholder.
 3. Position the taper gib/clip according to the active areas.
 4. Tighten the side fastening screws.
- ➔ The product is mounted.

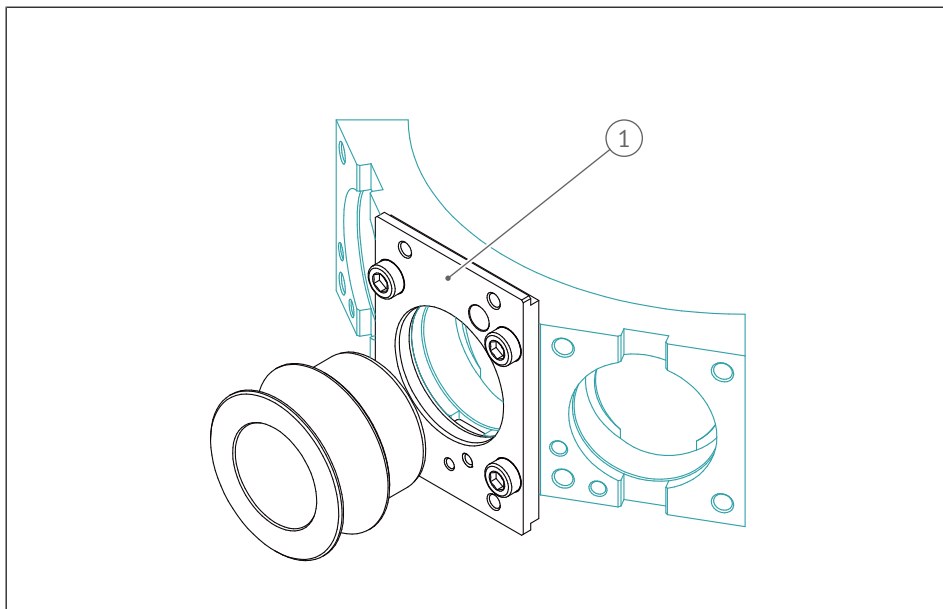

Fig. 13: Fastening, taper gib (plate)

1	Plate		
---	-------	--	--

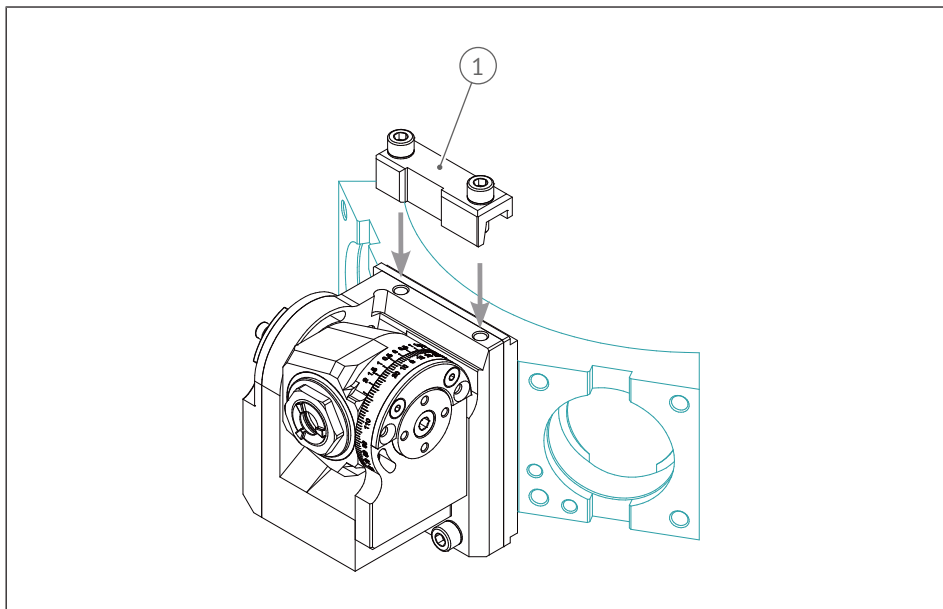

Fig. 14: Fastening, taper gib (taper gib/clip)

1	Taper gib/clip		
---	----------------	--	--

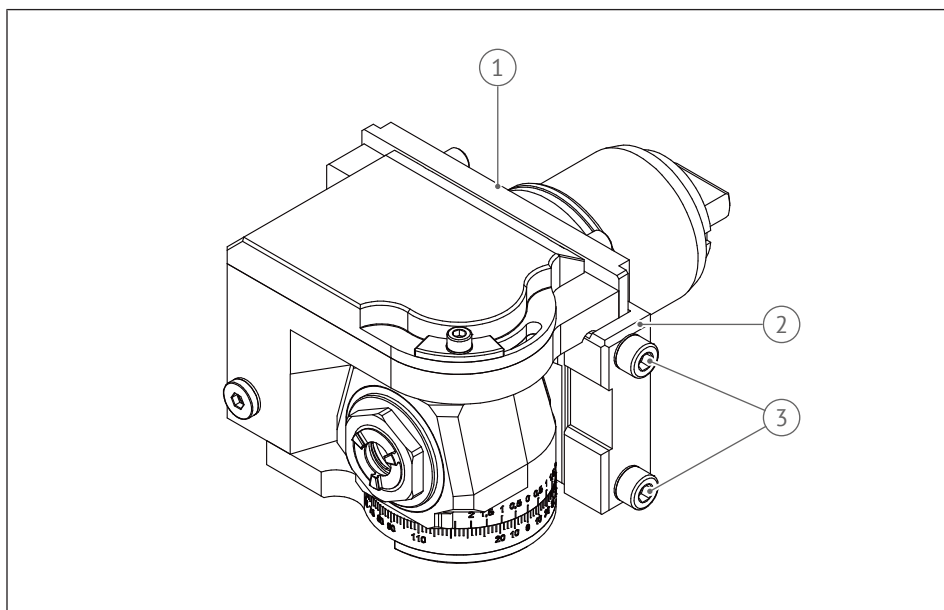

Fig. 15: Taper gib fastening

1	Plate	2	Taper gib/clamp
3	Fastening screws		

Additional note the following:

- Combinations of the various fastening systems can also occur.
- If provided, fit the enclosed lock washers under the screw head of the fastening screws to prevent the screws from unscrewing.
- Do not operate the toolholder without inserted tool insert tightened according to the instructions (see Mounting the cutting tool/accessories).

5.3 Alignment of the product

Alignment is necessary for angular products and products with offset axis. If the alignment of the product is not ensured on the machine side, it must be carried out manually. Manual alignment is possible by different fixings.

5.3.1 Permanent fixing

Type A

The fixing bar is permanently attached to the product. Since no handling is required, the screws are sealed.

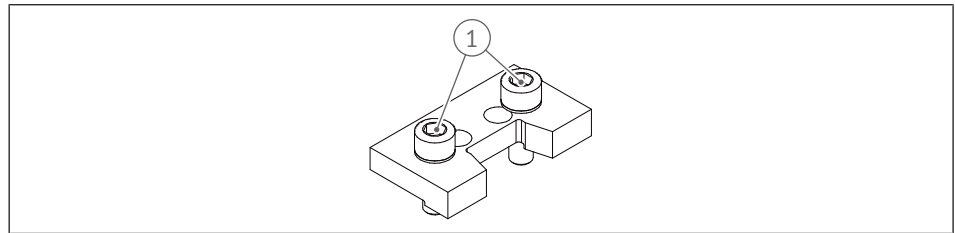

Fig. 16: Type A

1	Screws		
---	--------	--	--

Type B

✓ Handling the screws is required.

1. Undo the screws before mounting the product.
2. Insert the product into the toolholder.
3. Lightly position the product's fastening so that the product is positioned against the contact surface but can still be turned.
4. Retighten the screws.
5. Do not tighten the product fastening until after the gib has been tightened on the toolholder.

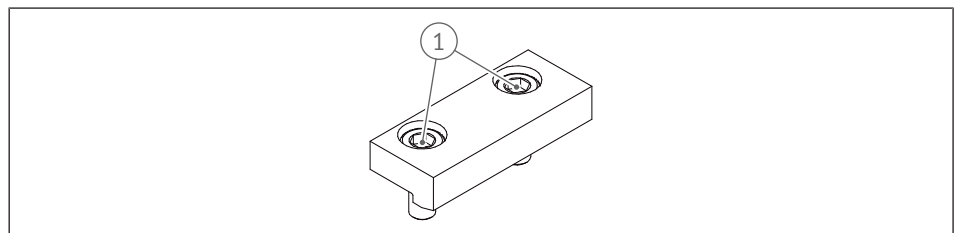

Fig. 17: Type B

1	Screws		
---	--------	--	--

5.3.2 Adjustable fixing

- ✓ The fixing is tightly attached to the product.
 1. Insert the product into the toolholder.
 2. Lightly position the product's fastening so that the product is positioned against the contact surface, but can still be turned.
 - ⇒ The radial position of the product can now be changed using the adjustment screws.
 3. Use the adjustment screws to set the correct location of the product on the toolholder position.
 4. Use the nuts or screws, or setscrews to secure the adjustment screws against unscrewing and tighten.
 5. Retighten the product's fastenings.
- ➔ The correct location of the product is set.

If the correct location of the product is set on a toolholder position, only one adjustment screw is undone to remove the product. For renewed insertion of the product on the same position, the same adjustment screw is tightened and locked, and the product is aligned correctly.

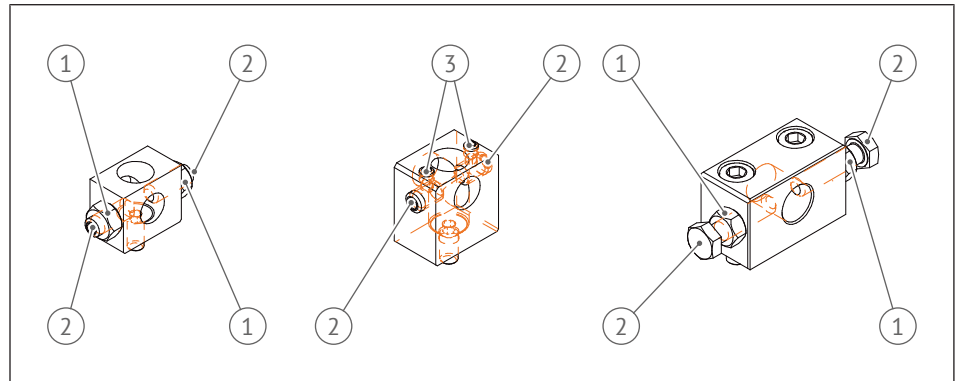

Fig. 18: Adjustable fixing

1	Nut/bolt	2	Adjustment screw
3	Setscrew		

5.3.3 Preadjustable fixing

- ✓ The fixings are preset once.
 1. Use the adjustment screws to set the correct location of the product on the toolholder position.
 2. Use the nuts or screws, or setscrews to secure the adjustment screws against unscrewing and tighten.
 3. Undo the screws to mount the product on the toolholder.
 4. Insert the product into the toolholder.
 5. Lightly position the product's fastening so that the product is positioned against the contact surface, but can still be turned.
 6. Retighten the screws.
 7. Retighten the product's fastenings.

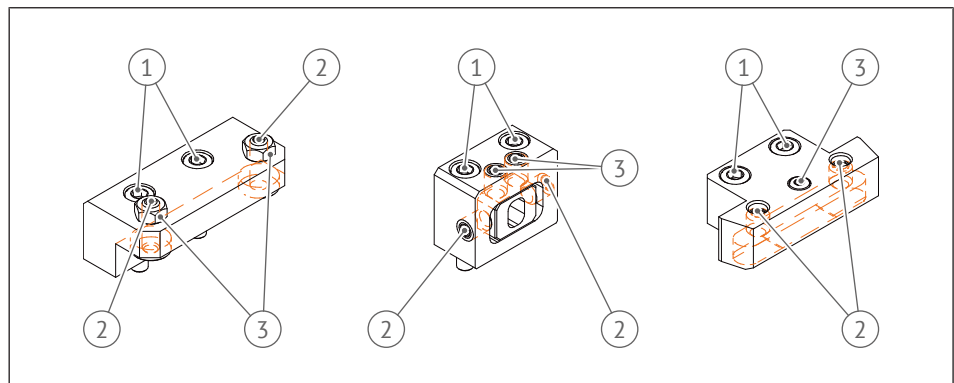

Fig. 19: Preadjustable fixing

1	Screw	2	Adjustment screw
3	Nut/bolt		

5.4 Mounting the cutting tool/accessories

5.4.1 Collet chuck holder

Mount the collet chuck holder as follows:

1. Insert the collet chuck into the clamping nut at an angle until it audibly latches into position.
2. Insert the cutting tool into the collet chuck.
3. Tighten the clamping nut; make sure that you hold the spindle in position.

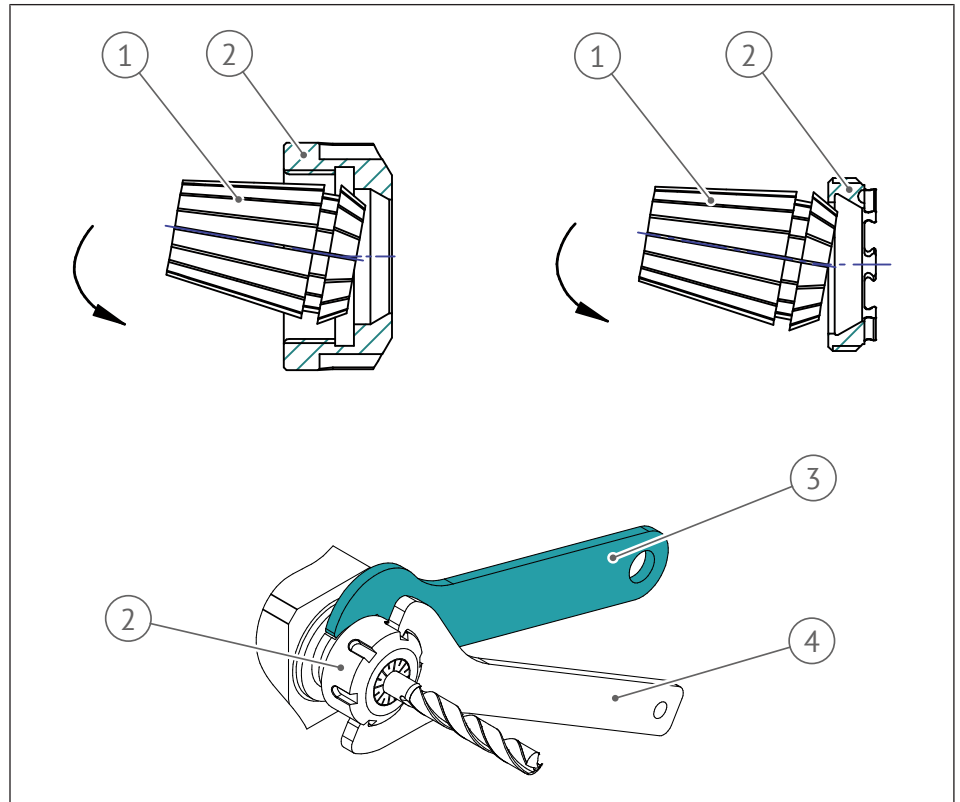

Fig. 20: Collet chuck holder

1	Collet chuck	2	Clamping nut
3	Wrench for holding the spindle in position	4	Wrench for tightening the clamping nut

5.4.2 Fitting and dismantling DS sealing washers

5.4.2.1 Type DS/ER

Fit the sealing washer as follows:

1. Insert the sealing washer in the corresponding matching clamping nut.
2. Push the sealing washer to the front until it audibly latches into position.

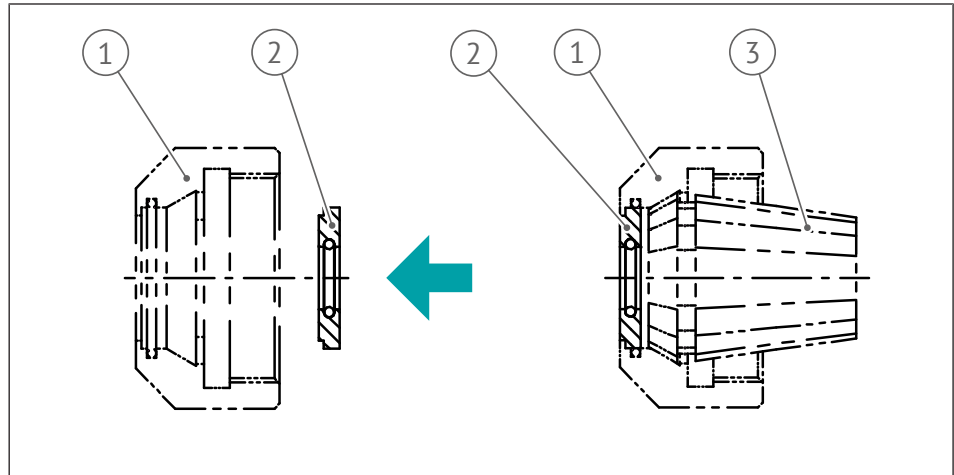

Fig. 21: DS/ER version: Fitting the sealing washer

1	Clamping nut	2	Sealing washer
3	Collet chuck		

Dismantle the sealing washer as follows:

1. Push away the sealing washer from the outside.
⇒ The sealing washer detaches itself from the anchoring.
2. Remove the sealing washer.

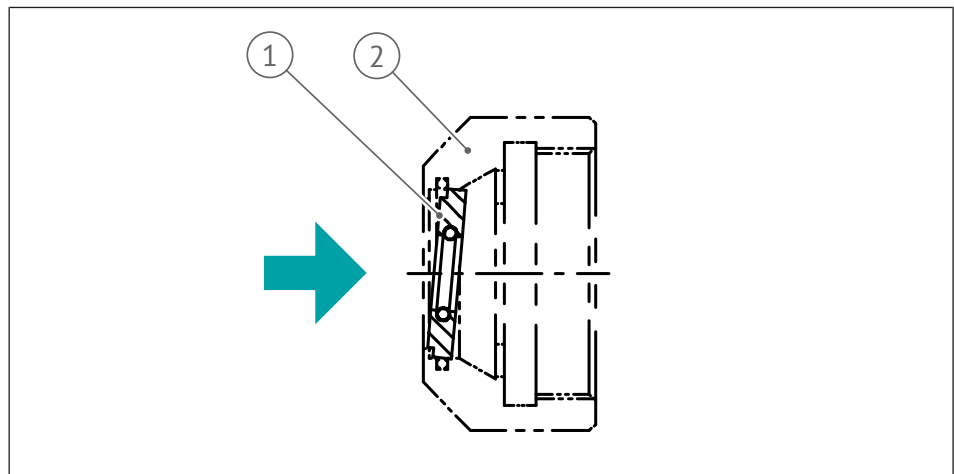

Fig. 22: DS/ER version: Dismantling the sealing washer

1	Sealing washer	2	Clamping nut
---	----------------	---	--------------

5.4.2.2 heimatec-DS type

Fit the sealing washer as follows:

1. Position the sealing washer on the collet chuck.
2. Fit the sealing washer and the collet chuck together in the spindle holder.

Dismantle the sealing washer as follows:

- The sealing washer is dismantled automatically when the cutting tool is pulled out.

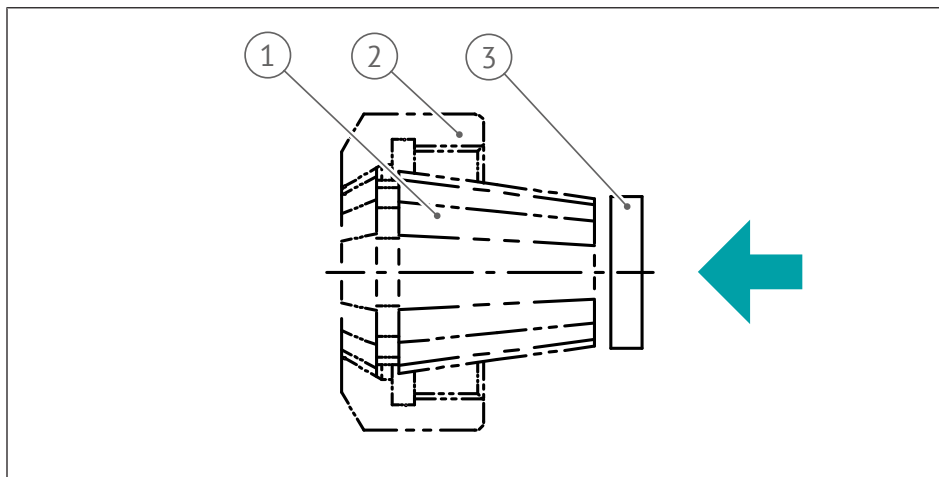

Fig. 23: heimatec-DS type

1	Collet chuck	2	Clamping nut
3	Sealing washer		

5.4.3 u-tec® UT

5.4.3.1 Interchangeable inserts with ejector collar

Fit the u-tec® insert as follows:

1. Unscrew the clamping nut and keep it.
2. Insert the u-tec® insert and check for correct fit.
3. Use the special nut to tighten the u-tec® insert. Always hold in position at the spindle.

Refer to the Recommended tightening torques [▶ 13] section for tightening torques.

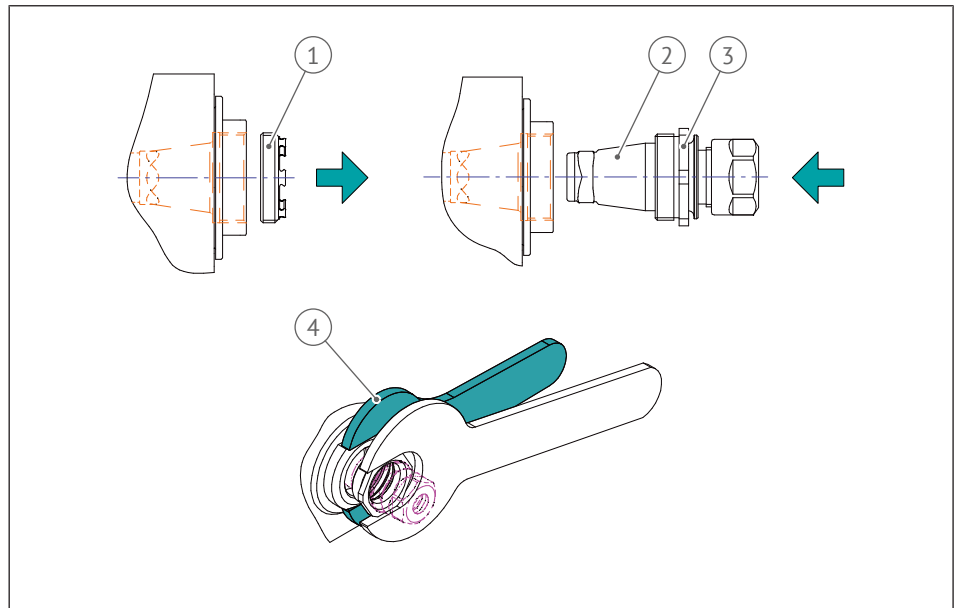

Fig. 24: Fitting the u-tec® insert

1	Clamping nut	2	u-tec® insert
3	Special nut	4	Wrench for holding in position

Dismantle the u-tec® insert as follows:

- Unscrew the nut.

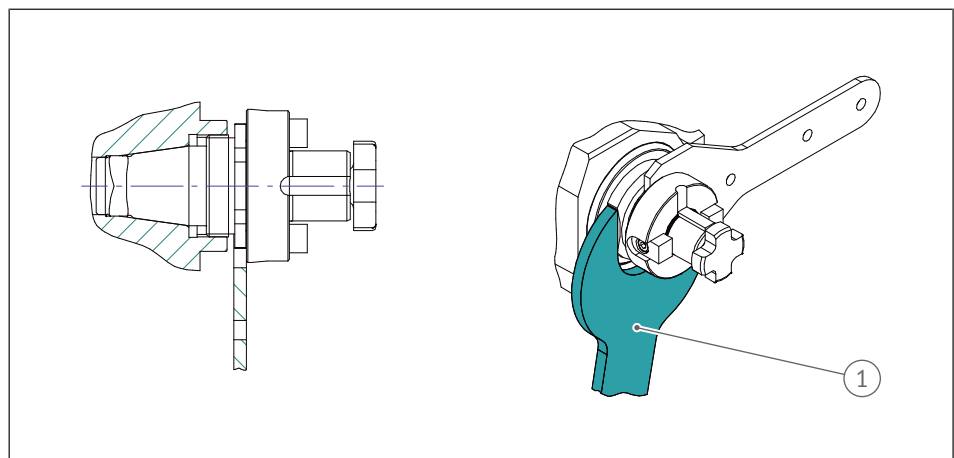

Fig. 25: Interchangeable inserts with ejector collar

1	Wrench for holding in position		
---	--------------------------------	--	--

5.4.3.2 Interchangeable inserts without ejector collar

Fit the u-tec® insert as follows:

1. Unscrew the clamping nut and keep it.
2. Insert the u-tec® insert and check for correct fit.
3. Use the special nut to tighten the u-tec® insert. Always hold in position at the spindle.

Refer to the Recommended tightening torques [▶ 13] section for tightening torques.

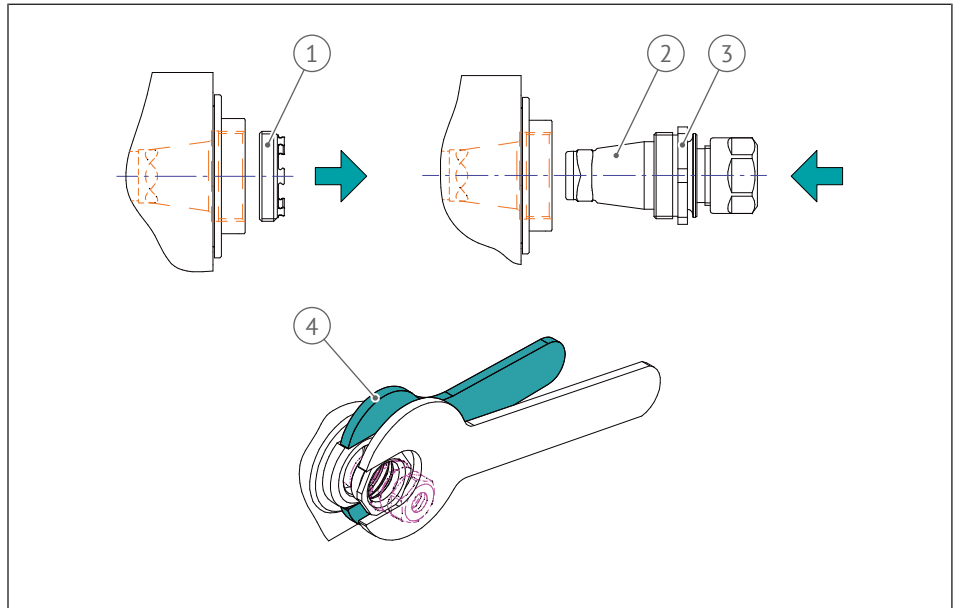

Fig. 26: Fitting the u-tec® insert

1	Clamping nut	2	u-tec® insert
3	Special nut	4	Wrench for holding in position

Dismantle the u-tec® insert as follows:

1. Use special dismantling wrench.
2. Undo the nut.
3. Push out the insert.

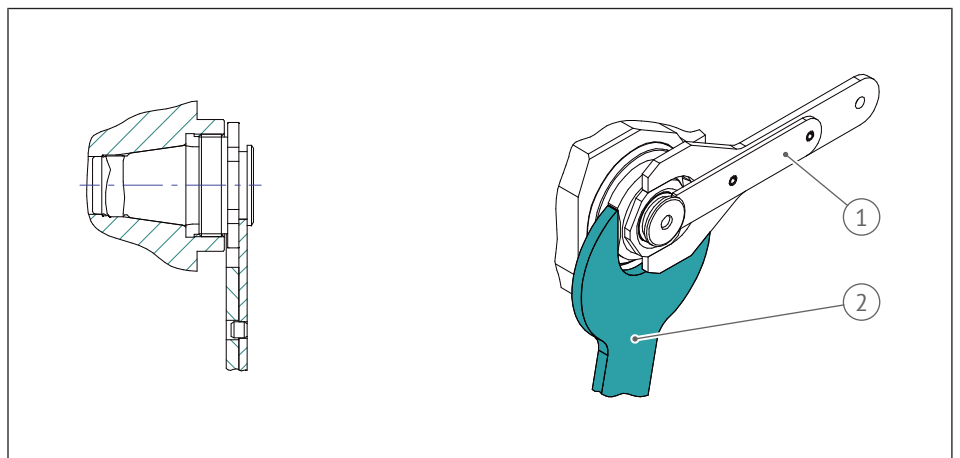

Fig. 27: Interchangeable inserts without ejector collar

1	special dismantling wrench	2	Wrench for holding in position
---	----------------------------	---	--------------------------------

5.4.4 HT/UT mounting block

It is possible to fit the cutting tools in different interchangeable inserts. To do so, proceed as follows:

1. Securely set up the mounting block, preferably by screwing it tight on the workbench or by secure clamping in a vise.
2. The attachment is adjustable and can be positioned in 30° increments.
3. The relocatable locking pin holds the holder/interchangeable bush and can be operated on the left or right.

Other holders/interchangeable bushes for tool inserts are optionally available in different sizes and types.

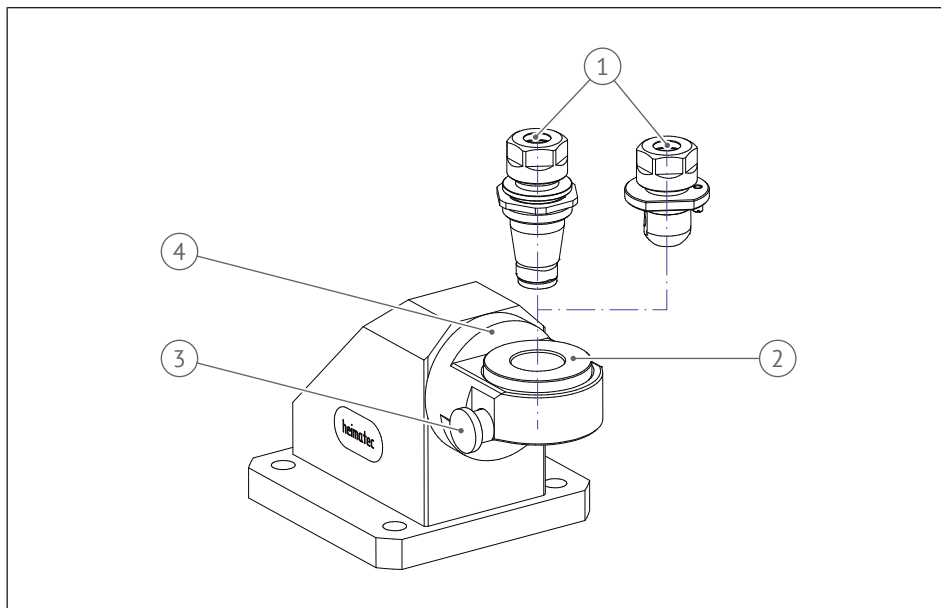

Fig. 28: HT/UT mounting block

1	Interchangeable inserts	2	Holder/interchangeable bush
3	Locking pin	4	Attachment

5.4.5 icosen® sensor unit



⚠ DANGER

Risk of injury from electromagnetic fields

The product generates electromagnetic fields, which under certain circumstances can interact with medical implants. There is therefore a risk of serious or fatal injury.

- Before using the product, seek medical advice if you have a medical implant.



⚠ WARNING

Risk of injury from electric shock or fire

When dismantling the sensor unit, there is a risk of electric shock or fire.

- Do not dismantle the sensor unit.

5.4.5.1 Commissioning

On delivery, the sensor is inactive. Choose one of the two activities to activate it:

- Briefly drive the product with at least 120 rpm.
- or
- Hold a magnet (maximum 8 mm × 8 mm × 8 mm) on the surface of the sensor until the LED lights up.

5.4.5.2 Operation

Use of icosen® requires a PC with a Bluetooth adapter from heimatec. The sensor is operated via PC software.

The sensor unit is energy-independent in power-driven tool units and does not necessarily have to be charged. However, if the battery is empty, it can be recharged. To do so, plug the charging cable into the charging contact. Since a magnet is installed in the charging point, proceed in the following order:

1. Connect the charging cable to the sensors.
2. Connect the charging cable to the power supply system.

5.4.5.3 Requirements

- heimatec Bluetooth adapter in the PC
- heimatec PC software
- Current firmware on the sensor unit

The current version of the PC software and sensor firmware, and the instructions for their installation and operation can be downloaded from www.heimatec.com.

5.4.5.4 Technical data

Parameter	Value
Supply voltage	3.7 V lithium battery
Radio frequency	2.4 GHz
Maximum radio power	+5 dBm
Approval	Testing of radio properties according to ETSI EN 300 328 V2.2.2
BLE range	Maximum 7 m

6 Maintenance



WARNING

Unexpected movement due to energy supply

If the energy supply is switched on or there is still residual energy in the system, components can move unexpectedly and cause severe injuries.

- Switch off the energy supply, make sure that there is no longer any residual energy present and secure against reconnection.
- Carry out maintenance, modification, and attachment work outside the danger zone determined by the movement area.

6.1 Cleaning



NOTICE

Material damage from incorrect cleaning

Cleaning with compressed air can cause material damage.

- Only use clean cloths for cleaning.

Cleaning Clean the product every 30 operating hours at the latest to maintain the high quality and accuracy.

Testing the function Check the function of the product once a week:

- ✓ The tool is removed.
- Visually inspect and clean the tool holder and the area around the tool holder.

7 Troubleshooting and repair

7.1 Action in case of faults

Note the following if faults occur:

- Remove the product from operation immediately and report the fault to the responsible positions/persons.
- Have the faults corrected by personnel trained for this purpose.
- Do not restart the product until the fault has been removed.
- After a fault, check that the product still functions and no enhanced hazards have resulted.
- If you are unable to correct the fault, contact the manufacturer (service@heimatec.com) and provide the following details:
 - Order/item number
 - heimatec serial number
 - Brief details of the damage features

7.2 Repair



NOTICE

Material damage from non-approved replacement parts

Use of replacement parts that have not been approved by the manufacturer can cause hazards for the personnel and product damage or malfunctions.

- Only use original replacement parts and replacement parts approved by the manufacturer.
- Only heimatec's own service centers and authorized service workshops may repair these products (service@heimatec.com).

8 Disposal

Improper disposal can cause the product to pose dangers, which can lead to severe injuries, substantial damage to property and environmental damage.

- Recycle or properly dispose of the components of the product according to the local regulations
- Do not dispose of the product in normal household waste
- Contact heimatec in case of any uncertainties



heimatec[®]

heimatec GmbH
Präzisionswerkzeuge
Carl-Benz-Str. 4
77871 Renchen
Germany
T: +49 7843 9466 0
F: +49 7843 9466 66
info@heimatec.com
www.heimatec.com

The contact details of our worldwide trading partners can be found on our website: www.heimatec.com/handelspartner