

Mori Seiki

ZL 153

MC/SMC/Y/SY



High-tech from heimatec - heimatec - Tools and systems for productive turning and milling

heimatec belongs to the international technology and quality leaders for precision tools and specializes in the development and production of high-precision static and live tools for all CNC lathes, CNC turn-/mill machines and CNC machining centers.

The range of products* spans from static BMT and VDI tool holders, live tools up to highly complex customer-specific individual solutions. heimatec, headquartered in Renchen, has a own subsidiary in Asia and India and numerous representatives as well as trading partners all over the world.

*OUR PRODCUTS

Static tool holders

Live tool units

Precision tools

Tools for turning and machining centres

Tools for swiss type lathes

Tool changing and uick-change systems

Tool systems for gear production

Digital tool management

This catalogue, including all its parts, is protected by copyright. Any use outside the restricted limitations of the Copyright Act without the consent of heimatec is inadmissible and liable to prosecution. This applies in particular to duplication, translation, microfilming and storage and processing in electronic systems.

heimatec GmbH reserves the right to make technical changes at any time without giving prior notice. This applies in particular to adjustments at any time to meet new or changed international standards, or in case of further developments of our products or manufacturing processes.

The current version of our General Terms and Conditions can be found on our website.

| Part-# | Name | |
|---------------------|--|--------------------------------|
| 8 010 35 000 | Axial drilling and milling head ER 25 | |
| | Weight [kg]: | 3.820 |
| | Tool drive: | Flat (~DIN 1809) |
| | Shank size [mm]: | 32.00 |
| | Shank type: | BMT |
| | Tool adaption: | ER 25 |
| | Gear ratio [i]: | 1:1 |
| | Torque max [Nm]: | 50 |
| | Rotation max [1/min]: | 6000 |
| | Rotating direction: | same |
| | Coolant: | EXT |
| | Please note: | stronger bearing |
| 8 010 35 001 | Axial drilling and milling head ER 25 IC | |
| | Weight [kg]: | 3.820 |
| | Tool drive: | Flat (~DIN 1809) |
| | Shank size [mm]: | 32.00 |
| | Shank type: | BMT |
| | Tool adaption: | ER 25 |
| | Gear ratio [i]: | 1:1 |
| | Torque max [Nm]: | 50 |
| | Rotation max [1/min]: | 6000 |
| | Rotating direction: | same |
| | Coolant: | IC/Ext |
| | Pressure max [bar]: | 25 |
| | Please note: | stronger bearing |
| 8 013 34 000 | Axial drilling and milling head ER 16 AS | |
| | Tool drive: | Flat (~DIN 1809) |
| | Shank size [mm]: | 32.00 |
| | Shank type: | BMT |
| | Tool adaption: | ER 16 A |
| | Gear ratio [i]: | 1:2 |
| | Torque max [Nm]: | 6 |
| | Rotation max [1/min]: | 8000 |
| | Rotating direction: | same |
| | Coolant: | EXT |
| 8 013 34 002 | Axial drilling and milling head ER 16 AX UT | |
| | Tool drive: | Flat (~DIN 1809) |
| | Shank size [mm]: | 32.00 |
| | Shank type: | BMT |
| | Tool adaption: | ER 16 A |
| | Gear ratio [i]: | 1:4 |
| | Torque max [Nm]: | 3 |
| | Rotation max [1/min]: | 16000 |
| | Rotating direction: | same |
| | Coolant: | EXT |
| 8 030 35 002 | Radial drilling and milling head ER 25 | |
| | Weight [kg]: | 6.900 |
| | Employment for: | Main spindle (front operation) |
| | Tool drive: | Flat (~DIN 1809) |
| | Shank size [mm]: | 32.00 |
| | Shank type: | BMT |
| | Tool adaption: | ER 25 |
| | Gear ratio [i]: | 1:1 |
| | Torque max [Nm]: | 16 |

| Part-# | Name | |
|---------------------|--|---|
| | Rotation max [1/min]: | 6000 |
| | Rotating direction: | opposite |
| | Coolant: | EXT |
| | Please note: | Machine: Mori Seiki, SL 154 MC/SMC/Y/SY |
| | Center distance [mm]: | 67,5 |
| 8 030 35 003 | Radial drilling and milling head ER 25 | |
| | Weight [kg]: | 7.300 |
| | Employment for: | Sub spindle |
| | Tool drive: | Flat (~DIN 1809) |
| | Shank size [mm]: | 32.00 |
| | Shank type: | BMT |
| | Tool adaption: | ER 25 |
| | Gear ratio [i]: | 1:1 |
| | Torque max [Nm]: | 16 |
| | Rotation max [1/min]: | 6000 |
| | Rotating direction: | same |
| | Coolant: | EXT |
| | Center distance [mm]: | 67,5 |
| 8 030 35 006 | Radial drilling and milling head ER 25 IC | |
| | Employment for: | Main spindle (front operation) |
| | Tool drive: | Flat (~DIN 1809) |
| | Shank size [mm]: | 32.00 |
| | Shank type: | BMT |
| | Tool adaption: | ER 25 |
| | Gear ratio [i]: | 1:1 |
| | Torque max [Nm]: | 16 |
| | Rotation max [1/min]: | 6000 |
| | Rotating direction: | opposite |
| | Coolant: | IC/Ext |
| | Pressure max [bar]: | 140 |
| | Please note: | Machine: Mori Seiki, SL 154 MC/SMC/Y/SY |
| | Center distance [mm]: | 67,5 |
| 8 031 34 000 | Radial polygon head arbor 16 | |
| | Tool drive: | Flat (~DIN 1809) |
| | Shank size [mm]: | 32.00 |
| | Shank type: | BMT |
| | Tool adaption: | Arbor 16 |
| | Gear ratio [i]: | 1:1 |
| | Torque max [Nm]: | 16 |
| | Rotation max [1/min]: | 4000 |
| | Rotating direction: | opposite |
| | Coolant: | EXT |
| 8 039 35 000 | Radial drilling and milling head ER 25 | |
| | Weight [kg]: | 7.650 |
| | Version: | double spindle |
| | Tool drive: | Flat (~DIN 1809) |
| | Shank size [mm]: | 32.00 |
| | Shank type: | BMT |
| | Tool adaption: | ER 25 |
| | Gear ratio [i]: | 1:1 |
| | Torque max [Nm]: | 16 |
| | Rotation max [1/min]: | 6000 |
| | Rotating direction: | opposite |
| | Coolant: | EXT |

| Part-# | Name | |
|---------------------|---|-------------------------|
| | Center distance [mm]: | 67,5 |
| 8 040 34 001 | Universal head + 90°/-72° adj. ER16 | |
| | Weight [kg]: | 3.780 |
| | Tool drive: | Flat (~DIN 1809) |
| | Shank size [mm]: | 32.00 |
| | Shank type: | BMT |
| | Tool adaption: | ER 16 |
| | Gear ratio [i]: | 1:1 |
| | Torque max [Nm]: | 10 |
| | Rotation max [1/min]: | 5000 |
| | Rotating direction: | same |
| | Coolant: | EXT |
| | Please note: | Note swivel range |
| 8 040 34 004 | Universal head + 90°/-72° adj. ER20 | |
| | Weight [kg]: | 3.860 |
| | Version: | Special |
| | Tool drive: | Flat (~DIN 1809) |
| | Shank size [mm]: | 32.00 |
| | Shank type: | BMT |
| | Tool adaption: | ER 20 |
| | Gear ratio [i]: | 1:1 |
| | Torque max [Nm]: | 10 |
| | Rotation max [1/min]: | 5000 |
| | Rotating direction: | same |
| | Coolant: | EXT |
| | Please note: | Note swivel range |
| 8 202 10 015 | Basic holder longitudinal seat FN 12 | |
| | Weight [kg]: | 0.920 |
| | Notation: | 180° reversible |
| | Shank type: | BMT |
| | Machine adaption: | Centering key slot b 20 |
| | Tool adaption: | Interface FN 12 |
| | Coolant: | EXT |
| | Center distance [mm]: | 15,5 |
| 8 240 18 014 | Boring bar holder Ø 32 | |
| | Weight [kg]: | 2.340 |
| | Shank type: | BMT |
| | Machine adaption: | Centering key slot b 20 |
| | Tool adaption: | Ø 32 |
| | Coolant: | IC/Ext |
| | Center distance [mm]: | 35 |
| 8 240 18 015 | Boring bar holder Ø 32 | |
| | Weight [kg]: | 2.500 |
| | Shank type: | BMT |
| | Machine adaption: | Centering key slot b 20 |
| | Tool adaption: | Ø 32 |
| | Coolant: | IC/Ext |
| | Please note: | Special version |

Mori Seiki
ZL 153 MC/SMC/Y/SY

| Part-# | Name | |
|---------------------|---|-------------------------|
| 8 251 14 003 | Combi double turning holder sq. 20 | |
| | Weight [kg]: | 3.600 |
| | Employment for: | Main- and sub spindle |
| | Shank type: | BMT |
| | Machine adaption: | Centering key slot b 20 |
| | Tool adaption: | Sq. 20 |
| | | Sq. 20 |
| | | Sq. 20 |
| | | Sq. 20 |
| | Coolant: | EXT |
| 8 253 17 011 | Double boring bar holder Ø 25 | |
| | Weight [kg]: | 3.630 |
| | Shank type: | BMT |
| | Machine adaption: | Centering key slot b 20 |
| | Tool adaption: | Ø 25 |
| | | Ø 25 |
| | Coolant: | IC/Ext |
| | Center distance [mm]: | 35/75 |

heimatec.u-tec®

heimatec.com

Products / Tool change systems /
u-tec® Tool-changing system



versions see catalog



heimatec.easy-quick

heimatec.com

Products / Tool change systems /
easy-quick HT quick-changing system



versions see catalog



heimatec.Capto™

heimatec.com

Products / Tool change systems /
heimatec.Capto™ quick-changing system



versions see catalog

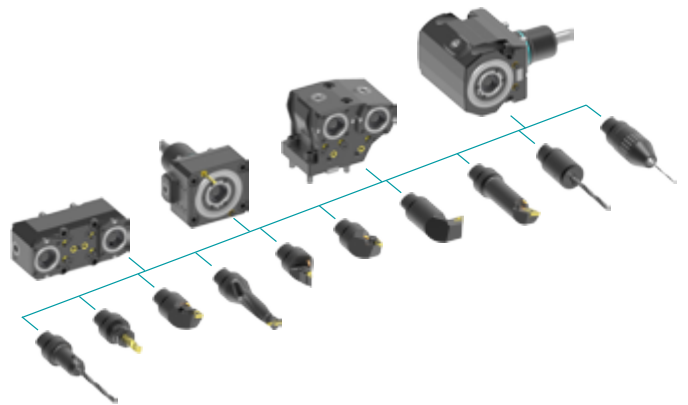

heimatec.accessories

heimatec.com

Products / Accessories



versions see catalog





● heimatec overseas branches

○ global representations of heimatec

heimatec[®]

heimatec GmbH
Präzisionswerkzeuge
Carl-Benz-Str. 4
77871 Renchen
Germany

T +49 7843 9466 0
www.heimatec.com
info@heimatec.com

Please find the contact details of our worldwide trading partners on our website:
<https://heimatec.com/business-partners>