

Goodway  
**GTX 2600 -  
16-Stat.**



# High-tech from heimatec - heimatec - Tools and systems for productive turning and milling

heimatec belongs to the international technology and quality leaders for precision tools and specializes in the development and production of high-precision static and live tools for all CNC lathes, CNC turn-/mill machines and CNC machining centers.

The range of products\* spans from static BMT and VDI tool holders, live tools up to highly complex customer-specific individual solutions. heimatec, headquartered in Renchen, has a own subsidiary in Asia and India and numerous representatives as well as trading partners all over the world.

## \*OUR PRODCUTS

Static tool holders

Live tool units

Precision tools

Tools for turning and machining centres

Tools for swiss type lathes

Tool changing and uick-change systems



Tool systems for gear production

Digital tool management



This catalogue, including all its parts, is protected by copyright. Any use outside the restricted limitations of the Copyright Act without the consent of heimatec is inadmissible and liable to prosecution. This applies in particular to duplication, translation, microfilming and storage and processing in electronic systems.

**heimatec GmbH** reserves the right to make technical changes at any time without giving prior notice. This applies in particular to adjustments at any time to meet new or changed international standards, or in case of further developments of our products or manufacturing processes.

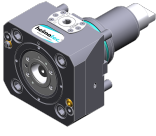
The current version of our General Terms and Conditions can be found on our website.

Part-#	Name	
<b>8 010 55 038</b>	<b>Axial drilling and milling head ER 25 AX UT IC</b>	
	Weight [kg]:	3.050
	Tool drive:	Flat (~DIN 1809)
	Shank size [mm]:	55.00
	Shank type:	BMT
	Tool adaption:	ER 25 A - u-tec
	Gear ratio [i]:	1:1
	Torque max [Nm]:	50
	Rotation max [1/min]:	6000
	Rotating direction:	same
	Coolant:	IC/Ext
	Pressure max [bar]:	25
	Please note:	Combi bearing
<b>8 010 55 039</b>	<b>Axial drilling and milling head ER 25 AX UT</b>	
	Notation:	180° reversible
	Tool drive:	Flat (~DIN 1809)
	Shank size [mm]:	55.00
	Shank type:	BMT
	Tool adaption:	ER 25 A - u-tec
	Gear ratio [i]:	1:1
	Torque max [Nm]:	50
	Rotation max [1/min]:	12000
	Rotating direction:	same
	Coolant:	EXT
	Pressure max [bar]:	140
<b>8 010 55 051</b>	<b>Axial drilling and milling head Weldon 3/4"</b>	
	Weight [kg]:	3.390
	Tool drive:	Flat (~DIN 1809)
	Shank size [mm]:	55.00
	Shank type:	BMT
	Tool adaption:	Weldon (DIN 1835 b) 3/4" (19,05mm)
	Gear ratio [i]:	1:1
	Torque max [Nm]:	50
	Rotation max [1/min]:	6000
	Rotating direction:	same
	Coolant:	EXT
	Please note:	Combi bearing
<b>8 010 55 080</b>	<b>Axial drilling and milling head C 3</b>	
	Weight [kg]:	4.240
	Notation:	180° reversible
	Tool drive:	Flat (~DIN 1809)
	Shank size [mm]:	55.00
	Shank type:	BMT
	Tool adaption:	heimatec Capto(TM) C 3
	Gear ratio [i]:	1:1
	Torque max [Nm]:	50
	Rotation max [1/min]:	6000
	Rotating direction:	same
	Coolant:	EXT
	Please note:	Check applicability; tool length check !

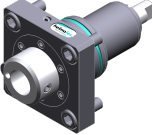
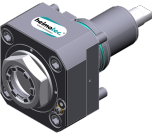
Part-#	Name	
<b>8 010 55 120</b>	<b>Axial drilling and milling head ER 25 AX UT</b>	
	Weight [kg]:	3.190
	Tool drive:	Flat (~DIN 1809)
	Shank size [mm]:	55.00
	Shank type:	BMT
	Tool adaption:	ER 25 A - u-tec
	Gear ratio [i]:	1:1
	Torque max [Nm]:	50
	Rotation max [1/min]:	8000
	Rotating direction:	same
	Coolant:	EXT
<b>8 010 56 035</b>	<b>Axial drilling and milling head HT 4 IC</b>	
	Tool drive:	Flat (~DIN 1809)
	Shank size [mm]:	55.00
	Shank type:	BMT
	Tool adaption:	HT 4
	Gear ratio [i]:	1:1
	Torque max [Nm]:	50
	Rotation max [1/min]:	6000
	Rotating direction:	same
	Coolant:	IC/Ext
	Pressure max [bar]:	25
	Please note:	stronger bearing
<b>8 010 56 039</b>	<b>Axial drilling and milling head ER 32 AX UT</b>	
	Weight [kg]:	3.200
	Tool drive:	Flat (~DIN 1809)
	Shank size [mm]:	55.00
	Shank type:	BMT
	Tool adaption:	ER 32 A - u-tec
	Gear ratio [i]:	1:1
	Torque max [Nm]:	50
	Rotation max [1/min]:	6000
	Rotating direction:	same
	Coolant:	EXT
	Please note:	Combi bearing
<b>8 010 56 040</b>	<b>Axial drilling and milling head ER 32 AX UT IC</b>	
	Weight [kg]:	3.220
	Tool drive:	Flat (~DIN 1809)
	Shank size [mm]:	55.00
	Shank type:	BMT
	Tool adaption:	ER 32 A - u-tec
	Gear ratio [i]:	1:1
	Torque max [Nm]:	50
	Rotation max [1/min]:	6000
	Rotating direction:	same
	Coolant:	IC/Ext
	Pressure max [bar]:	25
	Please note:	Combi bearing

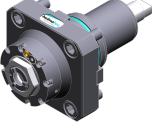
Part-#	Name	
<b>8 010 56 047</b>	<b>Axial drilling and milling head HT 4 IC</b>	
		<p>Tool drive: Flat (~DIN 1809)            Shank size [mm]: 55.00            Shank type: BMT            Tool adaption: HT 4            Gear ratio [i]: 1:1            Torque max [Nm]: 50            Rotation max [1/min]: 6000            Rotating direction: same            Coolant: IC/Ext            Pressure max [bar]: 25            Please note: Combi bearing</p>
<b>8 010 56 089</b>	<b>Axial drilling and milling head ER 32 AX UT IC</b>	
		<p>Weight [kg]: 3.700            Tool drive: Flat (~DIN 1809)            Shank size [mm]: 55.00            Shank type: BMT            Tool adaption: ER 32 A - u-tec            Gear ratio [i]: 1:1            Torque max [Nm]: 50            Rotation max [1/min]: 12000            Rotating direction: same            Coolant: IC/Ext            Pressure max [bar]: 100            Please note: Dryrun possible</p>
<b>8 010 56 119</b>	<b>Axial drilling and milling head C 4 IC</b>	
		<p>Notation: 180° reversible            Tool drive: Flat (~DIN 1809)            Shank size [mm]: 55.00            Shank type: BMT            Tool adaption: heimatec Capto(TM) C 4            Gear ratio [i]: 1:1            Torque max [Nm]: 50            Rotation max [1/min]: 6000            Rotating direction: same            Coolant: IC/Ext            Pressure max [bar]: 100            Please note: Check applicability; tool length check !;</p>
<b>8 013 54 008</b>	<b>Axial drilling and milling head ER 16 AX UT</b>	
		<p>Weight [kg]: 2.480            Tool drive: Flat (~DIN 1809)            Shank size [mm]: 55.00            Shank type: BMT            Tool adaption: ER 16 A - u-tec            Gear ratio [i]: 1:4            Torque max [Nm]: 5            Rotation max [1/min]: 24000            Rotating direction: same            Coolant: EXT</p>

Part-#	Name
--------	------

8 013 54 009

**Axial drilling and milling head ER 16 AX UT IC**



Tool drive: Flat (~DIN 1809)  
Shank size [mm]: 55.00  
Shank type: BMT  
Tool adaption: ER 16 A - u-tec  
Gear ratio [i]: 1:4  
Torque max [Nm]: 5  
Rotation max [1/min]: 24000  
Rotating direction: same  
Coolant: IC/Ext  
Pressure max [bar]: 100

8 019 55 050

**Axial drilling and milling head ER 25 AX UT**



Weight [kg]: 5.000  
Notation: offset; 180° reversible  
Tool drive: Flat (~DIN 1809)  
Shank size [mm]: 55.00  
Shank type: BMT  
Tool adaption: ER 25 A - u-tec  
Gear ratio [i]: 1:1  
Torque max [Nm]: 40  
Rotation max [1/min]: 8000  
Rotating direction: opposite  
Coolant: EXT  
Please note: stronger bearing  
Offset [mm]: 42

8 019 55 051

**Axial drilling and milling head ER 25 AX UT**



Weight [kg]: 5.010  
Notation: offset; 180° reversible  
Tool drive: Flat (~DIN 1809)  
Shank size [mm]: 55.00  
Shank type: BMT  
Tool adaption: ER 25 A - u-tec  
Gear ratio [i]: 2:1  
Torque max [Nm]: 50  
Rotation max [1/min]: 3000  
Rotating direction: opposite  
Coolant: EXT  
Please note: stronger bearing  
Offset [mm]: 42

8 019 55 052

**Axial drilling and milling head ER 25 AX UT**



Weight [kg]: 5.020  
Notation: offset; 180° reversible  
Tool drive: Flat (~DIN 1809)  
Shank size [mm]: 55.00  
Shank type: BMT  
Tool adaption: ER 25 A - u-tec  
Gear ratio [i]: 1:3  
Torque max [Nm]: 16  
Rotation max [1/min]: 18000  
Rotating direction: opposite  
Coolant: EXT  
Please note: stronger bearing  
Offset [mm]: 42

Part-#	Name
--------	------

8 019 55 053



**Axial drilling and milling head ER 25 AX UT**

Weight [kg]: 4.980  
 Notation: offset; 180° reversible  
 Tool drive: Flat (~DIN 1809)  
 Shank size [mm]: 55.00  
 Shank type: BMT  
 Tool adaption: ER 25 A - u-tec  
 Gear ratio [i]: 1:2  
 Torque max [Nm]: 25  
 Rotation max [1/min]: 16000  
 Rotating direction: opposite  
 Coolant: EXT  
 Please note: stronger bearing  
 Offset [mm]: 42

8 019 55 054



**Axial drilling and milling head ER 25 AX UT IC**

Notation: offset; 180° reversible  
 Tool drive: Flat (~DIN 1809)  
 Shank size [mm]: 55.00  
 Shank type: BMT  
 Tool adaption: ER 25 A - u-tec  
 Gear ratio [i]: 1:1  
 Torque max [Nm]: 40  
 Rotation max [1/min]: 6000  
 Rotating direction: opposite  
 Coolant: IC/Ext  
 Pressure max [bar]: 140  
 Please note: stronger bearing  
 Offset [mm]: 42

8 019 55 056



**Axial drilling and milling head ER 25 AX UT IC**

Weight [kg]: 6.130  
 Notation: offset; 180° reversible  
 Tool drive: Flat (~DIN 1809)  
 Shank size [mm]: 55.00  
 Shank type: BMT  
 Tool adaption: ER 25 A - u-tec  
 Gear ratio [i]: 1:3  
 Torque max [Nm]: 16  
 Rotation max [1/min]: 18000  
 Rotating direction: opposite  
 Coolant: IC/Ext  
 Pressure max [bar]: 140  
 Please note: stronger bearing  
 Offset [mm]: 42

8 019 55 057



**Axial drilling and milling head ER 25 AX UT IC**

Weight [kg]: 6.060  
 Notation: offset; 180° reversible  
 Tool drive: Flat (~DIN 1809)  
 Shank size [mm]: 55.00  
 Shank type: BMT  
 Tool adaption: ER 25 A - u-tec  
 Gear ratio [i]: 1:2  
 Torque max [Nm]: 25  
 Rotation max [1/min]: 16000

Part-#	Name
--------	------

Rotating direction: opposite  
Coolant: IC/Ext  
Pressure max [bar]: 140  
Please note: stronger bearing  
Offset [mm]: 42

**8 030 54 079 Radial drilling and milling head ER 16 AX UT**

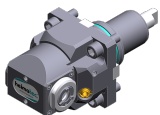

Weight [kg]: 4.200  
Notation: 180° reversible  
Tool drive: Flat (~DIN 1809)  
Shank size [mm]: 55.00  
Shank type: BMT  
Tool adaption: ER 16 A - u-tec  
Gear ratio [i]: 1:1  
Torque max [Nm]: 10  
Rotation max [1/min]: 6000  
Rotating direction: opposite  
Coolant: EXT  
Center distance [mm]: 70

**8 030 55 093 Angle-mill- and drill holder ER 25 AX UT**



Notation: 180° reversible  
Tool drive: Flat (~DIN 1809)  
Shank size [mm]: 55.00  
Shank type: BMT  
Tool adaption: ER 25 A - u-tec  
Gear ratio [i]: 1:1  
Torque max [Nm]: 50  
Rotation max [1/min]: 5000  
Rotating direction: same  
Coolant: EXT  
Please note: Combi bearing  
Center distance [mm]: 85

**8 030 55 143 Radial drilling and milling head ER 25 AX UT**



Notation: 180° reversible  
Tool drive: Flat (~DIN 1809)  
Shank size [mm]: 55.00  
Shank type: BMT  
Tool adaption: ER 25 A - u-tec  
Gear ratio [i]: 1:3  
Torque max [Nm]: 12  
Rotation max [1/min]: 18000  
Rotating direction: same  
Coolant: EXT  
Please note: stronger bearing  
Center distance [mm]: 85

**8 030 55 156 Radial drilling and milling head ER 25 AX UT IC**



Weight [kg]: 6.820  
Notation: 180° reversible  
Version: Special  
Tool drive: Flat (~DIN 1809)  
Shank size [mm]: 55.00  
Shank type: BMT  
Tool adaption: ER 25 A - u-tec

Part-#	Name
--------	------

Gear ratio [i]: 1:2  
 Torque max [Nm]: 16  
 Rotation max [1/min]: 12000  
 Rotating direction: same  
 Coolant: IC  
 Pressure max [bar]: 140  
 Please note: stronger bearing  
 Center distance [mm]: 85

**8 030 55 184 Radial drilling and milling head ER 25 AX UT IC**



Weight [kg]: 6.830  
 Notation: 180° reversible  
 Tool drive: Flat (~DIN 1809)  
 Shank size [mm]: 55.00  
 Shank type: BMT  
 Tool adaption: ER 25 A - u-tec  
 Gear ratio [i]: 1:3  
 Torque max [Nm]: 12  
 Rotation max [1/min]: 18000  
 Rotating direction: same  
 Coolant: IC/Ext  
 Pressure max [bar]: 140  
 Please note: stronger bearing  
 Center distance [mm]: 85

**8 030 55 255 Radial drilling and milling head ER 25 AX UT**



Weight [kg]: 7.600  
 Notation: 180° reversible  
 Tool drive: Flat (~DIN 1809)  
 Shank size [mm]: 55.00  
 Shank type: BMT  
 Tool adaption: ER 25 A - u-tec  
 Gear ratio [i]: 1:1  
 Torque max [Nm]: 50  
 Rotation max [1/min]: 12000  
 Rotating direction: same  
 Coolant: EXT  
 Center distance [mm]: 85

**8 030 55 256 Radial drilling and milling head ER 25 AX UT IC**







Weight [kg]: 8.200  
 Notation: 180° reversible  
 Tool drive: Flat (~DIN 1809)  
 Shank size [mm]: 55.00  
 Shank type: BMT  
 Tool adaption: ER 25 A - u-tec  
 Gear ratio [i]: 1:1  
 Torque max [Nm]: 50  
 Rotation max [1/min]: 12000  
 Rotating direction: same  
 Coolant: IC/Ext  
 Pressure max [bar]: 140  
 Center distance [mm]: 85

Part-#	Name	
	<b>8 030 56 173</b>	<b>Radial drilling and milling head ER 32 AX UT</b>
	Notation:	180° reversible
	Tool drive:	Flat (~DIN 1809)
	Shank size [mm]:	55.00
	Shank type:	BMT
	Tool adaption:	ER 32 A - u-tec
	Gear ratio [i]:	2:1
	Torque max [Nm]:	63
	Rotation max [1/min]:	6000
	Rotating direction:	opposite
	Coolant:	EXT
Please note:	Combi bearing	
Center distance [mm]:	85	
	<b>8 030 56 186</b>	<b>Radial drilling and milling head C 4</b>
	Weight [kg]:	10.200
	Notation:	180° reversible
	Tool drive:	Flat (~DIN 1809)
	Shank size [mm]:	55.00
	Shank type:	BMT
	Tool adaption:	heimatec Capto(TM) C 4
	Gear ratio [i]:	1:1
	Torque max [Nm]:	40
	Rotation max [1/min]:	6000
	Rotating direction:	opposite
Coolant:	EXT	
Please note:	Check applicability; note tool length!	
Center distance [mm]:	85	
	<b>8 030 56 187</b>	<b>Radial drilling and milling head C 4 IC</b>
	Weight [kg]:	10.440
	Notation:	180° reversible
	Tool drive:	Flat (~DIN 1809)
	Shank size [mm]:	55.00
	Shank type:	BMT
	Tool adaption:	heimatec Capto(TM) C 4
	Gear ratio [i]:	1:1
	Torque max [Nm]:	40
	Rotation max [1/min]:	6000
	Rotating direction:	opposite
Coolant:	IC/Ext	
Pressure max [bar]:	140	
Please note:	Check applicability; note tool length!	
Center distance [mm]:	85	
	<b>8 030 56 246</b>	<b>Radial drilling and milling head ER 32 AX UT IC</b>
	Weight [kg]:	7.660
	Notation:	180° reversible
	Tool drive:	Flat (~DIN 1809)
	Shank size [mm]:	55.00
	Shank type:	BMT
	Tool adaption:	ER 32 A - u-tec
	Gear ratio [i]:	1:1
	Torque max [Nm]:	50
	Rotation max [1/min]:	12000
Rotating direction:	same	

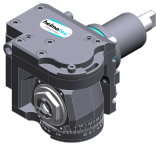
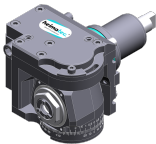
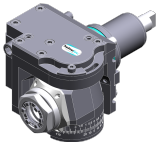
Part-#	Name	
	Coolant:	IC/Ext
	Pressure max [bar]:	140
	Center distance [mm]:	85
<b>8 030 56 247</b>	<b>Radial drilling and milling head ER 32 AX UT</b>	
	Weight [kg]:	7.550
	Notation:	180° reversible
	Tool drive:	Flat (~DIN 1809)
	Shank size [mm]:	55.00
	Shank type:	BMT
	Tool adaption:	ER 32 A - u-tec
	Gear ratio [i]:	1:1
	Torque max [Nm]:	50
	Rotation max [1/min]:	12000
	Rotating direction:	same
	Coolant:	EXT
	Center distance [mm]:	85
<b>8 031 55 022</b>	<b>Radial milling head universal arbor 22</b>	
	Weight [kg]:	8.100
	Notation:	180° reversible
	Tool drive:	Flat (~DIN 1809)
	Shank size [mm]:	55.00
	Shank type:	BMT
	Tool adaption:	Universal arbor 22
	Gear ratio [i]:	2:1
	Torque max [Nm]:	63
	Rotation max [1/min]:	3000
	Rotating direction:	opposite
	Coolant:	EXT
	Please note:	Combi bearing
	Center distance [mm]:	85
<b>8 037 54 024</b>	<b>Radial disk mill head arbor 16</b>	
	Weight [kg]:	11.300
	Notation:	180° reversible
	Version:	± 20° turnable; at 0° position can be pinned
	Tool drive:	Flat (~DIN 1809)
	Shank size [mm]:	55.00
	Shank type:	BMT
	Tool adaption:	Arbor 16
	Gear ratio [i]:	2:1
	Torque max [Nm]:	63
	Rotation max [1/min]:	3000
	Rotating direction:	same
	Coolant:	no
	Please note:	strong version with stronger bearing; use
	Center distance [mm]:	83,5
<b>8 037 54 025</b>	<b>Radial disk mill head arbor 16</b>	
	Version:	360° turnable
	Tool drive:	Flat (~DIN 1809)
	Shank size [mm]:	55.00
	Shank type:	BMT
	Tool adaption:	Arbor 16
	Gear ratio [i]:	1:1

Part-#	Name	
		Torque max [Nm]: 50 Rotation max [1/min]: 4000 Rotating direction: opposite Coolant: EXT Please note: Check applicability; note tool length; Center distance [mm]: 89
<b>8 037 55 039</b>	<b>Radial disk mill head arbor 1"</b>	
		Weight [kg]: 10.220 Tool drive: Flat (~DIN 1809) Shank size [mm]: 55.00 Shank type: BMT Tool adaption: Arbor 1" (25,4mm) Gear ratio [i]: 2:1 Torque max [Nm]: 80 Rotation max [1/min]: 4000 Rotating direction: same Coolant: EXT Please note: Check applicability; note tool length; Center distance [mm]: 81
<b>8 039 55 026</b>	<b>Radial drilling and milling head ER 25 AX UT</b>	
		Weight [kg]: 7.000 Notation: 180° reversible Employment for: Main- and sub spindle Version: double spindle Tool drive: Flat (~DIN 1809) Shank size [mm]: 55.00 Shank type: BMT Tool adaption: ER 25 A - u-tec Gear ratio [i]: 1:1 Torque max [Nm]: 50 Rotation max [1/min]: 12000 Rotating direction: same/opposite Coolant: EXT Please note: stronger bearing Center distance [mm]: 85
<b>8 039 56 029</b>	<b>Radial drilling and milling head ER 32 AX UT</b>	
		Weight [kg]: 6.840 Notation: 180° reversible Employment for: Main- and sub spindle Version: double spindle Tool drive: Flat (~DIN 1809) Shank size [mm]: 55.00 Shank type: BMT Tool adaption: ER 32 A - u-tec Gear ratio [i]: 1:1 Torque max [Nm]: 50 Rotation max [1/min]: 12000 Rotating direction: same/opposite Coolant: EXT Please note: stronger bearing Center distance [mm]: 85



Part-#	Name	
<b>8 039 56 045</b>	<b>Radial drilling and milling head ER 32 AX UT</b>	
	Weight [kg]:	8.600
	Notation:	180° reversible
	Employment for:	Main- and sub spindle
	Version:	double spindle
	Tool drive:	Flat (~DIN 1809)
	Shank size [mm]:	55.00
	Shank type:	BMT
	Tool adaption:	ER 32 A - u-tec
	Gear ratio [i]:	1:1
	Torque max [Nm]:	50
	Rotation max [1/min]:	6000
	Rotating direction:	same/opposite
	Coolant:	EXT
	Please note:	stronger bearing
	Center distance [mm]:	100
<b>8 043 54 006</b>	<b>Universal head +110°/-20° adj. ER16 AX UT</b>	
	Weight [kg]:	5.940
	Notation:	offset; 180° reversible
	Tool drive:	Flat (~DIN 1809)
	Shank size [mm]:	55.00
	Shank type:	BMT
	Tool adaption:	ER 16 A - u-tec
	Gear ratio [i]:	1:1
	Torque max [Nm]:	25
	Rotation max [1/min]:	6000
	Rotating direction:	opposite
	Coolant:	EXT
	Center distance [mm]:	50
	Offset [mm]:	35
<b>8 043 54 013</b>	<b>Universal head +110°/-20° adj. ER16 AX UT</b>	
	Weight [kg]:	6.320
	Notation:	offset; 180° reversible
	Tool drive:	Flat (~DIN 1809)
	Shank size [mm]:	55.00
	Shank type:	BMT
	Tool adaption:	ER 16 A - u-tec
	Gear ratio [i]:	1:2
	Torque max [Nm]:	12
	Rotation max [1/min]:	12000
	Rotating direction:	opposite
	Coolant:	EXT
	Center distance [mm]:	50
	Offset [mm]:	35
<b>8 043 55 005</b>	<b>Universal head +110°/-20° adj. ER25 AX UT</b>	
	Weight [kg]:	6.170
	Notation:	offset, 180° reversible
	Tool drive:	Flat (~DIN 1809)
	Shank size [mm]:	55.00
	Shank type:	BMT
	Tool adaption:	ER 25 A - u-tec
	Gear ratio [i]:	1:1
	Torque max [Nm]:	25

Part-#	Name	
	Rotation max [1/min]:	6000
	Rotating direction:	opposite
	Coolant:	EXT
	Please note:	stronger bearing
	Center distance [mm]:	50
	Offset [mm]:	35
<b>8 043 55 009</b>	<b>Universal head +110°/-20° adj. ER25AX UTIK</b>	
	Weight [kg]:	6.320
	Notation:	offset, 180° reversible
	Tool drive:	Flat (~DIN 1809)
	Shank size [mm]:	55.00
	Shank type:	BMT
	Tool adaption:	ER 25 A - u-tec
	Gear ratio [i]:	1:1
	Torque max [Nm]:	25
	Rotation max [1/min]:	6000
	Rotating direction:	opposite
	Coolant:	IC/Ext
	Pressure max [bar]:	25
	Please note:	stronger bearing
	Center distance [mm]:	50
	Offset [mm]:	35
<b>8 043 55 027</b>	<b>Universal head +110°/-20° adj. ER25 AX UT</b>	
	Weight [kg]:	6.180
	Notation:	offset, 180° reversible
	Version:	at 45° position can be pinned
	Tool drive:	Flat (~DIN 1809)
	Shank size [mm]:	55.00
	Shank type:	BMT
	Tool adaption:	ER 25 A - u-tec
	Gear ratio [i]:	1:1
	Torque max [Nm]:	25
	Rotation max [1/min]:	6000
	Rotating direction:	opposite
	Coolant:	EXT
	Please note:	stronger bearing
	Center distance [mm]:	50
	Offset [mm]:	35
<b>8 053 54 021</b>	<b>Multispindle radial head ER 16 AX UT</b>	
	Weight [kg]:	8.510
	Notation:	180° reversible
	Version:	2-spindles
	Tool drive:	Flat (~DIN 1809)
	Shank size [mm]:	55.00
	Shank type:	BMT
	Tool adaption:	ER 16 A - u-tec
	Gear ratio [i]:	1:1
	Torque max [Nm]:	25
	Rotation max [1/min]:	6000
	Rotating direction:	same
	Coolant:	EXT
	Center distance [mm]:	85

Part-#	Name	
<b>8 053 54 029</b>	<b>Multispindle radial head ER 16 AX UT</b>	
	Weight [kg]:	8.440
	Notation:	180° reversible
	Version:	2-spindles
	Tool drive:	Flat (~DIN 1809)
	Shank size [mm]:	55.00
	Shank type:	BMT
	Tool adaption:	ER 16 A - u-tec
	Gear ratio [i]:	1:2
	Torque max [Nm]:	8
	Rotation max [1/min]:	12000
	Rotating direction:	same
	Coolant:	EXT
	Center distance [mm]:	85
<b>8 200 02 003</b>	<b>Cover plate</b>	
	Weight [kg]:	0.361
	Shank size [mm]:	55.00
	Shank type:	BMT
<b>8 202 00 009</b>	<b>Basic holder longitudinal seat FN 12</b>	
	Weight [kg]:	1.140
	Notation:	180° reversible
	Shank type:	BMT
	Machine adaption:	Centering key b 15
	Tool adaption:	Interface FN 12
	Coolant:	EXT
<b>8 224 03 003</b>	<b>Cut-off holder SH 32</b>	
	Weight [kg]:	1.810
	Notation:	180° reversible
	Employment for:	Cut-off tool 32
	Version:	Clampshaft on turret side
	Shank type:	BMT
	Machine adaption:	Centering key b 15
	Tool adaption:	Clampshaft SH 32
	Coolant:	EXT
<b>8 224 04 002</b>	<b>Universal turning holder sq. 20</b>	
	Weight [kg]:	3.460
	Shank type:	BMT
	Machine adaption:	Centering key b 15
	Tool adaption:	Sq. 20
	Coolant:	EXT

Part-#	Name	
<b>8 224 04 062</b>	<b>Universal turning holder sq. 20 IC</b>	
	Weight [kg]:	3.020
	Shank type:	BMT
	Machine adaption:	Centering key b 15
	Tool adaption:	Sq. 20
		Sq. 20
	Coolant:	IC/Ext
	Pressure max [bar]:	100
	Please note:	Key rail
<b>8 224 05 003</b>	<b>Universal turning holder sq. 25</b>	
	Weight [kg]:	3.620
	Notation:	180° reversible
	Shank type:	BMT
	Machine adaption:	Centering key b 15
	Tool adaption:	Sq. 25
	Coolant:	EXT
<b>8 224 05 005</b>	<b>Universal turning holder sq. 1"</b>	
	Weight [kg]:	3.560
	Shank type:	BMT
	Machine adaption:	Centering key b 15
	Tool adaption:	Sq. 1" (25,4mm)
	Coolant:	EXT
<b>8 224 05 015</b>	<b>Universal turning holder sq. 25/20</b>	
	Weight [kg]:	3.780
	Notation:	180° reversible
	Shank type:	BMT
	Machine adaption:	Centering key b 15
	Tool adaption:	Sq. 25/20
	Coolant:	EXT
	Pressure max [bar]:	80
	Please note:	with spacer strip for sq. 20
<b>8 224 05 023</b>	<b>Universal turning holder sq. 25/20</b>	
	Weight [kg]:	3.150
	Notation:	180° reversible
	Shank type:	BMT
	Machine adaption:	Centering key b 15
	Tool adaption:	Sq. 25/20
	Coolant:	EXT
	Please note:	with spacer strip for sq. 20
<b>8 240 07 043</b>	<b>Boring bar holder Ø 1 1/4"</b>	
	Weight [kg]:	7.540
	Notation:	180° reversible
	Shank type:	BMT
	Machine adaption:	Centering key b 15
	Tool adaption:	Ø 1 1/4" (31,75mm)
	Coolant:	IC/Ext
	Center distance [mm]:	95

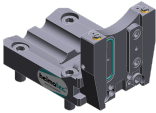
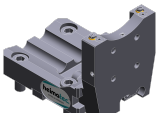
Part-#	Name	
<b>8 240 09 039</b>	<b>Boring bar holder Ø 40</b>	
	Weight [kg]:	7.050
	Notation:	180° reversible
	Employment for:	Main- and sub spindle
	Shank type:	BMT
	Machine adaption:	Centering key slot b 15
	Tool adaption:	Ø 40
	Coolant:	IC/Ext
	Center distance [mm]:	95
<b>8 244 05 003</b>	<b>Combi facing holder sq. 25</b>	
	Weight [kg]:	5.340
	Notation:	180° reversible
	Employment for:	Main- and sub spindle
	Shank type:	BMT
	Machine adaption:	Centering key b 15
	Tool adaption:	Sq. 25
	Coolant:	EXT
	Pressure max [bar]:	80
<b>8 244 05 006</b>	<b>Combi facing holder sq. 1"</b>	
	Weight [kg]:	5.310
	Notation:	180° reversible
	Employment for:	Main- and sub spindle
	Shank type:	BMT
	Machine adaption:	Centering key b 15
	Tool adaption:	Sq. 1" (25,4mm)
	Coolant:	EXT
<b>8 251 05 001</b>	<b>Combi double turning holder sq. 25</b>	
	Weight [kg]:	7.700
	Employment for:	Main- and sub spindle
	Shank type:	BMT
	Machine adaption:	Centering key b 15
	Tool adaption:	Sq. 25
		Sq. 25
		Sq. 25
		Sq. 25
	Coolant:	EXT
	Pressure max [bar]:	80
<b>8 259 04 007</b>	<b>Multiple turning holder sq. 20</b>	
	Weight [kg]:	8.180
	Notation:	180° reversible
	Employment for:	Main- and sub spindle
	Version:	Special
	Shank type:	BMT
	Machine adaption:	Centering key b 15
	Tool adaption:	Sq. 20
		Sq. 20
		Sq. 20
	Coolant:	IC/Ext

Part-#	Name	
<b>8 320 03 008</b>	<b>Cut-off holder, height adjustable SH 32 IC</b>	
	Weight [kg]:	1.790
	Notation:	180° reversible
	Shank type:	BMT
	Machine adaption:	Centering key b 15
	Tool adaption:	Clampshaft SH 32
	Coolant:	IC/Ext
	Pressure max [bar]:	70
<b>8 320 03 025</b>	<b>Cut-off holder, height adjustable SH 32 IC</b>	
	Weight [kg]:	1.910
	Notation:	180° reversible
	Shank type:	BMT
	Machine adaption:	Centering key b 15
	Tool adaption:	Clampshaft SH 32
	Coolant:	IC/Ext
	Pressure max [bar]:	70
	Please note:	Clampshaft internal
<b>8 320 09 001</b>	<b>Cut-off holder, height adjustable 845 IC</b>	
	Weight [kg]:	1.730
	Notation:	180° reversible
	Shank type:	BMT
	Machine adaption:	Centering key b 15
	Tool adaption:	 System 845
	Coolant:	IC
	Pressure max [bar]:	70

## heimatec.u-tec®

heimatec.com

Products / Tool change systems /  
u-tec® Tool-changing system



versions see catalog



## heimatec.easy-quick

heimatec.com

Products / Tool change systems /  
easy-quick HT quick-changing system



versions see catalog



## heimatec.Capto™

heimatec.com

Products / Tool change systems /  
heimatec.Capto™ quick-changing system



versions see catalog

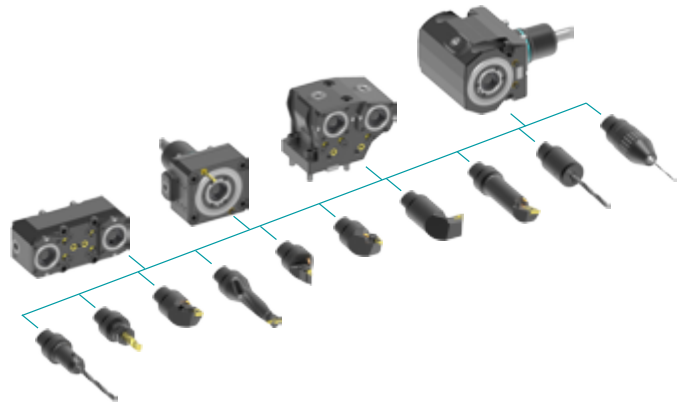

## heimatec.accessories

heimatec.com

Products / Accessories



versions see catalog





● heimatec overseas branches

○ global representations of heimatec

**heimatec**<sup>®</sup>

**heimatec GmbH**  
Präzisionswerkzeuge  
Carl-Benz-Str. 4  
77871 Renchen  
Germany

T +49 7843 9466 0  
[www.heimatec.com](http://www.heimatec.com)  
[info@heimatec.com](mailto:info@heimatec.com)

Please find the contact details of our worldwide trading partners on our website:  
<https://heimatec.com/business-partners>