

Doosan

Lynx 2100

LMSA/LMSB

BMT 45



High-tech from heimatec - heimatec - Tools and systems for productive turning and milling

heimatec belongs to the international technology and quality leaders for precision tools and specializes in the development and production of high-precision static and live tools for all CNC lathes, CNC turn-/mill machines and CNC machining centers.

The range of products* spans from static BMT and VDI tool holders, live tools up to highly complex customer-specific individual solutions. heimatec, headquartered in Renchen, has a own subsidiary in Asia and India and numerous representatives as well as trading partners all over the world.

*OUR PRODCUTS

Static tool holders

Live tool units

Precision tools

Tools for turning and machining centres

Tools for swiss type lathes

Tool changing and uick-change systems

Tool systems for gear production



Digital tool management



This catalogue, including all its parts, is protected by copyright. Any use outside the restricted limitations of the Copyright Act without the consent of heimatec is inadmissible and liable to prosecution. This applies in particular to duplication, translation, microfilming and storage and processing in electronic systems.

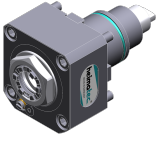

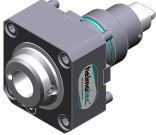
heimatec GmbH reserves the right to make technical changes at any time without giving prior notice. This applies in particular to adjustments at any time to meet new or changed international standards, or in case of further developments of our products or manufacturing processes.

The current version of our General Terms and Conditions can be found on our website.

Part-#	Name	
	8 010 45 129	Axial drilling and milling head ER 25 AX UT
	Weight [kg]:	1.830
	Tool drive:	Flat (~DIN 1809)
	Shank size [mm]:	45.00
	Shank type:	BMT
	Tool adaption:	ER 25 A - u-tec
	Gear ratio [i]:	1:1
	Torque max [Nm]:	32
	Rotation max [1/min]:	10000
	Rotating direction:	same
Coolant:	EXT	
	8 010 45 130	Axial drilling and milling head ER 25 AX UT IC
	Weight [kg]:	2.020
	Tool drive:	Flat (~DIN 1809)
	Shank size [mm]:	45.00
	Shank type:	BMT
	Tool adaption:	ER 25 A - u-tec
	Gear ratio [i]:	1:1
	Torque max [Nm]:	32
	Rotation max [1/min]:	6000
	Rotating direction:	same
Coolant:	IC/Ext	
Pressure max [bar]:	25	
Please note:	Combi bearing	
	8 010 45 202	Axial drilling and milling head ER 25 AX UT
	Weight [kg]:	1.740
	Tool drive:	Flat (~DIN 1809)
	Shank size [mm]:	45.00
	Shank type:	BMT
	Tool adaption:	ER 25 A - u-tec
	Gear ratio [i]:	1:1
	Torque max [Nm]:	32
	Rotation max [1/min]:	10000
	Rotating direction:	same
Coolant:	EXT	
	8 010 45 220	Axial drilling and milling head ER 25 AX UT IC
	Tool drive:	Flat (~DIN 1809)
	Shank size [mm]:	45.00
	Shank type:	BMT
	Tool adaption:	ER 25 A - u-tec
	Gear ratio [i]:	1:1
	Torque max [Nm]:	50
	Rotation max [1/min]:	15000
	Rotating direction:	same
	Coolant:	IC/Ext
Pressure max [bar]:	100	
Please note:	Dryrun possible	



Part-#	Name	
	8 010 46 258	Axial drilling and milling head HT 4 IC
	Weight [kg]:	2.090
	Tool drive:	Flat (~DIN 1809)
	Shank size [mm]:	45.00
	Shank type:	BMT
	Tool adaption:	HT 4
	Gear ratio [i]:	1:1
	Torque max [Nm]:	32
	Rotation max [1/min]:	6000
	Rotating direction:	same
	Coolant:	IC/Ext
Pressure max [bar]:	25	
	8 010 46 272	Axial drilling and milling head ER 32 AX UT
	Tool drive:	Flat (~DIN 1809)
	Shank size [mm]:	45.00
	Shank type:	BMT
	Tool adaption:	ER 32 A - u-tec
	Gear ratio [i]:	1:1
	Torque max [Nm]:	32
	Rotation max [1/min]:	8000
	Rotating direction:	same
	Coolant:	EXT
	Please note:	stronger bearing
	8 010 46 327	Axial drilling and milling head HT 4 IC
	Weight [kg]:	2.200
	Tool drive:	Flat (~DIN 1809)
	Shank size [mm]:	45.00
	Shank type:	BMT
	Tool adaption:	HT 4
	Gear ratio [i]:	1:1
	Torque max [Nm]:	50
	Rotation max [1/min]:	15000
	Rotating direction:	same
	Coolant:	IC/Ext
Pressure max [bar]:	100	
Please note:	Dryrun possible	
	8 019 45 162	Axial drilling and milling head ER 25 AX UT
	Notation:	offset
	Tool drive:	Flat (~DIN 1809)
	Shank size [mm]:	45.00
	Shank type:	BMT
	Tool adaption:	ER 25 A - u-tec
	Gear ratio [i]:	1:2
	Torque max [Nm]:	25
	Rotation max [1/min]:	12000
	Rotating direction:	opposite
	Coolant:	EXT
Please note:	stronger bearing	
Offset [mm]:	42	

Part-#	Name	
8 019 45 163	Axial drilling and milling head ER 25 AX UT IC	
	Weight [kg]:	5.940
	Notation:	offset; 180°reversible
	Tool drive:	Flat (~DIN 1809)
	Shank size [mm]:	45.00
	Shank type:	BMT
	Tool adaption:	ER 25 A - u-tec
	Gear ratio [i]:	1:2
	Torque max [Nm]:	25
	Rotation max [1/min]:	12000
	Rotating direction:	opposite
	Coolant:	IC/Ext
	Pressure max [bar]:	140
	Please note:	stronger bearing
	Offset [mm]:	42
8 019 45 164	Axial drilling and milling head ER 25 AX UT	
	Notation:	offset
	Tool drive:	Flat (~DIN 1809)
	Shank size [mm]:	45.00
	Shank type:	BMT
	Tool adaption:	ER 25 A - u-tec
	Gear ratio [i]:	1:3
	Torque max [Nm]:	16
	Rotation max [1/min]:	18000
	Rotating direction:	opposite
	Coolant:	EXT
	Please note:	stronger bearing
	Offset [mm]:	42
8 019 45 165	Axial drilling and milling head ER 25 AX UT IC	
	Notation:	offset; 180° reversible
	Tool drive:	Flat (~DIN 1809)
	Shank size [mm]:	45.00
	Shank type:	BMT
	Tool adaption:	ER 25 A - u-tec
	Gear ratio [i]:	1:3
	Torque max [Nm]:	16
	Rotation max [1/min]:	18000
	Rotating direction:	opposite
	Coolant:	IC/Ext
	Pressure max [bar]:	140
	Please note:	stronger bearing
	Offset [mm]:	42
8 019 45 174	Axial drilling and milling head ER 25 AX UT IC	
	Notation:	offset
	Tool drive:	Flat (~DIN 1809)
	Shank size [mm]:	45.00
	Shank type:	BMT
	Tool adaption:	ER 25 A - u-tec
	Gear ratio [i]:	2:1
	Torque max [Nm]:	50
	Rotation max [1/min]:	3000
	Rotating direction:	opposite
	Coolant:	IC/Ext
	Pressure max [bar]:	140



Part-#	Name	
	Please note:	stronger bearing
	Offset [mm]:	42
8 030 44 098	Radial drilling and milling head ER 16 AX UT	
	Notation:	180° reversible
	Tool drive:	Flat (~DIN 1809)
	Shank size [mm]:	45.00
	Shank type:	BMT
	Tool adaption:	ER 16 A - u-tec
	Gear ratio [i]:	1:4
	Torque max [Nm]:	5
	Rotation max [1/min]:	24000
	Rotating direction:	opposite
	Coolant:	EXT
	Center distance [mm]:	65
8 030 45 228	Radial drilling and milling head ER 25 AX UT IC	
	Weight [kg]:	6.590
	Notation:	180° reversible
	Tool drive:	Flat (~DIN 1809)
	Shank size [mm]:	45.00
	Shank type:	BMT
	Tool adaption:	ER 25 A - u-tec
	Gear ratio [i]:	1:3
	Torque max [Nm]:	12
	Rotation max [1/min]:	18000
	Rotating direction:	same
	Coolant:	IC/Ext
	Pressure max [bar]:	140
	Please note:	stronger bearing
	Center distance [mm]:	85
8 030 45 229	Radial drilling and milling head ER 25 AX UT IC	
	Notation:	180° reversible
	Tool drive:	Flat (~DIN 1809)
	Shank size [mm]:	45.00
	Shank type:	BMT
	Tool adaption:	ER 25 A - u-tec
	Gear ratio [i]:	1:2
	Torque max [Nm]:	16
	Rotation max [1/min]:	12000
	Rotating direction:	same
	Coolant:	IC/Ext
	Pressure max [bar]:	140
	Please note:	stronger bearing
	Center distance [mm]:	85
8 030 45 230	Radial drilling and milling head ER 25 AX UT	
	Notation:	180° reversible
	Tool drive:	Flat (~DIN 1809)
	Shank size [mm]:	45.00
	Shank type:	BMT
	Tool adaption:	ER 25 A - u-tec
	Gear ratio [i]:	1:3
	Torque max [Nm]:	12
	Rotation max [1/min]:	18000
	Rotating direction:	same

Part-#	Name	
	Coolant:	EXT
	Please note:	stronger bearing
	Center distance [mm]:	85
8 030 45 231	Radial drilling and milling head ER 25 AX UT	
	Weight [kg]:	6.400
	Notation:	180° reversible
	Tool drive:	Flat (~DIN 1809)
	Shank size [mm]:	45.00
	Shank type:	BMT
	Tool adaption:	ER 25 A - u-tec
	Gear ratio [i]:	1:2
	Torque max [Nm]:	16
	Rotation max [1/min]:	12000
	Rotating direction:	same
	Coolant:	EXT
	Please note:	stronger bearing
	Center distance [mm]:	85
8 030 45 270	Radial drilling and milling head ER 25 AX UT	
	Weight [kg]:	5.440
	Notation:	180° reversible
	Tool drive:	Flat (~DIN 1809)
	Shank size [mm]:	45.00
	Shank type:	BMT
	Tool adaption:	ER 25 A - u-tec
	Gear ratio [i]:	1:1
	Torque max [Nm]:	50
	Rotation max [1/min]:	8000
	Rotating direction:	opposite
	Coolant:	EXT
	Please note:	stronger bearing
	Center distance [mm]:	65
8 030 45 271	Radial drilling and milling head ER 25 AX UT IC	
	Weight [kg]:	5.740
	Notation:	180° reversible
	Tool drive:	Flat (~DIN 1809)
	Shank size [mm]:	45.00
	Shank type:	BMT
	Tool adaption:	ER 25 A - u-tec
	Gear ratio [i]:	1:1
	Torque max [Nm]:	50
	Rotation max [1/min]:	8000
	Rotating direction:	opposite
	Coolant:	IC/Ext
	Pressure max [bar]:	140
	Please note:	stronger bearing
	Center distance [mm]:	65
8 030 45 272	Angle-mill- and drill holder ER 25 AX UT	
	Weight [kg]:	5.470
	Notation:	180° reversible
	Tool drive:	Flat (~DIN 1809)
	Shank size [mm]:	45.00
	Shank type:	BMT
	Tool adaption:	ER 25 A - u-tec



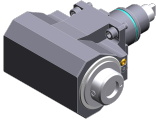
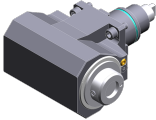

Part-#	Name	
	Gear ratio [i]:	1:1
	Torque max [Nm]:	50
	Rotation max [1/min]:	8000
	Rotating direction:	opposite
	Coolant:	EXT
	Please note:	Combi bearing
	Center distance [mm]:	65
8 030 45 273	Angle-mill- and drill holder ER 25 AX UT IC	
	Weight [kg]:	5.690
	Notation:	180° reversible
	Tool drive:	Flat (~DIN 1809)
	Shank size [mm]:	45.00
	Shank type:	BMT
	Tool adaption:	ER 25 A - u-tec
	Gear ratio [i]:	1:1
	Torque max [Nm]:	50
	Rotation max [1/min]:	6000
	Rotating direction:	opposite
	Coolant:	IC/Ext
	Pressure max [bar]:	140
	Please note:	Combi bearing
	Center distance [mm]:	65
8 030 45 551	Radial drilling and milling head ER 25 AX UT IC	
	Weight [kg]:	6.660
	Notation:	180° reversible
	Tool drive:	Flat (~DIN 1809)
	Shank size [mm]:	45.00
	Shank type:	BMT
	Tool adaption:	ER 25 A - u-tec
	Gear ratio [i]:	1:1
	Torque max [Nm]:	50
	Rotation max [1/min]:	6000
	Rotating direction:	opposite
	Coolant:	IC/Ext
	Pressure max [bar]:	140
	Please note:	Combi bearing
	Center distance [mm]:	105
8 030 45 594	Radial drilling and milling head ER 25 AX UT	
	Weight [kg]:	5.030
	Notation:	180° reversible
	Tool drive:	Flat (~DIN 1809)
	Shank size [mm]:	45.00
	Shank type:	BMT
	Tool adaption:	ER 25 A - u-tec
	Gear ratio [i]:	1:1
	Torque max [Nm]:	50
	Rotation max [1/min]:	12000
	Rotating direction:	opposite
	Coolant:	EXT
	Center distance [mm]:	65

Part-#	Name				
8 030 45 595 	Radial drilling and milling head ER 25 AX UT IC	Weight [kg]: 5.980 Notation: 180° reversible Tool drive: Flat (~DIN 1809) Shank size [mm]: 45.00 Shank type: BMT Tool adaption: ER 25 A - u-tec Gear ratio [i]: 1:1 Torque max [Nm]: 50 Rotation max [1/min]: 12000 Rotating direction: opposite Coolant: IC/Ext Pressure max [bar]: 140 Center distance [mm]: 65			
	8 030 46 459 	Radial drilling and milling head HT 4 IC	Weight [kg]: 5.770 Notation: 180° reversible Tool drive: Flat (~DIN 1809) Shank size [mm]: 45.00 Shank type: BMT Tool adaption: HT 4 Gear ratio [i]: 1:1 Torque max [Nm]: 50 Rotation max [1/min]: 10000 Rotating direction: opposite Coolant: IC/Ext Pressure max [bar]: 140 Center distance [mm]: 65		
		8 030 46 460 	Radial drilling and milling head HT 4	Weight [kg]: 5.530 Notation: 180° reversible Tool drive: Flat (~DIN 1809) Shank size [mm]: 45.00 Shank type: BMT Tool adaption: HT 4 Gear ratio [i]: 1:1 Torque max [Nm]: 50 Rotation max [1/min]: 8000 Rotating direction: opposite Coolant: EXT Please note: stronger bearing Center distance [mm]: 65	
			8 031 44 051	Radial polygon head arbor 16	Notation: 180° reversible Tool drive: Flat (~DIN 1809) Shank size [mm]: 45.00 Shank type: BMT Tool adaption: Polygon arbor 16 Gear ratio [i]: 1:1 Torque max [Nm]: 50 Rotation max [1/min]: 6000 Rotating direction: opposite Coolant: EXT Please note: Combi bearing

Part-#	Name	
	Center distance [mm]:	65
8 033 45 052	Radial drilling and milling head ER 25 AX UT	
	Weight [kg]:	8.180
	Notation:	offset
	Employment for:	Sub spindle
	Tool drive:	Flat (~DIN 1809)
	Shank size [mm]:	45.00
	Shank type:	BMT
	Tool adaption:	ER 25 A - u-tec
	Gear ratio [i]:	1:1
	Torque max [Nm]:	50
	Rotation max [1/min]:	8000
	Rotating direction:	same
	Coolant:	EXT
	Please note:	stronger bearing;
	Center distance [mm]:	80
8 037 44 016	Radial disk mill head arbor 16	
	Notation:	180° reversible
	Version:	± 23° turnable
	Tool drive:	Flat (~DIN 1809)
	Shank size [mm]:	45.00
	Shank type:	BMT
	Tool adaption:	Arbor 16
	Gear ratio [i]:	2:1
	Torque max [Nm]:	32
	Rotation max [1/min]:	4000
	Rotating direction:	opposite
	Coolant:	EXT
	Center distance [mm]:	78
8 037 44 038	Radial disk mill head arbor 16	
	Weight [kg]:	4.650
	Notation:	180° reversible
	Version:	± 45° turnable
	Tool drive:	Flat (~DIN 1809)
	Shank size [mm]:	45.00
	Shank type:	BMT
	Tool adaption:	Arbor 16
	Gear ratio [i]:	2:1
	Torque max [Nm]:	32
	Rotation max [1/min]:	4000
	Rotating direction:	opposite
	Coolant:	EXT
	Center distance [mm]:	78
8 039 45 078	Radial drilling and milling head ER 25 AX UT	
	Weight [kg]:	5.730
	Notation:	180° reversible
	Employment for:	Main- and sub spindle
	Version:	double spindle
	Tool drive:	Flat (~DIN 1809)
	Shank size [mm]:	45.00
	Shank type:	BMT
	Tool adaption:	ER 25 A - u-tec
	Gear ratio [i]:	1:1

Part-#	Name	
	Torque max [Nm]:	50
	Rotation max [1/min]:	8000
	Rotating direction:	same/opposite
	Coolant:	EXT
	Please note:	stronger bearing
	Center distance [mm]:	65
8 039 46 076	Radial drilling and milling head HT 4	
	Weight [kg]:	6.200
	Notation:	180° reversible
	Employment for:	Main- and sub spindle
	Version:	double spindle
	Tool drive:	Flat (~DIN 1809)
	Shank size [mm]:	45.00
	Shank type:	BMT
	Tool adaption:	HT 4
	Gear ratio [i]:	1:1
	Torque max [Nm]:	50
	Rotation max [1/min]:	8000
	Rotating direction:	same/opposite
	Coolant:	EXT
	Please note:	stronger bearing
	Center distance [mm]:	65
8 043 44 014	Universal head +135°/-30° adj. ER16AX UTIK	
	Notation:	offset
	Tool drive:	Flat (~DIN 1809)
	Shank size [mm]:	45.00
	Shank type:	BMT
	Tool adaption:	ER 16 A - u-tec
	Gear ratio [i]:	1:1
	Torque max [Nm]:	25
	Rotation max [1/min]:	6000
	Rotating direction:	opposite
	Coolant:	IC/Ext
	Pressure max [bar]:	140
	Center distance [mm]:	69
	Offset [mm]:	60
8 043 44 015	Universal head +135°/-30° adj. ER16 AX UT	
	Weight [kg]:	8.710
	Notation:	offset
	Tool drive:	Flat (~DIN 1809)
	Shank size [mm]:	45.00
	Shank type:	BMT
	Tool adaption:	ER 16 A - u-tec
	Gear ratio [i]:	1:1
	Torque max [Nm]:	25
	Rotation max [1/min]:	6000
	Rotating direction:	opposite
	Coolant:	EXT
	Center distance [mm]:	69
	Offset [mm]:	60



Part-#	Name		
	8 043 44 043	Universal head +105°/-20° adj. ER16 AX UT	
		Weight [kg]:	5.320
		Notation:	offset;180° reversible
		Tool drive:	Flat (~DIN 1809)
		Shank size [mm]:	45.00
		Shank type:	BMT
		Tool adaption:	ER 16 A - u-tec
		Gear ratio [i]:	1:1
		Torque max [Nm]:	25
		Rotation max [1/min]:	6000
		Rotating direction:	opposite
		Coolant:	EXT
		Center distance [mm]:	50
	Offset [mm]:	35	
	8 043 45 011	Universal head +135°/-30° adj. ER25AX UT	
		Weight [kg]:	8.950
		Notation:	offset
		Tool drive:	Flat (~DIN 1809)
		Shank size [mm]:	45.00
		Shank type:	BMT
		Tool adaption:	ER 25 A - u-tec
		Gear ratio [i]:	1:1
		Torque max [Nm]:	25
		Rotation max [1/min]:	6000
		Rotating direction:	same
		Coolant:	EXT
		Please note:	Note swivel range! stronger bearing
	Center distance [mm]:	69	
	Offset [mm]:	60	
	8 043 45 016	Universal head +135°/-30° adj. ER25AX UT	
		Weight [kg]:	8.920
		Notation:	offset
		Version:	at 45° position can be pinned
		Tool drive:	Flat (~DIN 1809)
		Shank size [mm]:	45.00
		Shank type:	BMT
		Tool adaption:	ER 25 A - u-tec
		Gear ratio [i]:	1:1
		Torque max [Nm]:	25
		Rotation max [1/min]:	6000
		Rotating direction:	same
		Coolant:	EXT
	Please note:	Note swivel range! stronger bearing	
	Center distance [mm]:	69	
	Offset [mm]:	60	
	8 050 44 030	Multispindle drilling head ER 16 AX UT	
		Weight [kg]:	5.000
		Notation:	offset
		Employment for:	Main spindle
		Version:	2-spindles
		Tool drive:	Flat (~DIN 1809)
		Shank size [mm]:	45.00
		Shank type:	BMT
		Tool adaption:	ER 16 A - u-tec



Part-#	Name	
	Gear ratio [i]:	1:1
	Torque max [Nm]:	25
	Rotation max [1/min]:	6000
	Rotating direction:	same
	Coolant:	EXT
	Offset [mm]:	58
8 053 44 051	Multispindle radial head ER 16 AX UT	
	Weight [kg]:	6.540
	Notation:	180° reversible
	Version:	2-spindles
	Tool drive:	Flat (~DIN 1809)
	Shank size [mm]:	45.00
	Shank type:	BMT
	Tool adaption:	ER 16 A - u-tec
	Gear ratio [i]:	1:1
	Torque max [Nm]:	25
	Rotation max [1/min]:	6000
	Rotating direction:	same
	Coolant:	EXT
	Please note:	Check applicability; note tool length!
	Center distance [mm]:	85
8 200 99 000	Cover plate 75,0x 75,0x 5,0	
	Weight [kg]:	0.480
	Shank size [mm]:	45.00
	Shank type:	BMT
8 202 00 011	Basic holder longitudinal seat FN 12	
	Weight [kg]:	0.700
	Notation:	180° reversible
	Shank type:	BMT
	Machine adaption:	Centering key b 15
	Tool adaption:	Interface FN 12
	Coolant:	EXT
	Center distance [mm]:	15
8 224 02 003	Cut-off holder SH 26	
	Weight [kg]:	1.190
	Notation:	180° reversible
	Employment for:	Cut-off tool 26
	Version:	Clampshaft on turret side
	Shank type:	BMT
	Machine adaption:	Centering key b 15
	Tool adaption:	Clampshaft SH 26
	Coolant:	EXT
8 224 03 011	Cut-off holder SH 32	
	Weight [kg]:	1.230
	Notation:	180° reversible
	Employment for:	Cut-off tool 32
	Version:	Clampshaft on turret side
	Shank type:	BMT
	Machine adaption:	Centering key b 15
	Tool adaption:	Clampshaft SH 32
	Coolant:	EXT

Part-#	Name	
8 224 04 051	Universal turning holder sq. 3/4"	
	Weight [kg]:	2.450
	Notation:	180° reversible
	Shank type:	BMT
	Machine adaption:	Centering key b 15
	Tool adaption:	Sq. 3/4" (19,05mm)
	Coolant:	EXT
8 224 04 076	Universal turning holder sq. 20 IC	
	Notation:	180° reversible
	Shank type:	BMT
	Machine adaption:	Centering key b 15
	Tool adaption:	Sq. 20
		Sq. 20
	Coolant:	IC/Ext
	Pressure max [bar]:	140
	Please note:	Key rail
8 240 05 006	Collet chuck holder ER 25	
	Weight [kg]:	3.090
	Notation:	180° reversible
	Shank type:	BMT
	Machine adaption:	Centering key b 15
	Tool adaption:	ER 25
	Coolant:	IC/Ext
	Pressure max [bar]:	80
	Center distance [mm]:	85
8 240 05 038	Collet chuck holder ER 25 AX UT	
	Weight [kg]:	3.090
	Notation:	180° reversible
	Shank type:	BMT
	Machine adaption:	Centering key b 15
	Tool adaption:	ER 25 A - u-tec
	Coolant:	IC/Ext
	Center distance [mm]:	85
8 240 05 058	Tool holder ABS 50 IC/Ext	
	Weight [kg]:	4.340
	Notation:	offset
	Shank type:	BMT
	Machine adaption:	Centering key b 15
	Tool adaption:	ABS 50
	Coolant:	IC/Ext
	Center distance [mm]:	85
8 240 05 064	Boring bar holder Ø 16	
	Notation:	180° reversible
	Shank type:	BMT
	Machine adaption:	Centering key b 15
	Tool adaption:	Ø 16
	Coolant:	IC/Ext
	Center distance [mm]:	85



Part-#	Name	
8 240 06 013	Collet chuck holder ER 32	
	Weight [kg]:	3.220
	Notation:	180° reversible
	Shank type:	BMT
	Machine adaption:	Centering key b 15
	Tool adaption:	ER 32
	Coolant:	IC/Ext
	Pressure max [bar]:	80
	Center distance [mm]:	85
8 240 06 014	Tool holder HT 4 IC	
	Weight [kg]:	3.070
	Notation:	180° reversible
	Shank type:	BMT
	Machine adaption:	Centering key b 15
	Tool adaption:	HT 4
	Coolant:	IC/Ext
	Center distance [mm]:	85
8 240 06 048	Tool holder C 4 IC	
	Weight [kg]:	4.640
	Notation:	180° reversible
	Version:	offset
	Shank type:	BMT
	Machine adaption:	Centering key b 15
	Tool adaption:	heimatec Capto(TM) C 4
	Coolant:	IC
	Center distance [mm]:	85
8 240 06 055	Boring bar holder Ø 20	
	Weight [kg]:	4.180
	Notation:	180° reversible
	Shank type:	BMT
	Machine adaption:	Centering key b 15
	Tool adaption:	Ø 20
	Coolant:	IC/Ext
	Center distance [mm]:	85
8 240 07 005	Boring bar holder Ø 1"	
	Weight [kg]:	3.490
	Notation:	180° reversible
	Shank type:	BMT
	Machine adaption:	Centering key b 15
	Tool adaption:	Ø 1" (25,4mm)
	Coolant:	IC/Ext
	Center distance [mm]:	65
8 240 07 010	Boring bar holder Ø 1 1/4"	
	Weight [kg]:	3.320
	Notation:	180° reversible
	Shank type:	BMT
	Machine adaption:	Centering key b 15
	Tool adaption:	Ø 1 1/4" (31,75mm)
	Coolant:	IC/Ext
	Pressure max [bar]:	140
	Center distance [mm]:	65

Part-#	Name	
8 240 07 015	Boring bar holder Ø 1 1/4"	
	Weight [kg]:	3.750
	Notation:	180° reversible
	Shank type:	BMT
	Machine adaption:	Centering key b 15
	Tool adaption:	Ø 1 1/4" (31,75mm)
	Coolant:	IC/Ext
	Center distance [mm]:	85
8 240 07 018	Boring bar holder Ø 25	
	Weight [kg]:	4.000
	Notation:	180° reversible
	Shank type:	BMT
	Machine adaption:	Centering key b 15
	Tool adaption:	Ø 25
	Coolant:	IC/Ext
	Center distance [mm]:	85
8 240 07 019	Boring bar holder Ø 1"	
	Notation:	180° reversible
	Shank type:	BMT
	Machine adaption:	Centering key b 15
	Tool adaption:	Ø 1" (25,4mm)
	Coolant:	IC/Ext
	Center distance [mm]:	85
8 240 07 039	Boring bar holder Ø 25	
	Weight [kg]:	3.520
	Notation:	180° reversible
	Shank type:	BMT
	Machine adaption:	Centering key b 15
	Tool adaption:	Ø 25
	Coolant:	IC/Ext
	Center distance [mm]:	65
8 240 07 042	Tool holder HT 5 IC	
	Weight [kg]:	3.100
	Notation:	180° reversible
	Shank type:	BMT
	Machine adaption:	Centering key b 15
	Tool adaption:	HT 5
	Coolant:	IC/Ext
	Center distance [mm]:	85
8 240 08 003	Boring bar holder Ø 32	
	Weight [kg]:	3.320
	Notation:	180° reversible
	Shank type:	BMT
	Machine adaption:	Centering key b 15
	Tool adaption:	Ø 32
	Coolant:	IC/Ext
	Pressure max [bar]:	80
	Center distance [mm]:	65

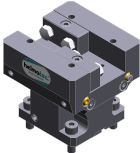

Part-#	Name	
8 240 08 016	Boring bar holder Ø 1 1/2"	
	Weight [kg]:	3.130
	Notation:	180° reversible
	Shank type:	BMT
	Machine adaption:	Centering key b 15
	Tool adaption:	Ø 1 1/2" (38,1mm)
	Coolant:	IC/Ext
	Center distance [mm]:	65
8 240 08 017	Boring bar holder Ø 32	
	Notation:	180° reversible
	Shank type:	BMT
	Machine adaption:	Centering key b 15
	Tool adaption:	Ø 32
	Coolant:	IC/Ext
	Pressure max [bar]:	80
	Center distance [mm]:	80
8 240 08 018	Boring bar holder Ø 1 1/2"	
	Weight [kg]:	3.700
	Notation:	180° reversible
	Shank type:	BMT
	Machine adaption:	Centering key b 15
	Tool adaption:	Ø 1 1/2" (38,1mm)
	Coolant:	IC/Ext
	Center distance [mm]:	80
8 240 08 021	Boring bar holder Ø 32	
	Weight [kg]:	3.780
	Notation:	180° reversible
	Shank type:	BMT
	Machine adaption:	Centering key b 15
	Tool adaption:	Ø 32
	Coolant:	IC/Ext
	Pressure max [bar]:	80
	Center distance [mm]:	85
8 240 08 022	Boring bar holder Ø 1 1/2"	
	Notation:	180° reversible
	Shank type:	BMT
	Machine adaption:	Centering key b 15
	Tool adaption:	Ø 1 1/2" (38,1mm)
	Coolant:	IC/Ext
	Center distance [mm]:	85
8 240 08 047	Boring bar holder Ø 32	
	Weight [kg]:	4.020
	Notation:	180° reversible
	Version:	offset
	Shank type:	BMT
	Machine adaption:	Centering key b 15
	Tool adaption:	Ø 32
	Coolant:	IC/Ext
	Pressure max [bar]:	80
	Center distance [mm]:	85



Part-#	Name	
8 240 08 057	Boring bar holder Ø 32	
	Weight [kg]:	3.890
	Notation:	180° reversible
	Version:	offset
	Shank type:	BMT
	Machine adaption:	Centering key b 15
	Tool adaption:	Ø 32
	Coolant:	IC/Ext
	Pressure max [bar]:	80
	Center distance [mm]:	85
8 240 09 014	Boring bar holder Ø 40	
	Notation:	180° reversible
	Shank type:	BMT
	Machine adaption:	Centering key b 15
	Tool adaption:	Ø 40
	Coolant:	IC/Ext
	Pressure max [bar]:	80
	Center distance [mm]:	65
8 240 09 015	Boring bar holder Ø 40	
	Notation:	180° reversible
	Shank type:	BMT
	Machine adaption:	Centering key b 15
	Tool adaption:	Ø 40
	Coolant:	IC/Ext
	Pressure max [bar]:	80
	Center distance [mm]:	80
8 240 09 017	Boring bar holder Ø 40	
	Weight [kg]:	3.600
	Notation:	180° reversible
	Shank type:	BMT
	Machine adaption:	Centering key b 15
	Tool adaption:	Ø 40
	Coolant:	IC/Ext
	Center distance [mm]:	85
8 240 09 059	Boring bar holder Ø 50	
	Weight [kg]:	3.160
	Notation:	180° reversible
	Shank type:	BMT
	Machine adaption:	Centering key b 15
	Tool adaption:	Ø 50
	Coolant:	EXT
	Center distance [mm]:	65
8 244 04 000	Combi facing holder sq. 20	
	Weight [kg]:	3.930
	Employment for:	Main- and sub spindle
	Shank type:	BMT
	Machine adaption:	Centering key b 15
	Tool adaption:	Sq. 20
	Coolant:	EXT
	Pressure max [bar]:	80

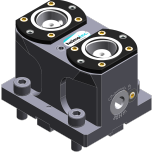
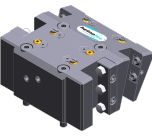

Part-#	Name	
8 244 04 007	Combi facing holder sq. 3/4"	
	Employment for:	Main- and sub spindle
	Shank type:	BMT
	Machine adaption:	Centering key b 15
	Tool adaption:	Sq. 3/4" (19,05mm)
	Coolant:	EXT
8 244 04 022	Combi facing holder sq. 20 IC	
	Weight [kg]:	2.200
	Employment for:	Main- and sub spindle
	Shank type:	BMT
	Machine adaption:	Centering key b 15
	Tool adaption:	Sq. 20
	Coolant:	IC/Ext
	Pressure max [bar]:	100
	Please note:	Key rail
8 244 04 029	Combi facing holder sq. 20 IC	
	Employment for:	Main- and sub spindle
	Shank type:	BMT
	Machine adaption:	Centering key b 15
	Tool adaption:	Sq. 20
	Coolant:	IC/Ext
	Pressure max [bar]:	100
8 244 05 009	Combi facing holder sq. 25	
	Weight [kg]:	4.320
	Employment for:	Main- and sub spindle
	Version:	Special
	Shank type:	BMT
	Machine adaption:	Centering key b 15
	Tool adaption:	Sq. 25
	Coolant:	EXT
8 249 05 000	Double collet chuck holder ER 25	
	Weight [kg]:	3.370
	Notation:	180° reversible
	Employment for:	Main- and sub spindle
	Shank type:	BMT
	Machine adaption:	Centering key b 15
	Tool adaption:	ER 25
		ER 25
	Coolant:	IC/Ext
	Pressure max [bar]:	80
	Center distance [mm]:	85
8 249 05 007	Double collet chuck holder ER 25 AX UT	
	Weight [kg]:	3.370
	Notation:	180° reversible
	Employment for:	Main- and sub spindle
	Shank type:	BMT
	Machine adaption:	Centering key b 15
	Tool adaption:	ER 25 A - u-tec
		ER 25 A - u-tec
	Coolant:	IC/Ext
	Center distance [mm]:	85

Part-#	Name	
8 249 06 002	Double collet chuck holder ER 32	
	Weight [kg]:	3.590
	Notation:	180° reversible
	Employment for:	Main- and sub spindle
	Shank type:	BMT
	Machine adaption:	Centering key b 15
	Tool adaption:	ER 32
		ER 32
	Coolant:	IC/Ext
	Pressure max [bar]:	80
	Center distance [mm]:	85
8 249 06 003	Double tool holder HT 4	
	Weight [kg]:	3.300
	Notation:	180° reversible
	Employment for:	Main- and sub spindle
	Shank type:	BMT
	Machine adaption:	Centering key b 15
	Tool adaption:	HT 4
		HT 4
	Coolant:	IC/Ext
	Center distance [mm]:	85
8 249 07 001	Double boring bar holder Ø 1 1/4"	
	Weight [kg]:	3.730
	Notation:	180° reversible
	Employment for:	Main- and sub spindle
	Shank type:	BMT
	Machine adaption:	Centering key b 15
	Tool adaption:	Ø 1 1/4" (31,75mm)
	Coolant:	IC/Ext
	Center distance [mm]:	85
8 249 07 004	Double boring bar holder Ø 25	
	Weight [kg]:	3.690
	Notation:	180° reversible
	Employment for:	Main- and sub spindle
	Shank type:	BMT
	Machine adaption:	Centering key b 15
	Tool adaption:	Ø 25
	Coolant:	IC/Ext
	Center distance [mm]:	85
8 249 08 002	Double boring bar holder Ø 32	
	Weight [kg]:	4.440
	Notation:	offset
	Shank type:	BMT
	Machine adaption:	Centering key b 15
	Tool adaption:	Ø 32
	Coolant:	IC/Ext
	Center distance [mm]:	80

Part-#	Name	
8 249 08 004	Double boring bar holder Ø 32	
	Weight [kg]:	3.540
	Notation:	180° reversible
	Employment for:	Main- and sub spindle
	Shank type:	BMT
	Machine adaption:	Centering key b 15
	Tool adaption:	Ø 32
	Coolant:	IC/Ext
	Center distance [mm]:	85
8 250 05 004	Multiple tool holder C 3 IC	
	Weight [kg]:	2.100
	Employment for:	Main- and sub spindle
	Version:	right
	Shank type:	BMT
	Machine adaption:	Centering key b 15
	Tool adaption:	heimatec Capto(TM) C 3 heimatec Capto(TM) C 3
	Coolant:	IC
	Please note:	Check applicability; note tool length!
	Offset [mm]:	27 27
8 251 04 044	Combi double turning holder sq. 20	
	Weight [kg]:	4.280
	Employment for:	Main- and sub spindle
	Shank type:	BMT
	Machine adaption:	Centering key b 15
	Tool adaption:	Sq. 20 Sq. 20 Sq. 20 Sq. 20
	Coolant:	EXT
8 251 04 045	Combi multiple holder 6x sq. 20	
	Weight [kg]:	5.270
	Employment for:	Main- and sub spindle
	Shank type:	BMT
	Machine adaption:	Centering key b 15
	Tool adaption:	Sq. 20 Sq. 20 Sq. 20 Sq. 20
	Coolant:	EXT
	Pressure max [bar]:	80
8 251 04 046	Combi multiple holder sq. 3/4"	
	Weight [kg]:	5.310
	Employment for:	Main- and sub spindle
	Shank type:	BMT
	Machine adaption:	Centering key b 15
	Tool adaption:	Sq. 3/4" (19,05mm) Sq. 3/4" (19,05mm) Sq. 3/4" (19,05mm) Sq. 3/4" (19,05mm)
	Coolant:	EXT

Part-#	Name	
8 251 04 047	Combi double turning holder sq. 3/4"	
	Employment for:	Main- and sub spindle
	Shank type:	BMT
	Machine adaption:	Centering key b 15
	Tool adaption:	Sq. 3/4" (19,05mm)
		Sq. 3/4" (19,05mm)
		Sq. 3/4" (19,05mm)
		Sq. 3/4" (19,05mm)
	Coolant:	EXT
8 253 05 000	Multiple boring bar holder Ø 3/4"	
	Weight [kg]:	3.320
	Notation:	180° reversible
	Shank type:	BMT
	Machine adaption:	Centering key b 15
	Tool adaption:	Ø 3/4" (19,05mm)
		Ø 3/4" (19,05mm)
	Coolant:	IC/Ext
	Center distance [mm]:	55/90
8 253 05 002	Double boring bar holder Ø 3/4"	
	Weight [kg]:	3.460
	Notation:	180° reversible
	Shank type:	BMT
	Machine adaption:	Centering key b 15
	Tool adaption:	Ø 3/4" (19,05mm)
		Ø 3/4" (19,05mm)
	Coolant:	IC/Ext
	Center distance [mm]:	65/90
8 253 06 004	Double boring bar holder Ø 20	
	Notation:	180° reversible
	Shank type:	BMT
	Machine adaption:	Centering key b 15
	Tool adaption:	Ø 20
		Ø 20
	Coolant:	IC/Ext
	Pressure max [bar]:	80
	Center distance [mm]:	65/90
8 253 07 012	Double boring bar holder Ø 25	
	Weight [kg]:	3.150
	Notation:	180° reversible
	Shank type:	BMT
	Machine adaption:	Centering key b 15
	Tool adaption:	Ø 25
		Ø 25
	Coolant:	IC/Ext
	Pressure max [bar]:	80
	Center distance [mm]:	55/90

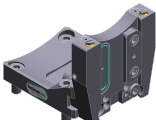
Part-#	Name	
8 253 07 030	Multiple boring bar holder Ø 1"	
	Weight [kg]:	5.940
	Shank type:	BMT
	Machine adaption:	Centering key b 15
	Tool adaption:	Ø 1" Ø 1" - 15°
	Coolant:	IC/Ext
	Center distance [mm]:	85
8 253 07 034	Multiple boring bar holder Ø 25	
	Weight [kg]:	2.330
	Notation:	180° reversible
	Version:	offset
	Shank type:	BMT
	Machine adaption:	Centering key b 15
	Tool adaption:	Ø 25 Ø 25
	Coolant:	IC/Ext
	Please note:	Use necessarily check; note tool length
	Center distance [mm]:	55/100
8 253 08 010	Multiple boring bar holder Ø 32	
	Weight [kg]:	3.500
	Notation:	180° reversible
	Shank type:	BMT
	Machine adaption:	Centering key b 15
	Tool adaption:	Ø 32 Ø 32
	Coolant:	IC/Ext
	Please note:	Use püfen; note tool length!
	Center distance [mm]:	65/100
8 259 01 015	Multiple turning holder 4x sq. 20	
	Weight [kg]:	5.320
	Employment for:	Main- and sub spindle
	Version:	Y-axes offset
	Shank type:	BMT
	Machine adaption:	Centering key b 15
	Tool adaption:	Sq. 20 Sq. 20 Sq. 20 Sq. 20
	Coolant:	EXT
8 259 01 016	Multiple turning holder 4x sq. 20 IC	
	Weight [kg]:	5.300
	Employment for:	Main- and sub spindle
	Version:	Y-axes offset
	Shank type:	BMT
	Machine adaption:	Centering key b 15
	Tool adaption:	Sq. 20 Sq. 20 Sq. 20 Sq. 20
	Coolant:	IC/Ext
	Pressure max [bar]:	100

Part-#	Name	
8 320 02 012	Cut-off holder, height adjustable SH 26 IC	
	Weight [kg]:	1.270
	Notation:	180° reversible
	Shank type:	BMT
	Machine adaption:	Centering key b 15
	Tool adaption:	Clampshaft SH 26
	Coolant:	IC/Ext
	Pressure max [bar]:	70
8 320 02 013	Cut-off holder, height adjustable SH 26 IC	
	Weight [kg]:	1.360
	Notation:	180° reversible
	Shank type:	BMT
	Machine adaption:	Centering key b 15
	Tool adaption:	Clampshaft SH 26
	Coolant:	IC/Ext
	Pressure max [bar]:	70
	Please note:	Clampshaft internal
8 320 03 011	Cut-off holder, height adjustable SH 32 IC	
	Weight [kg]:	1.330
	Notation:	180° reversible
	Shank type:	BMT
	Machine adaption:	Centering key b 15
	Tool adaption:	Clampshaft SH 32
	Coolant:	IC/Ext
	Pressure max [bar]:	70
8 320 03 018	Cut-off holder, height adjustable SH 32 IC	
	Weight [kg]:	1.480
	Notation:	180° reversible
	Shank type:	BMT
	Machine adaption:	Centering key b 15
	Tool adaption:	Clampshaft SH 32
	Coolant:	IC/Ext
	Pressure max [bar]:	70
	Please note:	Clampshaft internal
8 320 03 023	Cut-off holder, height adjustable SH 32 IC	
	Weight [kg]:	1.590
	Shank type:	BMT
	Machine adaption:	Centering key b 15
	Tool adaption:	Clampshaft SH 32
	Coolant:	IC/Ext
	Pressure max [bar]:	70
	Please note:	with offset cut-off tool holder; use
8 320 03 051	Cut-off holder, height adjustable SH 32 IC	
	Weight [kg]:	1.230
	Notation:	180° reversible
	Version:	Clampshaft on turret center
	Shank type:	BMT
	Machine adaption:	Centering key b 15
	Tool adaption:	Clampshaft SH 32
	Coolant:	IC/Ext
	Pressure max [bar]:	70

Doosan

Lynx 2100 LMSA/LMSB BMT 45

heimatec®

Part-#	Name	
8 710 94 005	Mounting device BMT 45 Spinner	
	Weight [kg]:	10.040
	Tool adaption:	BMT 45

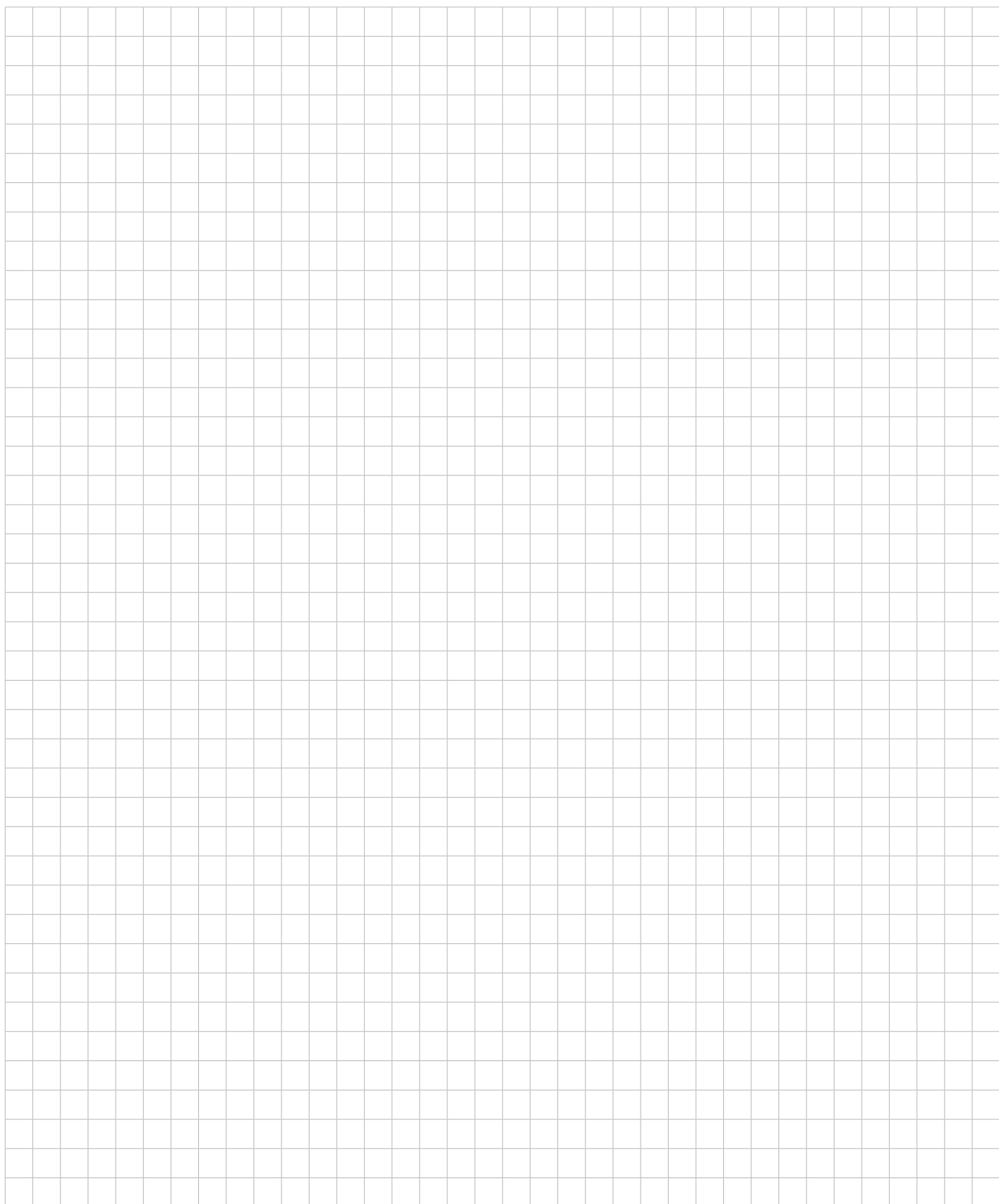

heimatec.u-tec®

heimatec.com

Products / Tool change systems /
u-tec® Tool-changing system



versions see catalog



heimatec.easy-quick

heimatec.com

Products / Tool change systems /
easy-quick HT quick-changing system



versions see catalog



heimatec.Capto™

heimatec.com

Products / Tool change systems /
heimatec.Capto™ quick-changing system



versions see catalog

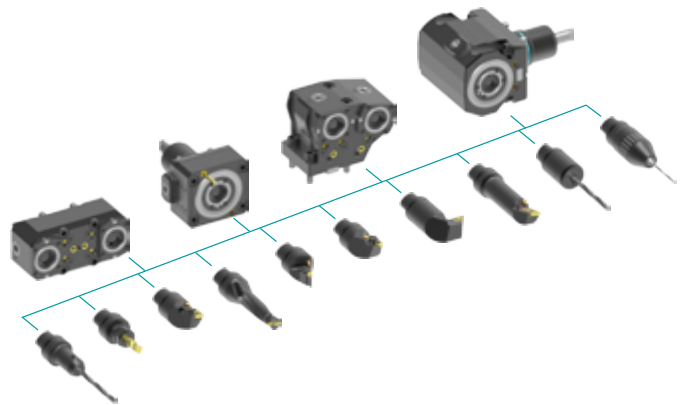

heimatec.accessories

heimatec.com

Products / Accessories



versions see catalog





● heimatec overseas branches

○ global representations of heimatec

heimatec[®]

heimatec GmbH
Präzisionswerkzeuge
Carl-Benz-Str. 4
77871 Renchen
Germany

T +49 7843 9466 0
www.heimatec.com
info@heimatec.com

Please find the contact details of our worldwide trading partners on our website:
<https://heimatec.com/business-partners>