

Mazak

QT Nexus 250
M/MS/MY/MSY -
16 Stationen



High-tech from heimatec - heimatec - Tools and systems for productive turning and milling

heimatec belongs to the international technology and quality leaders for precision tools and specializes in the development and production of high-precision static and live tools for all CNC lathes, CNC turn-/mill machines and CNC machining centers.

The range of products* spans from static BMT and VDI tool holders, live tools up to highly complex customer-specific individual solutions. heimatec, headquartered in Renchen, has a own subsidiary in Asia and India and numerous representatives as well as trading partners all over the world.

*OUR PRODCUTS

Static tool holders

Live tool units

Precision tools

Tools for turning and machining centres

Tools for swiss type lathes

Tool changing and uick-change systems

Tool systems for gear production

Digital tool management

This catalogue, including all its parts, is protected by copyright. Any use outside the restricted limitations of the Copyright Act without the consent of heimatec is inadmissible and liable to prosecution. This applies in particular to duplication, translation, microfilming and storage and processing in electronic systems.

heimatec GmbH reserves the right to make technical changes at any time without giving prior notice. This applies in particular to adjustments at any time to meet new or changed international standards, or in case of further developments of our products or manufacturing processes.

The current version of our General Terms and Conditions can be found on our website.

QT Nexus 250 M/MS/MY/MSY - 16 Stationen

Part-#	Name	
8 010 45 117	Axial drilling and milling head ER 25 AX UT	
	Weight [kg]:	3.220
	Tool drive:	Flat (~DIN 1809)
	Shank size [mm]:	40.00
	Shank type:	VDI
	Tool adaption:	ER 25 A - u-tec
	Gear ratio [i]:	1:1
	Torque max [Nm]:	50
	Rotation max [1/min]:	6000
	Rotating direction:	same
	Coolant:	EXT
8 010 45 140	Axial drilling and milling head ER 25 AX UT IC	
	Weight [kg]:	3.260
	Tool drive:	Flat (~DIN 1809)
	Shank size [mm]:	40.00
	Shank type:	VDI
	Tool adaption:	ER 25 A - u-tec
	Gear ratio [i]:	1:1
	Torque max [Nm]:	50
	Rotation max [1/min]:	6000
	Rotating direction:	same
	Coolant:	IC/Ext
	Pressure max [bar]:	25
8 010 46 082	Axial drilling and milling head HT 4	
	Weight [kg]:	3.300
	Tool drive:	Flat (~DIN 1809)
	Shank size [mm]:	40.00
	Shank type:	VDI
	Tool adaption:	HT 4
	Gear ratio [i]:	1:1
	Torque max [Nm]:	50
	Rotation max [1/min]:	6000
	Rotating direction:	same
	Coolant:	EXT
8 011 45 005	Axial milling head universal arbor 22	
	Weight [kg]:	3.460
	Tool drive:	Flat (~DIN 1809)
	Shank size [mm]:	40.00
	Shank type:	VDI
	Tool adaption:	Universal arbor 22
	Gear ratio [i]:	1:1
	Torque max [Nm]:	50
	Rotation max [1/min]:	6000
	Rotating direction:	same
	Coolant:	EXT
8 019 44 009	Axial milling head universal arbor 16 IC	
	Weight [kg]:	5.840
	Notation:	offset
	Tool drive:	Flat (~DIN 1809)
	Shank size [mm]:	40.00
	Shank type:	VDI
	Tool adaption:	Universal arbor 16
	Gear ratio [i]:	2:1
	Torque max [Nm]:	80

QT Nexus 250 M/MS/MY/MSY - 16 Stationen

Part-#	Name	
	Rotation max [1/min]:	3000
	Rotating direction:	same
	Coolant:	IC/Ext
	Offset [mm]:	50
8 019 45 028	Axial drilling and milling head ER 25 AX UT	
	Notation:	offset
	Tool drive:	Flat (~DIN 1809)
	Shank size [mm]:	40.00
	Shank type:	VDI
	Tool adaption:	ER 25 A - u-tec
	Gear ratio [i]:	1:2
	Torque max [Nm]:	40
	Rotation max [1/min]:	12000
	Rotating direction:	opposite
	Coolant:	EXT
	Offset [mm]:	50
8 019 45 039	Axial milling head universal arbor 22	
	Notation:	offset
	Tool drive:	Flat (~DIN 1809)
	Shank size [mm]:	40.00
	Shank type:	VDI
	Tool adaption:	Universal arbor 22
	Gear ratio [i]:	2:1
	Torque max [Nm]:	80
	Rotation max [1/min]:	3000
	Rotating direction:	opposite
	Coolant:	EXT
	Please note:	stronger bearing
	Offset [mm]:	50
8 019 45 115	Axial drilling and milling head ER 25 AX UT	
	Weight [kg]:	5.530
	Notation:	offset
	Tool drive:	Flat (~DIN 1809)
	Shank size [mm]:	40.00
	Shank type:	VDI
	Tool adaption:	ER 25 A - u-tec
	Gear ratio [i]:	1:1
	Torque max [Nm]:	50
	Rotation max [1/min]:	6000
	Rotating direction:	opposite
	Coolant:	EXT
	Please note:	stronger bearing
	Offset [mm]:	50
8 019 45 116	Axial drilling and milling head ER 25 AX UT IC	
	Weight [kg]:	5.720
	Notation:	offset
	Tool drive:	Flat (~DIN 1809)
	Shank size [mm]:	40.00
	Shank type:	VDI
	Tool adaption:	ER 25 A - u-tec
	Gear ratio [i]:	1:1
	Torque max [Nm]:	50
	Rotation max [1/min]:	6000
	Rotating direction:	opposite

QT Nexus 250 M/MS/MY/MSY - 16 Stationen

Part-#	Name	
	Coolant:	IC/Ext
	Pressure max [bar]:	140
	Please note:	stronger bearing
	Offset [mm]:	50
8 019 45 119	Axial drilling and milling head ER 25 AX UT	
	Weight [kg]:	6.630
	Notation:	offset
	Employment for:	Sub spindle
	Tool drive:	Flat (~DIN 1809)
	Shank size [mm]:	40.00
	Shank type:	VDI
	Tool adaption:	ER 25 A - u-tec
	Gear ratio [i]:	1:1
	Torque max [Nm]:	50
	Rotation max [1/min]:	6000
	Rotating direction:	opposite
	Coolant:	EXT
	Please note:	stronger bearing
	Offset [mm]:	50
8 019 45 124	Axial drilling and milling head ER 25 AX UT IC	
	Weight [kg]:	6.720
	Notation:	offset
	Employment for:	Sub spindle
	Tool drive:	Flat (~DIN 1809)
	Shank size [mm]:	40.00
	Shank type:	VDI
	Tool adaption:	ER 25 A - u-tec
	Gear ratio [i]:	1:1
	Torque max [Nm]:	50
	Rotation max [1/min]:	6000
	Rotating direction:	opposite
	Coolant:	IC/Ext
	Pressure max [bar]:	140
	Please note:	stronger bearing
	Offset [mm]:	50
8 019 45 146	Axial drilling and milling head ER 25 AX UT	
	Weight [kg]:	7.530
	Notation:	offset
	Tool drive:	Flat (~DIN 1809)
	Shank size [mm]:	40.00
	Shank type:	VDI
	Tool adaption:	ER 25 A - u-tec
	Gear ratio [i]:	1:3
	Torque max [Nm]:	16
	Rotation max [1/min]:	15000
	Rotating direction:	opposite
	Coolant:	EXT
	Offset [mm]:	50

QT Nexus 250 M/MS/MY/MSY - 16 Stationen

Part-#	Name	
8 019 45 177	Axial drilling and milling head ER 25	
	Weight [kg]:	5.720
	Notation:	offset
	Tool drive:	Flat (~DIN 1809)
	Shank size [mm]:	40.00
	Shank type:	VDI
	Tool adaption:	ER 25
	Gear ratio [i]:	1:1
	Torque max [Nm]:	50
	Rotation max [1/min]:	6000
	Rotating direction:	opposite
	Coolant:	EXT
	Please note:	stronger bearing
	Offset [mm]:	50
8 019 46 032	Axial drilling and milling head HT 4	
	Weight [kg]:	5.100
	Notation:	offset
	Tool drive:	Flat (~DIN 1809)
	Shank size [mm]:	40.00
	Shank type:	VDI
	Tool adaption:	HT 4
	Gear ratio [i]:	1:1
	Torque max [Nm]:	50
	Rotation max [1/min]:	6000
	Rotating direction:	opposite
	Coolant:	EXT
	Offset [mm]:	50
8 019 46 058	Axial drilling and milling head HT 4 IC	
	Weight [kg]:	5.390
	Notation:	offset
	Tool drive:	Flat (~DIN 1809)
	Shank size [mm]:	40.00
	Shank type:	VDI
	Tool adaption:	HT 4
	Gear ratio [i]:	1:1
	Torque max [Nm]:	50
	Rotation max [1/min]:	6000
	Rotating direction:	opposite
	Coolant:	IC/Ext
	Pressure max [bar]:	140
	Offset [mm]:	50
8 019 46 059	Axial drilling and milling head HT 4	
	Weight [kg]:	6.000
	Notation:	offset
	Tool drive:	Flat (~DIN 1809)
	Shank size [mm]:	40.00
	Shank type:	VDI
	Tool adaption:	HT 4
	Gear ratio [i]:	1:2
	Torque max [Nm]:	25
	Rotation max [1/min]:	12000
	Rotating direction:	opposite
	Coolant:	EXT
	Offset [mm]:	50

QT Nexus 250 M/MS/MY/MSY - 16 Stationen

Part-#	Name
8 019 46 060	Axial drilling and milling head ER 32 AX UT IC
	Weight [kg]: 5.680
	Notation: offset
	Tool drive: Flat (~DIN 1809)
	Shank size [mm]: 40.00
	Shank type: VDI
	Tool adaption: ER 32 A - u-tec
	Gear ratio [i]: 1:1
	Torque max [Nm]: 50
	Rotation max [1/min]: 6000
	Rotating direction: opposite
	Coolant: IC/Ext
	Pressure max [bar]: 140
	Please note: stronger bearing
8 019 46 101	Axial drilling and milling head ER 32 AX UT IC
	Weight [kg]: 7.130
	Notation: offset
	Tool drive: Flat (~DIN 1809)
	Shank size [mm]: 40.00
	Shank type: VDI
	Tool adaption: ER 32 A - u-tec
	Gear ratio [i]: 1:2
	Torque max [Nm]: 40
	Rotation max [1/min]: 12000
	Rotating direction: opposite
	Coolant: IC/Ext
	Pressure max [bar]: 140
	Offset [mm]: 50
8 019 46 108	Axial drilling and milling head ER 32 AX UT
	Weight [kg]: 5.500
	Notation: offset
	Tool drive: Flat (~DIN 1809)
	Shank size [mm]: 40.00
	Shank type: VDI
	Tool adaption: ER 32 A - u-tec
	Gear ratio [i]: 1:1
	Torque max [Nm]: 50
	Rotation max [1/min]: 6000
	Rotating direction: opposite
	Coolant: EXT
	Please note: stronger bearing
	Offset [mm]: 50
8 019 46 120	Axial drilling and milling head ER 32 AX UT IC
	Weight [kg]: 6.680
	Notation: offset
	Employment for: Sub spindle
	Tool drive: Flat (~DIN 1809)
	Shank size [mm]: 40.00
	Shank type: VDI
	Tool adaption: ER 32 A - u-tec
	Gear ratio [i]: 1:1
	Torque max [Nm]: 50
	Rotation max [1/min]: 6000
	Rotating direction: opposite
	Coolant: IC/Ext

QT Nexus 250 M/MS/MY/MSY - 16 Stationen

Part-#	Name	
	Pressure max [bar]:	140
	Please note:	stronger bearing
	Offset [mm]:	50
8 019 47 036	Axial drilling and milling head HT 5	
	Notation:	offset
	Tool drive:	Flat (~DIN 1809)
	Shank size [mm]:	40.00
	Shank type:	VDI
	Tool adaption:	HT 5
	Gear ratio [i]:	1:1
	Torque max [Nm]:	50
	Rotation max [1/min]:	6000
	Rotating direction:	opposite
	Coolant:	EXT
	Offset [mm]:	50
8 019 47 037	Axial drilling and milling head HT 5 IC	
	Notation:	offset
	Tool drive:	Flat (~DIN 1809)
	Shank size [mm]:	40.00
	Shank type:	VDI
	Tool adaption:	HT 5
	Gear ratio [i]:	1:1
	Torque max [Nm]:	50
	Rotation max [1/min]:	6000
	Rotating direction:	opposite
	Coolant:	IC/Ext
	Pressure max [bar]:	140
	Offset [mm]:	50
8 030 45 042	Radial drilling and milling head ER 25 AX IC	
	Weight [kg]:	7.400
	Employment for:	Sub spindle
	Tool drive:	Flat (~DIN 1809)
	Shank size [mm]:	40.00
	Shank type:	VDI
	Tool adaption:	ER 25
	Gear ratio [i]:	1:1
	Torque max [Nm]:	50
	Rotation max [1/min]:	6000
	Rotating direction:	opposite
	Coolant:	IC/Ext
	Pressure max [bar]:	25
	Center distance [mm]:	100
8 030 45 047	Radial drilling and milling head ER 25	
	Weight [kg]:	7.340
	Employment for:	Main spindle
	Tool drive:	Flat (~DIN 1809)
	Shank size [mm]:	40.00
	Shank type:	VDI
	Tool adaption:	ER 25
	Gear ratio [i]:	1:2
	Torque max [Nm]:	16
	Rotation max [1/min]:	12000
	Rotating direction:	opposite
	Coolant:	EXT

QT Nexus 250 M/MS/MY/MSY - 16 Stationen

Part-#	Name	
	Center distance [mm]:	100
8 030 45 051	Radial drilling and milling head ER 25	
	Tool drive:	Flat (~DIN 1809)
	Shank size [mm]:	40.00
	Shank type:	VDI
	Tool adaption:	ER 25
	Gear ratio [i]:	1:3
	Torque max [Nm]:	15
	Rotation max [1/min]:	18000
	Rotating direction:	opposite
	Coolant:	EXT
8 030 45 069	Radial drilling and milling head ER 25	
	Weight [kg]:	6.880
	Employment for:	Main spindle
	Tool drive:	Flat (~DIN 1809)
	Shank size [mm]:	40.00
	Shank type:	VDI
	Tool adaption:	ER 25
	Gear ratio [i]:	1:1
	Torque max [Nm]:	50
	Rotation max [1/min]:	6000
	Rotating direction:	opposite
	Coolant:	EXT
	Center distance [mm]:	100
8 030 45 070	Radial drilling and milling head ER 25 IC	
	Employment for:	Main spindle
	Tool drive:	Flat (~DIN 1809)
	Shank size [mm]:	40.00
	Shank type:	VDI
	Tool adaption:	ER 25
	Gear ratio [i]:	1:1
	Torque max [Nm]:	50
	Rotation max [1/min]:	6000
	Rotating direction:	opposite
	Coolant:	IC/Ext
	Pressure max [bar]:	140
	Center distance [mm]:	100
8 030 45 102	Radial drilling and milling head ER 25 IC	
	Weight [kg]:	7.640
	Tool drive:	Flat (~DIN 1809)
	Shank size [mm]:	40.00
	Shank type:	VDI
	Tool adaption:	ER 25
	Gear ratio [i]:	1:2
	Torque max [Nm]:	16
	Rotation max [1/min]:	12000
	Rotating direction:	opposite
	Coolant:	IC/Ext
	Pressure max [bar]:	140
	Center distance [mm]:	100

QT Nexus 250 M/MS/MY/MSY - 16 Stationen

Part-#	Name	
8 030 45 183	Radial drilling and milling head ER 25 AX UT	
	Weight [kg]:	6.770
	Employment for:	Main spindle
	Tool drive:	Flat (~DIN 1809)
	Shank size [mm]:	40.00
	Shank type:	VDI
	Tool adaption:	ER 25 A - u-tec
	Gear ratio [i]:	1:1
	Torque max [Nm]:	50
	Rotation max [1/min]:	6000
	Rotating direction:	opposite
	Coolant:	EXT
	Center distance [mm]:	100
8 030 45 184	Radial drilling and milling head ER 25 AX UT IC	
	Weight [kg]:	7.320
	Employment for:	Main spindle
	Tool drive:	Flat (~DIN 1809)
	Shank size [mm]:	40.00
	Shank type:	VDI
	Tool adaption:	ER 25 A - u-tec
	Gear ratio [i]:	1:1
	Torque max [Nm]:	50
	Rotation max [1/min]:	6000
	Rotating direction:	opposite
	Coolant:	IC/Ext
	Pressure max [bar]:	140
	Center distance [mm]:	100
8 030 45 213	Radial drilling and milling head ER 25 AX UT	
	Weight [kg]:	6.820
	Employment for:	Main spindle
	Tool drive:	Flat (~DIN 1809)
	Shank size [mm]:	40.00
	Shank type:	VDI
	Tool adaption:	ER 25 A - u-tec
	Gear ratio [i]:	2:1
	Torque max [Nm]:	63
	Rotation max [1/min]:	4000
	Rotating direction:	opposite
	Coolant:	EXT
	Center distance [mm]:	100
8 030 45 234	Radial drilling and milling head ER 25 AX UT IC	
	Weight [kg]:	8.340
	Tool drive:	Flat (~DIN 1809)
	Shank size [mm]:	40.00
	Shank type:	VDI
	Tool adaption:	ER 25 A - u-tec
	Gear ratio [i]:	1:2
	Torque max [Nm]:	16
	Rotation max [1/min]:	12000
	Rotating direction:	opposite
	Coolant:	IC/Ext
	Pressure max [bar]:	140
	Please note:	stronger bearing
	Center distance [mm]:	100

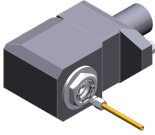
Part-#	Name	
8 030 45 297	Radial drilling and milling head ER 25 AX UT IC	
	Weight [kg]:	7.230
	Employment for:	Sub spindle
	Tool drive:	Flat (~DIN 1809)
	Shank size [mm]:	40.00
	Shank type:	VDI
	Tool adaption:	ER 25 A - u-tec
	Gear ratio [i]:	1:1
	Torque max [Nm]:	50
	Rotation max [1/min]:	6000
	Rotating direction:	opposite
	Coolant:	IC/Ext
	Pressure max [bar]:	140
	Center distance [mm]:	100
8 030 45 298	Radial drilling and milling head ER 25 AX UT	
	Employment for:	Sub spindle
	Tool drive:	Flat (~DIN 1809)
	Shank size [mm]:	40.00
	Shank type:	VDI
	Tool adaption:	ER 25 A - u-tec
	Gear ratio [i]:	1:1
	Torque max [Nm]:	50
	Rotation max [1/min]:	6000
	Rotating direction:	opposite
	Coolant:	EXT
	Center distance [mm]:	100
8 030 45 313	Radial drilling and milling head ER 25 AX UT	
	Weight [kg]:	7.990
	Tool drive:	Flat (~DIN 1809)
	Shank size [mm]:	40.00
	Shank type:	VDI
	Tool adaption:	ER 25 A - u-tec
	Gear ratio [i]:	1:2
	Torque max [Nm]:	16
	Rotation max [1/min]:	12000
	Rotating direction:	opposite
	Coolant:	EXT
	Please note:	stronger bearing
	Center distance [mm]:	100
8 030 46 067	Radial drilling and milling head ER 32 IC	
	Weight [kg]:	7.800
	Employment for:	Main spindle
	Tool drive:	Flat (~DIN 1809)
	Shank size [mm]:	40.00
	Shank type:	VDI
	Tool adaption:	ER 32
	Gear ratio [i]:	1:1
	Torque max [Nm]:	50
	Rotation max [1/min]:	6000
	Rotating direction:	opposite
	Coolant:	IC/Ext
	Pressure max [bar]:	25
	Center distance [mm]:	100

QT Nexus 250 M/MS/MY/MSY - 16 Stationen

Part-#	Name	
8 030 46 112	Radial drilling and milling head HT 4	
	Weight [kg]:	6.880
	Employment for:	Main spindle
	Tool drive:	Flat (~DIN 1809)
	Shank size [mm]:	40.00
	Shank type:	VDI
	Tool adaption:	HT 4
	Gear ratio [i]:	1:1
	Torque max [Nm]:	50
	Rotation max [1/min]:	6000
	Rotating direction:	opposite
	Coolant:	EXT
	Center distance [mm]:	100
8 030 46 165	Radial drilling and milling head ER 32 AX UT IC	
	Weight [kg]:	8.690
	Tool drive:	Flat (~DIN 1809)
	Shank size [mm]:	40.00
	Shank type:	VDI
	Tool adaption:	ER 32 A - u-tec
	Gear ratio [i]:	1:2
	Torque max [Nm]:	16
	Rotation max [1/min]:	12000
	Rotating direction:	opposite
	Coolant:	IC/Ext
	Pressure max [bar]:	140
	Please note:	stronger bearing
	Center distance [mm]:	100
8 030 46 176	Radial drilling and milling head HT 4 IC	
	Weight [kg]:	7.390
	Employment for:	Main spindle
	Tool drive:	Flat (~DIN 1809)
	Shank size [mm]:	40.00
	Shank type:	VDI
	Tool adaption:	HT 4
	Gear ratio [i]:	1:1
	Torque max [Nm]:	50
	Rotation max [1/min]:	6000
	Rotating direction:	opposite
	Coolant:	IC/Ext
	Pressure max [bar]:	140
	Center distance [mm]:	100
8 030 46 180	Radial drilling and milling head HT 4 IC	
	Tool drive:	Flat (~DIN 1809)
	Shank size [mm]:	40.00
	Shank type:	VDI
	Tool adaption:	HT 4
	Gear ratio [i]:	1:2
	Torque max [Nm]:	16
	Rotation max [1/min]:	12000
	Rotating direction:	opposite
	Coolant:	IC/Ext
	Pressure max [bar]:	140
	Center distance [mm]:	100

QT Nexus 250 M/MS/MY/MSY - 16 Stationen

Part-#	Name	
8 030 46 312	Radial drilling and milling head ER 32 AX UT	
	Weight [kg]:	6.730
	Employment for:	Main spindle
	Tool drive:	Flat (~DIN 1809)
	Shank size [mm]:	40.00
	Shank type:	VDI
	Tool adaption:	ER 32 A - u-tec
	Gear ratio [i]:	1:1
	Torque max [Nm]:	50
	Rotation max [1/min]:	6000
	Rotating direction:	opposite
	Coolant:	EXT
	Center distance [mm]:	100
8 030 46 313	Radial drilling and milling head ER 32 AX UT IC	
	Weight [kg]:	7.350
	Employment for:	Main spindle
	Tool drive:	Flat (~DIN 1809)
	Shank size [mm]:	40.00
	Shank type:	VDI
	Tool adaption:	ER 32 A - u-tec
	Gear ratio [i]:	1:1
	Torque max [Nm]:	50
	Rotation max [1/min]:	6000
	Rotating direction:	opposite
	Coolant:	IC/Ext
	Pressure max [bar]:	140
	Center distance [mm]:	100
8 031 44 018	Radial milling head universal arbor 16	
	Employment for:	Main spindle
	Tool drive:	Flat (~DIN 1809)
	Shank size [mm]:	40.00
	Shank type:	VDI
	Tool adaption:	Universal arbor 16
	Gear ratio [i]:	1:1
	Torque max [Nm]:	50
	Rotation max [1/min]:	6000
	Rotating direction:	opposite
	Coolant:	EXT
	Center distance [mm]:	100
8 031 45 005	Radial milling head universal arbor 22	
	Employment for:	Main spindle
	Tool drive:	Flat (~DIN 1809)
	Shank size [mm]:	40.00
	Shank type:	VDI
	Tool adaption:	Universal arbor 22
	Gear ratio [i]:	1:1
	Torque max [Nm]:	50
	Rotation max [1/min]:	6000
	Rotating direction:	opposite
	Coolant:	EXT
	Center distance [mm]:	100

QT Nexus 250 M/MS/MY/MSY - 16 Stationen

Part-#	Name	
8 031 45 009	Radial milling head universal arbor 22	
	Employment for:	Main spindle
	Tool drive:	Flat (~DIN 1809)
	Shank size [mm]:	40.00
	Shank type:	VDI
	Tool adaption:	Universal arbor 22
	Gear ratio [i]:	2:1
	Torque max [Nm]:	63
	Rotation max [1/min]:	4000
	Rotating direction:	opposite
	Coolant:	EXT
	Center distance [mm]:	100
8 033 46 071	Radial drilling and milling head HT 4	
	Weight [kg]:	8.480
	Notation:	offset
	Employment for:	Sub spindle
	Tool drive:	Flat (~DIN 1809)
	Shank size [mm]:	40.00
	Shank type:	VDI
	Tool adaption:	HT 4
	Gear ratio [i]:	1:2
	Torque max [Nm]:	16
	Rotation max [1/min]:	12000
	Rotating direction:	same
	Coolant:	EXT
	Center distance [mm]:	100
8 033 46 073	Radial drilling and milling head HT 4 IC	
	Notation:	offset
	Employment for:	Sub spindle
	Tool drive:	Flat (~DIN 1809)
	Shank size [mm]:	40.00
	Shank type:	VDI
	Tool adaption:	HT 4
	Gear ratio [i]:	1:2
	Torque max [Nm]:	16
	Rotation max [1/min]:	12000
	Rotating direction:	same
	Coolant:	IC/Ext
	Pressure max [bar]:	25
	Center distance [mm]:	100
8 033 46 142	Radial drilling and milling head ER 32 AX UT IC	
	Notation:	offset
	Employment for:	Sub spindle
	Tool drive:	Flat (~DIN 1809)
	Shank size [mm]:	40.00
	Shank type:	VDI
	Tool adaption:	ER 32 A - u-tec
	Gear ratio [i]:	1:2
	Torque max [Nm]:	16
	Rotation max [1/min]:	12000
	Rotating direction:	same
	Coolant:	IC/Ext
	Pressure max [bar]:	140
	Please note:	stronger bearing
	Center distance [mm]:	100

QT Nexus 250 M/MS/MY/MSY - 16 Stationen

Part-#	Name	
8 037 45 005	Woodruff keycutter ER 25 AX	
	Weight [kg]:	7.080
	Tool drive:	Flat (~DIN 1809)
	Shank size [mm]:	40.00
	Shank type:	VDI
	Tool adaption:	ER 25 A
	Gear ratio [i]:	1333:1
	Torque max [Nm]:	32
	Rotation max [1/min]:	4000
	Rotating direction:	opposite
	Coolant:	EXT
8 037 49 010	Radial disk mill head shaft diameter 10-25,4	
	Weight [kg]:	6.000
	Tool drive:	Flat (~DIN 1809)
	Shank size [mm]:	40.00
	Shank type:	VDI
	Tool adaption:	Interchangeable arbor
	Gear ratio [i]:	2,541:1
	Torque max [Nm]:	40
	Rotation max [1/min]:	2400
	Rotating direction:	opposite
	Coolant:	EXT
	Please note:	Price without arbor
	Center distance [mm]:	96,5
8 038 45 004	Radial drilling and milling head ER 25	
	Weight [kg]:	5.320
	Notation:	Y-axes adjustable
	Employment for:	Sub spindle
	Tool drive:	Flat (~DIN 1809)
	Shank size [mm]:	40.00
	Shank type:	VDI
	Tool adaption:	ER 25
	Gear ratio [i]:	1:1
	Torque max [Nm]:	25
	Rotation max [1/min]:	6000
	Rotating direction:	same
	Coolant:	EXT
8 039 45 011	Radial drilling and milling head ER 25 AX UT	
	Weight [kg]:	7.490
	Employment for:	Main- and sub spindle
	Version:	double spindle
	Tool drive:	Flat (~DIN 1809)
	Shank size [mm]:	40.00
	Shank type:	VDI
	Tool adaption:	ER 25 A - u-tec ER 25 A - u-tec
	Gear ratio [i]:	1:1
	Torque max [Nm]:	50
	Rotation max [1/min]:	6000
	Rotating direction:	same/opposite
	Coolant:	EXT
	Center distance [mm]:	100

QT Nexus 250 M/MS/MY/MSY - 16 Stationen

Part-#	Name	
8 039 45 014	Radial drilling and milling head ER 25 AX	
	Weight [kg]:	8.420
	Employment for:	Main- and sub spindle
	Version:	double spindle
	Tool drive:	Flat (~DIN 1809)
	Shank size [mm]:	40.00
	Shank type:	VDI
	Tool adaption:	ER 25 A
	Gear ratio [i]:	1:3
	Torque max [Nm]:	12
	Rotation max [1/min]:	18000
	Rotating direction:	same/opposite
	Coolant:	EXT
	Please note:	Special version
	Center distance [mm]:	100
8 039 45 015	Radial drilling and milling head ER 25 AX UT	
	Notation:	double spindle
	Employment for:	Main- and sub spindle
	Version:	Special
	Tool drive:	Flat (~DIN 1809)
	Shank size [mm]:	40.00
	Shank type:	VDI
	Tool adaption:	ER 25 A - u-tec
	Gear ratio [i]:	1:2
	Torque max [Nm]:	25
	Rotation max [1/min]:	12000
	Rotating direction:	same/opposite
	Coolant:	EXT
	Center distance [mm]:	100
8 039 45 082	Radial drilling and milling head ER 25 AX UT	
	Weight [kg]:	6.640
	Notation:	9° angle
	Tool drive:	Flat (~DIN 1809)
	Shank size [mm]:	40.00
	Shank type:	VDI
	Tool adaption:	ER 25 A - u-tec
	Gear ratio [i]:	1:1
	Torque max [Nm]:	50
	Rotation max [1/min]:	6000
	Rotating direction:	opposite
	Coolant:	EXT
8 039 46 020	Radial drilling and milling head ER 32 AX UT	
	Weight [kg]:	7.600
	Employment for:	Main- and sub spindle
	Version:	double spindle
	Tool drive:	Flat (~DIN 1809)
	Shank size [mm]:	40.00
	Shank type:	VDI
	Tool adaption:	ER 32 A - u-tec
	Gear ratio [i]:	1:1
	Torque max [Nm]:	50
	Rotation max [1/min]:	6000
	Rotating direction:	same/opposite
	Coolant:	EXT
	Center distance [mm]:	100

QT Nexus 250 M/MS/MY/MSY - 16 Stationen

Part-#	Name	
8 040 44 039	Universal head $\pm 90^\circ$ adjustable ER 16 AX UT	
	Tool drive:	Flat (~DIN 1809)
	Shank size [mm]:	40.00
	Shank type:	VDI
	Tool adaption:	ER 16 A - u-tec
	Gear ratio [i]:	1:2
	Torque max [Nm]:	12
	Rotation max [1/min]:	12000
	Rotating direction:	opposite
	Coolant:	EXT
	Please note:	Note swivel range
	Center distance [mm]:	87
8 040 44 052	Universal head $\pm 90^\circ$ adjustable ER 16 AX UT	
	Weight [kg]:	5.080
	Tool drive:	Flat (~DIN 1809)
	Shank size [mm]:	40.00
	Shank type:	VDI
	Tool adaption:	ER 16 A - u-tec
	Gear ratio [i]:	1:1
	Torque max [Nm]:	25
	Rotation max [1/min]:	6000
	Rotating direction:	opposite
	Coolant:	EXT
	Please note:	Note swivel range
	Center distance [mm]:	87
8 040 44 057	Universal head $\pm 90^\circ$ adjustable ER 16 AX UT IC	
	Weight [kg]:	5.150
	Tool drive:	Flat (~DIN 1809)
	Shank size [mm]:	40.00
	Shank type:	VDI
	Tool adaption:	ER 16 A - u-tec
	Gear ratio [i]:	1:1
	Torque max [Nm]:	25
	Rotation max [1/min]:	6000
	Rotating direction:	opposite
	Coolant:	IC/Ext
	Pressure max [bar]:	140
	Please note:	Note swivel range
	Center distance [mm]:	87
8 040 45 076	Universal head $\pm 90^\circ$ adjustable ER 25 AX UT IC	
	Weight [kg]:	5.340
	Tool drive:	Flat (~DIN 1809)
	Shank size [mm]:	40.00
	Shank type:	VDI
	Tool adaption:	ER 25 A - u-tec
	Gear ratio [i]:	1:1
	Torque max [Nm]:	25
	Rotation max [1/min]:	6000
	Rotating direction:	opposite
	Coolant:	IC/Ext
	Pressure max [bar]:	140
	Please note:	stronger bearing
	Center distance [mm]:	87

QT Nexus 250 M/MS/MY/MSY - 16 Stationen

Part-#	Name	
8 040 45 079	Universal head ± 90° adjustable ER 25 AX UT	
	Weight [kg]:	5.320
	Tool drive:	Flat (~DIN 1809)
	Shank size [mm]:	40.00
	Shank type:	VDI
	Tool adaption:	ER 25 A - u-tec
	Gear ratio [i]:	1:1
	Torque max [Nm]:	25
	Rotation max [1/min]:	6000
	Rotating direction:	opposite
	Coolant:	EXT
	Please note:	stronger bearing
	Center distance [mm]:	87
8 050 44 037	Multispindle drilling head ER 20 AX UT	
	Notation:	offset
	Version:	2-spindles
	Tool drive:	Flat (~DIN 1809)
	Shank size [mm]:	40.00
	Shank type:	VDI
	Tool adaption:	ER 20 A - u-tec
	Gear ratio [i]:	1:1
	Torque max [Nm]:	25/SP.
	Rotation max [1/min]:	6000
	Rotating direction:	opposite
	Coolant:	EXT
	Offset [mm]:	± 30
8 050 45 029	Multispindle drilling head ER 25 AX UT	
	Weight [kg]:	5.200
	Notation:	offset
	Version:	2-spindles
	Tool drive:	Flat (~DIN 1809)
	Shank size [mm]:	40.00
	Shank type:	VDI
	Tool adaption:	ER 25 A - u-tec
	Gear ratio [i]:	1:1
	Torque max [Nm]:	32
	Rotation max [1/min]:	6000
	Rotating direction:	opposite
	Coolant:	EXT
	Please note:	stronger bearing
8 200 41 000	Plug Ø 40x60	
	Weight [kg]:	1.140
	Shank size [mm]:	40.00
	Shank type:	VDI
8 202 40 002	Basic holder for height adjustable adapter	
	Weight [kg]:	3.340
	Shank size [mm]:	40.00
	Shank type:	VDI
	Coolant:	EXT

QT Nexus 250 M/MS/MY/MSY - 16 Stationen

Part-#	Name	
8 202 40 005	Basic holder for height adjustable adapter	
	Weight [kg]:	3.300
	Employment for:	Sub spindle
	Shank size [mm]:	40.00
	Shank type:	VDI
	Coolant:	EXT
8 202 40 008	Basic holder longitudinal seat FN 12	
	Weight [kg]:	3.250
	Shank size [mm]:	40.00
	Shank type:	VDI
	Tool adaption:	Interface FN 12
	Coolant:	EXT
	Center distance [mm]:	40
8 214 43 003	Cut-off holder SH 32	
	Version:	Clampshaft on turret center
	Shank size [mm]:	40.00
	Shank type:	VDI
	Tool adaption:	Clampshaft SH 32
	Coolant:	EXT
	Please note:	demountalbe clampshaft
8 214 43 007	Cut-off holder SH 32	
	Weight [kg]:	3.580
	Version:	Clampshaft on turret side
	Shank size [mm]:	40.00
	Shank type:	VDI
	Tool adaption:	Clampshaft SH 32
	Coolant:	EXT
	Please note:	demountalbe clampshaft
8 214 43 013	Cut-off holder SH 32	
	Weight [kg]:	3.470
	Employment for:	Cut-off tool 32
	Version:	Clampshaft on turret center
	Shank size [mm]:	40.00
	Shank type:	VDI
	Tool adaption:	Clampshaft SH 32
	Coolant:	EXT
	Please note:	demountalbe clampshaft
8 214 43 014	Cut-off holder SH 32	
	Weight [kg]:	3.470
	Employment for:	Cut-off tool 32
	Version:	Clampshaft on turret side
	Shank size [mm]:	40.00
	Shank type:	VDI
	Tool adaption:	Clampshaft SH 32
	Coolant:	EXT
	Please note:	demountalbe clampshaft

QT Nexus 250 M/MS/MY/MSY - 16 Stationen

Part-#	Name	
8 214 43 018	Cut-off holder SH 32	
	Employment for:	Cut-off tool 32
	Version:	Special
	Shank size [mm]:	40.00
	Shank type:	VDI
	Tool adaption:	Clampshaft SH 32
	Coolant:	EXT
	Please note:	demountalbe clampshaft
8 214 44 001	Universal turning holder sq. 20	
	Weight [kg]:	5.460
	Shank size [mm]:	40.00
	Shank type:	VDI
	Tool adaption:	Sq. 20
	Coolant:	EXT
8 214 44 003	Universal turning holder sq. 20	
	Weight [kg]:	5.320
	Employment for:	Sub spindle
	Shank size [mm]:	40.00
	Shank type:	VDI
	Tool adaption:	Sq. 20
	Coolant:	EXT
8 214 45 005	Universal turning holder sq. 25	
	Weight [kg]:	5.180
	Shank size [mm]:	40.00
	Shank type:	VDI
	Tool adaption:	Sq. 25
	Coolant:	EXT
8 230 45 000	Boring bar holder Ø 19	
	Weight [kg]:	7.780
	Employment for:	Main spindle
	Version:	Special
	Shank size [mm]:	40.00
	Shank type:	VDI
	Tool adaption:	Ø 19
	Coolant:	IC/Ext
	Please note:	Offset dimension to center 56 mm
	Center distance [mm]:	110
8 230 45 001	Collet chuck holder ER 25	
	Weight [kg]:	6.780
	Employment for:	Main spindle
	Shank size [mm]:	40.00
	Shank type:	VDI
	Tool adaption:	ER 25
	Coolant:	IC/Ext
	Please note:	Front edge clamping nut max. 91 mm
	Center distance [mm]:	110

QT Nexus 250 M/MS/MY/MSY - 16 Stationen

Part-#	Name	
8 230 46 002	Boring bar holder Ø 20	
	Weight [kg]:	5.260
	Notation:	offset
	Employment for:	Sub spindle
	Shank size [mm]:	40.00
	Shank type:	VDI
	Tool adaption:	Ø 20
	Coolant:	IC/Ext
	Please note:	Offset dimension to center 10 mm
	Center distance [mm]:	120
8 230 47 009	Boring bar holder Ø 31,6	
	Employment for:	Main spindle
	Version:	Special
	Shank size [mm]:	40.00
	Shank type:	VDI
	Tool adaption:	Ø 31,6
	Coolant:	IC/Ext
	Please note:	Offset dimension to center 56 mm
	Center distance [mm]:	110
8 230 47 014	Boring bar holder Ø 25	
	Weight [kg]:	6.460
	Employment for:	Main spindle
	Shank size [mm]:	40.00
	Shank type:	VDI
	Tool adaption:	Ø 25
	Coolant:	IC/Ext
	Please note:	Offset dimension to center 56 mm
	Center distance [mm]:	110
8 230 48 001	Boring bar holder Ø 32	
	Weight [kg]:	6.260
	Employment for:	Main spindle
	Shank size [mm]:	40.00
	Shank type:	VDI
	Tool adaption:	Ø 32
	Coolant:	IC/Ext
	Please note:	Offset dimension to center 56 mm
	Center distance [mm]:	110
8 230 49 012	Boring bar holder Ø 40	
	Weight [kg]:	6.170
	Employment for:	Main spindle
	Shank size [mm]:	40.00
	Shank type:	VDI
	Tool adaption:	Ø 40
	Coolant:	IC/Ext
	Please note:	Offset dimension to center 56 mm
	Center distance [mm]:	110

QT Nexus 250 M/MS/MY/MSY - 16 Stationen

Part-#	Name	
8 230 49 059	Boring bar holder Ø 40	
	Weight [kg]:	6.640
	Notation:	offset
	Employment for:	Main spindle
	Shank size [mm]:	40.00
	Shank type:	VDI
	Tool adaption:	Ø 40
	Coolant:	IC/Ext
	Please note:	Offset dimension on center
	Center distance [mm]:	110
8 234 44 000	Combi facing holder sq. 20	
	Weight [kg]:	6.700
	Shank size [mm]:	40.00
	Shank type:	VDI
	Tool adaption:	Sq. 20
	Coolant:	EXT
8 234 44 007	Combi facing holder sq. 20	
	Weight [kg]:	6.690
	Employment for:	Main- and sub spindle
	Shank size [mm]:	40.00
	Shank type:	VDI
	Tool adaption:	Sq. 20
	Coolant:	EXT
8 239 45 001	Double collet chuck holder ER 25	
	Weight [kg]:	8.160
	Employment for:	Main- and sub spindle
	Shank size [mm]:	40.00
	Shank type:	VDI
	Tool adaption:	ER 25
	Coolant:	EXT
	Center distance [mm]:	110
8 239 45 002	Double collet chuck holder ER 25	
	Weight [kg]:	8.160
	Employment for:	Main- and sub spindle
	Shank size [mm]:	40.00
	Shank type:	VDI
	Tool adaption:	ER 25
	Coolant:	IC/Ext
	Please note:	Front edge clamping nut max. 86/54 mm
	Center distance [mm]:	110
8 239 46 001	Double boring bar holder Ø 20	
	Weight [kg]:	7.120
	Employment for:	Main- and sub spindle
	Shank size [mm]:	40.00
	Shank type:	VDI
	Tool adaption:	Ø 20
	Coolant:	IC/Ext
	Please note:	Offset dimension to center 60/10 mm
	Center distance [mm]:	110

QT Nexus 250 M/MS/MY/MSY - 16 Stationen

Part-#	Name	
8 239 46 002	Double boring bar holder Ø 20	
	Weight [kg]:	6.020
	Employment for:	Main- and sub spindle
	Shank size [mm]:	40.00
	Shank type:	VDI
	Tool adaption:	Ø 20
	Coolant:	EXT
	Center distance [mm]:	110
8 239 46 005	Double tool holder HT 4	
	Weight [kg]:	6.000
	Employment for:	Main- and sub spindle
	Shank size [mm]:	40.00
	Shank type:	VDI
	Tool adaption:	HT 4
	Coolant:	IC/Ext
	Please note:	Offset dimension to center 60/30 mm
	Center distance [mm]:	110
8 239 46 007	Double collet chuck holder ER 32	
	Weight [kg]:	6.280
	Employment for:	Main- and sub spindle
	Shank size [mm]:	40.00
	Shank type:	VDI
	Tool adaption:	ER 32
	Coolant:	IC/Ext
	Please note:	Front edge clamping nut max 80/50 mm
	Center distance [mm]:	110
8 239 46 031	Double tool holder HT 4	
	Weight [kg]:	6.540
	Employment for:	Main- and sub spindle
	Shank size [mm]:	40.00
	Shank type:	VDI
	Tool adaption:	HT 4
	Coolant:	IC/Ext
	Please note:	Offset dimension to center 80/10 mm
	Center distance [mm]:	110
8 239 47 026	Double boring bar holder Ø 25	
	Weight [kg]:	6.600
	Employment for:	Main- and sub spindle
	Shank size [mm]:	40.00
	Shank type:	VDI
	Tool adaption:	Ø 25
	Coolant:	IC/Ext
	Center distance [mm]:	110
8 239 48 006	Double boring bar holder Ø 32	
	Employment for:	Main- and sub spindle
	Shank size [mm]:	40.00
	Shank type:	VDI
	Tool adaption:	Ø 32
	Coolant:	IC/Ext
	Pressure max [bar]:	100
	Center distance [mm]:	110

QT Nexus 250 M/MS/MY/MSY - 16 Stationen

Part-#	Name	
8 239 49 020	Double boring bar holder Ø 40	
	Weight [kg]:	6.160
	Employment for:	Main- and sub spindle
	Shank size [mm]:	40.00
	Shank type:	VDI
	Tool adaption:	Ø 40
	Coolant:	IC/Ext
	Center distance [mm]:	110
8 251 44 000	Combi double turning holder sq. 20	
	Weight [kg]:	6.200
	Shank size [mm]:	40.00
	Shank type:	VDI
	Tool adaption:	Sq. 20
		Sq. 20
		Sq. 20
		Sq. 20
	Coolant:	EXT
8 320 43 011	Cut-off holder, height adjustable SH 32 IC	
	Weight [kg]:	3.860
	Shank size [mm]:	40.00
	Shank type:	VDI
	Tool adaption:	Clampshaft SH 32
	Coolant:	IC/Ext
	Pressure max [bar]:	70

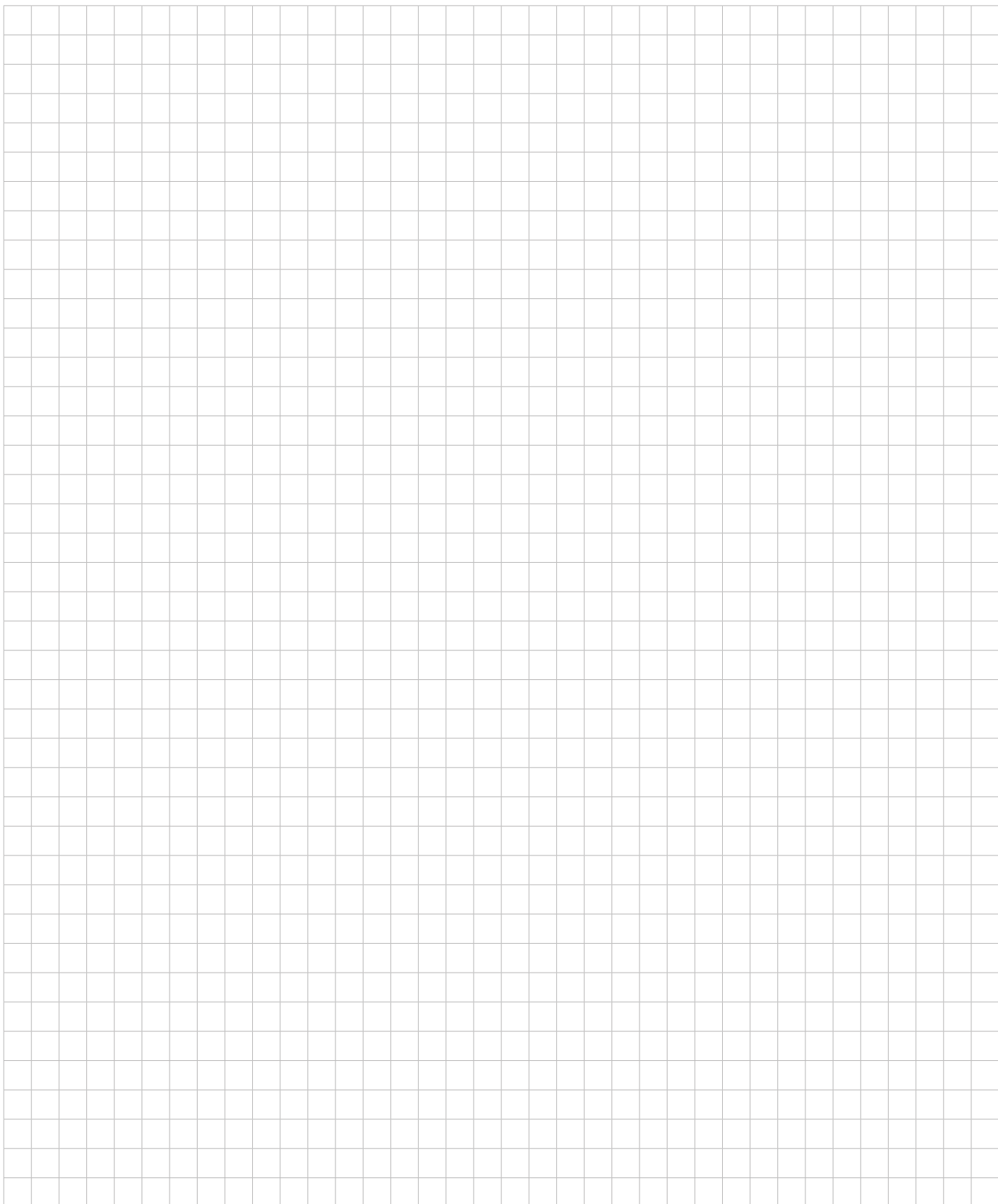

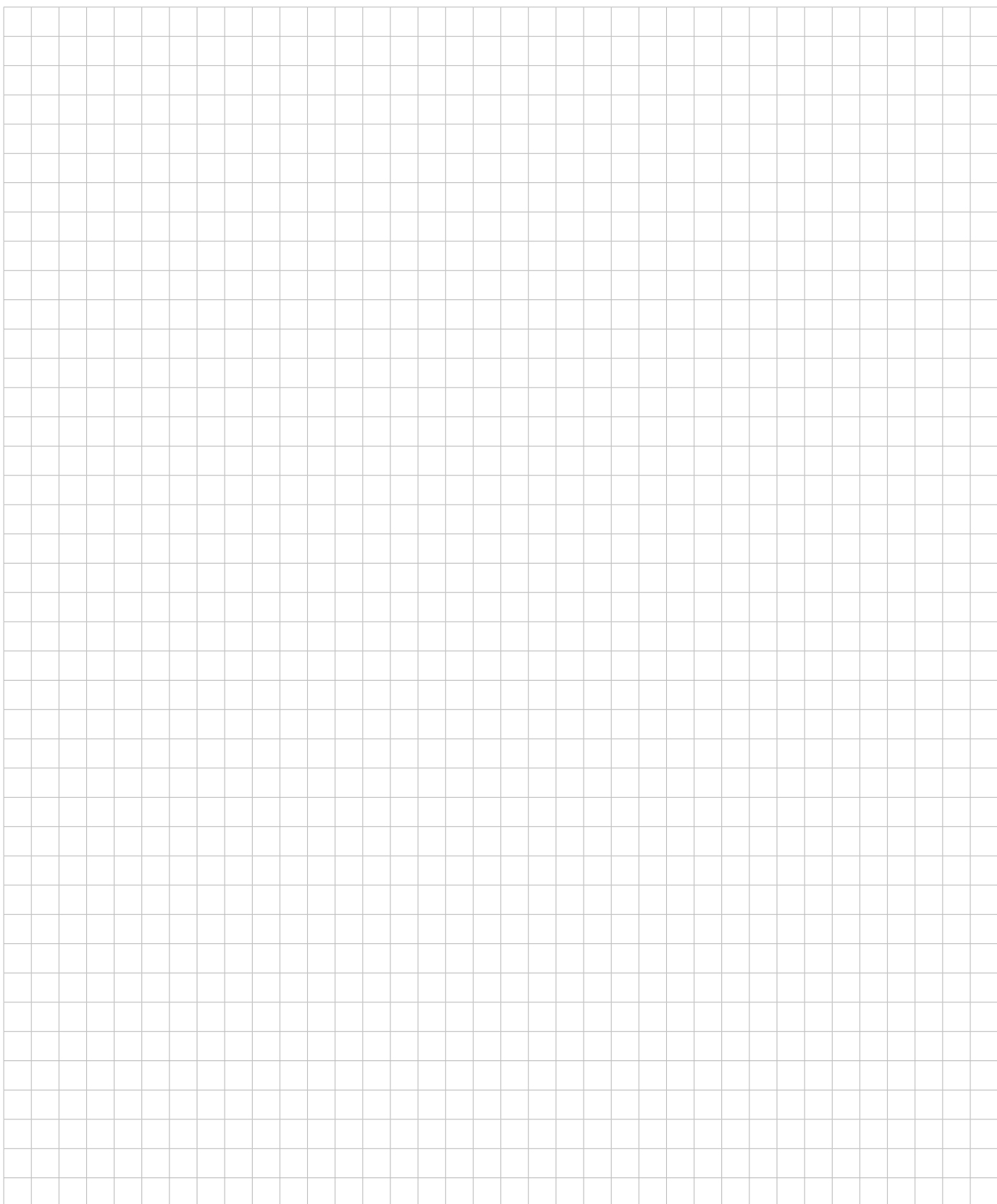

heimatec.u-tec®

heimatec.com

Products / Tool change systems /
u-tec® Tool-changing system



versions see catalog



heimatec.easy-quick

heimatec.com

Products / Tool change systems /
easy-quick HT quick-changing system



versions see catalog



heimatec.Capto™

heimatec.com

Products / Tool change systems /
heimatec.Capto™ quick-changing system



versions see catalog

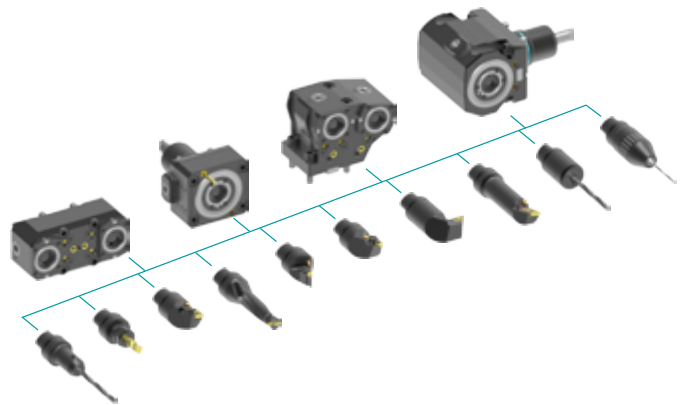

heimatec.accessories

heimatec.com

Products / Accessories



versions see catalog





● heimatec overseas branches

○ global representations of heimatec

heimatec[®]

heimatec GmbH
Präzisionswerkzeuge
Carl-Benz-Str. 4
77871 Renchen
Germany

T +49 7843 9466 0
www.heimatec.com
info@heimatec.com

Please find the contact details of our worldwide trading partners on our website:
<https://heimatec.com/business-partners>