

SPINNER
TTC 300-S



High-tech from heimatec - heimatec - Tools and systems for productive turning and milling

heimatec belongs to the international technology and quality leaders for precision tools and specializes in the development and production of high-precision static and live tools for all CNC lathes, CNC turn-/mill machines and CNC machining centers.

The range of products* spans from static BMT and VDI tool holders, live tools up to highly complex customer-specific individual solutions. heimatec, headquartered in Renchen, has a own subsidiary in Asia and India and numerous representatives as well as trading partners all over the world.

*OUR PRODCUTS

Static tool holders

Live tool units

Precision tools

Tools for turning and machining centres

Tools for swiss type lathes

Tool changing and uick-change systems

Tool systems for gear production

Digital tool management

This catalogue, including all its parts, is protected by copyright. Any use outside the restricted limitations of the Copyright Act without the consent of heimatec is inadmissible and liable to prosecution. This applies in particular to duplication, translation, microfilming and storage and processing in electronic systems.

heimatec GmbH reserves the right to make technical changes at any time without giving prior notice. This applies in particular to adjustments at any time to meet new or changed international standards, or in case of further developments of our products or manufacturing processes.

The current version of our General Terms and Conditions can be found on our website.

SPINNER



TTC 300-S

Part-#	Name	
8 200 20 001	Plug Z2-25 K	
	Weight [kg]:	0.020
	Shank size [mm]:	25.00
	Shank type:	VDI
8 200 20 004	Plug Z2-25 S	
	Weight [kg]:	0.480
	Shank size [mm]:	25.00
	Shank type:	VDI
8 200 22 000	Tool holder A1-25x 75	
	Shank size [mm]:	25.00
	Shank type:	VDI
8 202 20 011	Basic holder longitudinal seat FN 12	
	Weight [kg]:	0.800
	Version:	universal
	Shank size [mm]:	25.00
	Shank type:	VDI
	Tool adaption:	Interface FN 12
	Coolant:	EXT
8 209 21 005	Adapter for VDI 20	
	Version:	left
	Shank size [mm]:	25.00
	Shank type:	VDI
	Tool adaption:	DIN 69880 - 20
	Center distance [mm]:	75
8 209 22 012	Adapter for VDI 25	
	Version:	right
	Shank size [mm]:	25.00
	Shank type:	VDI
	Tool adaption:	DIN 69880 - 25
	Center distance [mm]:	75
8 209 22 013	Adapter for VDI 25	
	Weight [kg]:	2.430
	Version:	left
	Shank size [mm]:	25.00
	Shank type:	VDI
	Tool adaption:	DIN 69880 - 25
	Coolant:	EXT
	Center distance [mm]:	75
8 209 22 014	Adapter for VDI 25	
	Notation:	offset
	Version:	right
	Shank size [mm]:	25.00
	Shank type:	VDI
	Tool adaption:	DIN 69880 - 25
	Center distance [mm]:	75

SPINNER

TTC 300-S

Part-#	Name	
8 209 22 015	Adapter for VDI 25	
	Weight [kg]:	2.920
	Notation:	offset
	Version:	left
	Shank size [mm]:	25.00
	Shank type:	VDI
	Tool adaption:	DIN 69880 - 25
	Center distance [mm]:	75
8 214 21 001	Tool holder C3-25x16	
	Weight [kg]:	1.070
	Shank size [mm]:	25.00
	Shank type:	VDI
	Tool adaption:	Sq. 16/12
	Coolant:	EXT
8 214 21 003	Tool holder C1-25x16/12	
	Shank size [mm]:	25.00
	Shank type:	VDI
	Tool adaption:	Sq. 16/12
	Coolant:	EXT
8 214 24 001	Universal turning holder sq. 20	
	Weight [kg]:	1.460
	Shank size [mm]:	25.00
	Shank type:	VDI
	Tool adaption:	Sq. 20 Sq. 20
	Coolant:	EXT
	Please note:	with reversible shaft
8 215 21 001	Tool holder C2-25x16	
	Weight [kg]:	1.100
	Version:	Left
	Shank size [mm]:	25.00
	Shank type:	VDI
	Tool adaption:	Sq. 16/12
	Coolant:	EXT
8 215 21 002	Tool holder C4-25x16	
	Version:	Left
	Shank size [mm]:	25.00
	Shank type:	VDI
	Tool adaption:	Sq. 16/12
	Coolant:	EXT
8 215 22 002	Tool holder C4-25x20/16	
	Version:	left
	Shank size [mm]:	25.00
	Shank type:	VDI
	Tool adaption:	Sq. 20/16
	Coolant:	EXT

Part-#	Name	
8 215 22 003	Tool holder C2-25x20/16	
	Weight [kg]:	1.140
	Version:	left
	Shank size [mm]:	25.00
	Shank type:	VDI
	Tool adaption:	Sq. 20/16
	Coolant:	EXT
8 216 22 000	Tool holder C1/C4-25x20/16	
	Weight [kg]:	1.150
	Employment for:	VDI 25
	Version:	doubletoothed
	Shank size [mm]:	25.00
	Shank type:	VDI
	Tool adaption:	Sq. 20/16
	Coolant:	EXT
8 230 27 024	Boring bar holder Ø 25	
	Weight [kg]:	2.860
	Version:	right
	Shank size [mm]:	25.00
	Shank type:	VDI
	Tool adaption:	Ø 25
	Coolant:	IC/Ext
	Please note:	demountable in left version
	Center distance [mm]:	75
8 230 27 041	Boring bar holder Ø 30	
	Weight [kg]:	2.770
	Version:	right
	Shank size [mm]:	25.00
	Shank type:	VDI
	Tool adaption:	Ø 30
	Coolant:	IC/Ext
	Please note:	demountable in left version
	Center distance [mm]:	75
8 230 27 049	Boring bar holder Ø 25	
	Weight [kg]:	3.420
	Version:	right
	Shank size [mm]:	25.00
	Shank type:	VDI
	Tool adaption:	Ø 25
	Coolant:	IC/Ext
	Please note:	demountable in left version
	Center distance [mm]:	95
8 230 27 054	Boring bar holder Ø 1"	
	Weight [kg]:	2.850
	Version:	right
	Shank size [mm]:	25.00
	Shank type:	VDI
	Tool adaption:	Ø 1" (25,4mm)
	Coolant:	IC/Ext
	Please note:	demountable in left version
	Center distance [mm]:	75

SPINNER

TTC 300-S

Part-#	Name	
8 230 28 019	Boring bar holder Ø 32	
	Notation:	offset
	Version:	right
	Shank size [mm]:	25.00
	Shank type:	VDI
	Tool adaption:	Ø 32
	Coolant:	IC/Ext
	Center distance [mm]:	75
8 231 24 001	Collet chuck holder ER 20	
	Weight [kg]:	2.800
	Notation:	offset
	Version:	left
	Shank size [mm]:	25.00
	Shank type:	VDI
	Tool adaption:	ER 20
	Coolant:	IC/Ext
	Center distance [mm]:	75
8 231 25 004	Collet chuck holder ER 25	
	Weight [kg]:	3.140
	Notation:	offset
	Version:	left
	Shank size [mm]:	25.00
	Shank type:	VDI
	Tool adaption:	ER 25
	Coolant:	IC/Ext
	Center distance [mm]:	75
8 231 26 007	Tool holder HT 4	
	Notation:	offset
	Version:	left
	Shank size [mm]:	25.00
	Shank type:	VDI
	Tool adaption:	HT 4
	Coolant:	IC/Ext
	Please note:	HT- insert demountable
	Center distance [mm]:	75
8 231 28 001	Boring bar holder Ø 32	
	Version:	left
	Shank size [mm]:	25.00
	Shank type:	VDI
	Tool adaption:	Ø 32
	Coolant:	IC/Ext
	Please note:	demountable in right version
	Center distance [mm]:	75
8 231 28 003	Boring bar holder Ø 32	
	Notation:	offset
	Version:	left
	Shank size [mm]:	25.00
	Shank type:	VDI
	Tool adaption:	Ø 32
	Coolant:	IC/Ext
	Center distance [mm]:	75

SPINNER

TTC 300-S

Part-#	Name	
8 231 28 033	Boring bar holder Ø 32	
	Version:	left
	Shank size [mm]:	25.00
	Shank type:	VDI
	Tool adaption:	Ø 32
	Coolant:	IC/Ext
	Please note:	demountable in right version
	Center distance [mm]:	95
8 234 24 004	Combi facing holder sq. 20	
	Weight [kg]:	2.320
	Shank size [mm]:	25.00
	Shank type:	VDI
	Tool adaption:	Sq. 20
	Coolant:	EXT
	Please note:	demountable in left version
8 236 26 006	Tool holder HT 4	
	Notation:	180° reversible
	Version:	doubletoothed
	Shank size [mm]:	25.00
	Shank type:	VDI
	Tool adaption:	HT 4
	Coolant:	IC/Ext
	Please note:	Fixation slide stone
	Center distance [mm]:	75
8 236 27 014	Boring bar holder Ø 25	
	Version:	doubletoothed
	Shank size [mm]:	25.00
	Shank type:	VDI
	Tool adaption:	Ø 25
	Coolant:	IC/Ext
	Pressure max [bar]:	100
	Center distance [mm]:	95
8 239 26 029	Double tool holder HT 4	
	Weight [kg]:	2.840
	Employment for:	Main- and sub spindle
	Shank size [mm]:	25.00
	Shank type:	VDI
	Tool adaption:	HT 4
	Coolant:	IC/Ext
	Center distance [mm]:	75
8 251 23 003	Combi double turning holder sq.20/16	
	Weight [kg]:	1.920
	Employment for:	Main- and sub spindle
	Shank size [mm]:	25.00
	Shank type:	VDI
	Tool adaption:	Sq. 20/16
	Coolant:	EXT
	Please note:	usable as C1, C2, C3, C4

SPINNER

TTC 300-S

Part-#	Name	
8 253 25 001	Double boring bar holder Ø 16	
	Weight [kg]:	4.900
	Shank size [mm]:	25.00
	Shank type:	VDI
	Tool adaption:	Ø 16
	Coolant:	IC/Ext
	Center distance [mm]:	70/105
8 253 26 010	Multiple tool holder HT 4	
	Weight [kg]:	4.580
	Version:	Special; double spindle
	Shank size [mm]:	25.00
	Shank type:	VDI
	Tool adaption:	HT 4
		HT 4
		HT 4
		HT 4
	Coolant:	IC/Ext
	Please note:	Check applicability; tool height 132,5 mm
	Center distance [mm]:	70/112
8 253 26 011	Double tool holder HT 4	
	Weight [kg]:	4.550
	Version:	Special
	Shank size [mm]:	25.00
	Shank type:	VDI
	Tool adaption:	HT 4
		HT 4
	Coolant:	IC/Ext
	Please note:	Check applicability; tool height 132,5 mm
	Center distance [mm]:	70/112
8 253 27 008	Double boring bar holder Ø 25	
	Weight [kg]:	4.430
	Shank size [mm]:	25.00
	Shank type:	VDI
	Tool adaption:	Ø 25
	Coolant:	IC/Ext
	Center distance [mm]:	70/105
8 262 29 015	Stock stop VDI 25 - Ø 60 OD turret	
	Weight [kg]:	2.730
	Notation:	offset
	Version:	right
	Shank size [mm]:	25.00
	Shank type:	VDI
	Rotation max [1/min]:	8000
	Coolant:	no
	Please note:	Lenght adjustable
	Center distance [mm]:	75
8 274 21 001	Tool holder D1-25x16	
	Weight [kg]:	1.020
	Shank size [mm]:	25.00
	Shank type:	VDI
	Tool adaption:	Sq. 16/12
	Coolant:	EXT

SPINNER TTC 300-S

Part-#	Name	
8 274 21 002	Tool holder D2-25x16	
	Weight [kg]:	1.220
	Shank size [mm]:	25.00
	Shank type:	VDI
	Tool adaption:	Sq. 16/12
	Coolant:	EXT
8 320 23 014	Cut-off holder, height adjustable SH 32 IC	
	Weight [kg]:	1.370
	Version:	universal
	Shank size [mm]:	25.00
	Shank type:	VDI
	Tool adaption:	Clampshaft SH 32
	Coolant:	IC/Ext
	Pressure max [bar]:	70
8 320 23 020	Cut-off holder, height adjustable SH 32 IC	
	Weight [kg]:	1.540
	Version:	universal
	Shank size [mm]:	25.00
	Shank type:	VDI
	Tool adaption:	Clampshaft SH 32
	Coolant:	IC/Ext
	Pressure max [bar]:	70
	Please note:	Clampshaft internal



heimatec.u-tec®

heimatec.com

Products / Tool change systems /
u-tec® Tool-changing system



versions see catalog

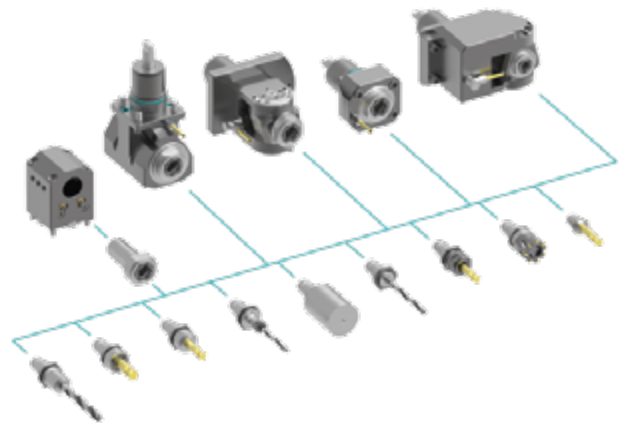

heimatec.easy-quick

heimatec.com

Products / Tool change systems /
easy-quick HT quick-changing system



versions see catalog

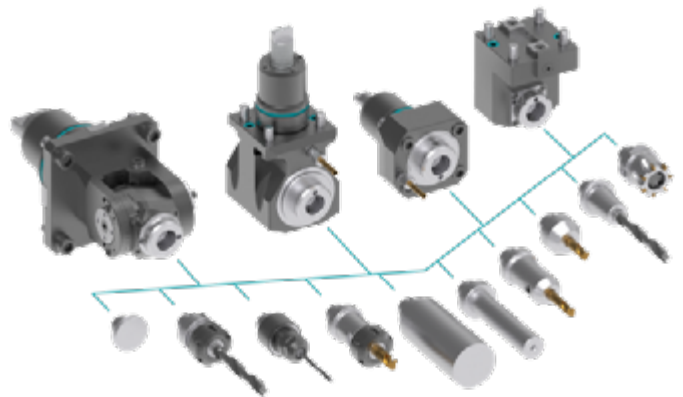

heimatec.Capto™

heimatec.com

Products / Tool change systems /
heimatec.Capto™ quick-changing system



versions see catalog

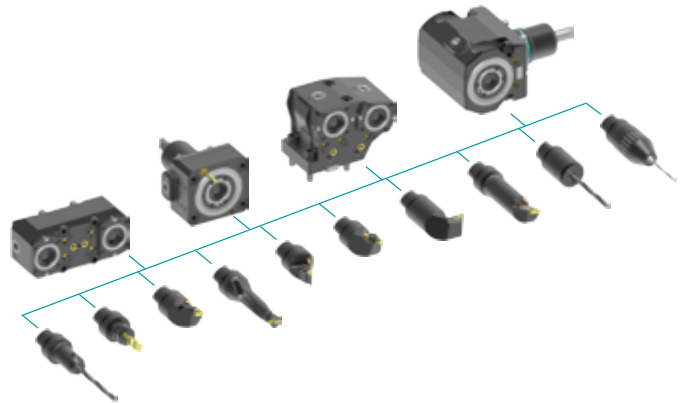

heimatec.accessories

heimatec.com

Products / Accessories



versions see catalog





● heimatec overseas branches

○ global representations of heimatec

heimatec[®]

heimatec GmbH
Präzisionswerkzeuge
Carl-Benz-Str. 4
77871 Renchen
Germany

T +49 7843 9466 0
www.heimatec.com
info@heimatec.com

Please find the contact details of our worldwide trading partners on our website:
<https://heimatec.com/business-partners>