

Nakamura  
**Super**  
**NTJ-unterer**



# High-tech from heimatec - heimatec - Tools and systems for productive turning and milling

heimatec belongs to the international technology and quality leaders for precision tools and specializes in the development and production of high-precision static and live tools for all CNC lathes, CNC turn-/mill machines and CNC machining centers.

The range of products\* spans from static BMT and VDI tool holders, live tools up to highly complex customer-specific individual solutions. heimatec, headquartered in Renchen, has a own subsidiary in Asia and India and numerous representatives as well as trading partners all over the world.

## \*OUR PRODCUTS

Static tool holders

Live tool units

Precision tools

Tools for turning and machining centres

Tools for swiss type lathes

Tool changing and uick-change systems



Tool systems for gear production





Digital tool management

This catalogue, including all its parts, is protected by copyright. Any use outside the restricted limitations of the Copyright Act without the consent of heimatec is inadmissible and liable to prosecution. This applies in particular to duplication, translation, microfilming and storage and processing in electronic systems.

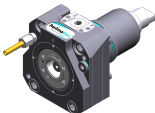
**heimatec GmbH** reserves the right to make technical changes at any time without giving prior notice. This applies in particular to adjustments at any time to meet new or changed international standards, or in case of further developments of our products or manufacturing processes.





The current version of our General Terms and Conditions can be found on our website.

| Part-#  | Name   |   |
|---|--|---|
| <b>8 010 55 033</b>   | <b>Axial milling and drill holder ER 25 AX UT</b>    |   |
|    | Weight [kg]:   | 2.830   |
|   | Tool drive:  | Flat (~DIN 1809)                                      |
|   | Shank size [mm]:                                     | 55.00   |
|   | Shank type:  | BMT   |
|   | Tool adaption:                                       | ER 25 A - u-tec                                       |
|   | Gear ratio [i]:                                      | 1:1   |
|   | Torque max [Nm]:                                     | 50  |
|   | Rotation max [1/min]:                                | 6000  |
|   | Rotating direction:                                  | same  |
|   | Coolant:   | EXT   |
|   | Please note:   | Combi bearing   |
| <b>8 010 55 035</b>   | <b>Axial milling and drill holder ER 25 AX UT IC</b> |   |
|    | Weight [kg]:   | 2.860   |
|   | Tool drive:  | Flat (~DIN 1809)                                      |
|   | Shank size [mm]:                                     | 55.00   |
|   | Shank type:  | BMT   |
|   | Tool adaption:                                       | ER 25 A - u-tec                                       |
|   | Gear ratio [i]:                                      | 1:1   |
|   | Torque max [Nm]:                                     | 50  |
|   | Rotation max [1/min]:                                | 6000  |
|   | Rotating direction:                                  | same  |
|   | Coolant:   | IC/Ext  |
|   | Pressure max [bar]:                                  | 100   |
|   | Please note:   | Combi bearing; high pressure version; dryrun possible |
| <b>8 010 55 049</b>   | <b>Axial drilling and milling head Weldon 16</b>     |   |
|  | Weight [kg]:   | 3.140   |
|   | Tool drive:  | Flat (~DIN 1809)                                      |
|   | Shank size [mm]:                                     | 55.00   |
|   | Shank type:  | BMT   |
|   | Tool adaption:                                       | Weldon (DIN 1835 b) 16                                |
|   | Gear ratio [i]:                                      | 1:1   |
|   | Torque max [Nm]:                                     | 50  |
|   | Rotation max [1/min]:                                | 6000  |
|   | Rotating direction:                                  | same  |
|   | Coolant:   | EXT   |
|   | Please note:   | Combi bearing   |
| <b>8 010 55 068</b>   | <b>Axial drilling and milling head C 3</b>           |   |
|  | Notation:  | 180° reversible                                       |
|   | Tool drive:  | Flat (~DIN 1809)                                      |
|   | Shank type:  | BMT   |
|   | Tool adaption:                                       | heimatec Capto(TM) C 3                                |
|   | Gear ratio [i]:                                      | 1:1   |
|   | Torque max [Nm]:                                     | 32  |
|   | Rotation max [1/min]:                                | 8000  |
|   | Rotating direction:                                  | same  |
|   | Coolant:   | EXT   |

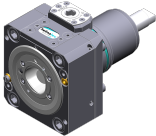

| Part-#  | Name  |                                    |
|---|---|------------------------------------|
| <b>8 010 55 069</b>   | <b>Axial drilling and milling head C 3 IC</b>         |                                    |
|    | Notation:   | 180° reversible                    |
|   | Tool drive:   | Flat (~DIN 1809)                   |
|   | Shank type:   | BMT                                |
|   | Tool adaption:  | heimatec Capto(TM) C 3             |
|   | Gear ratio [i]:                                       | 1:1                                |
|   | Torque max [Nm]:                                      | 32                                 |
|   | Rotation max [1/min]:                                 | 8000                               |
|   | Rotating direction:                                   | same                               |
|   | Coolant:  | IC/Ext                             |
|   | Pressure max [bar]:                                   | 100                                |
| <b>8 010 55 078</b>   | <b>Axial drilling and milling head Weldon 3/4" IC</b> |                                    |
|    | Weight [kg]:  | 3.200                              |
|   | Tool drive:   | Flat (~DIN 1809)                   |
|   | Shank size [mm]:                                      | 55.00                              |
|   | Shank type:   | BMT                                |
|   | Tool adaption:  | Weldon (DIN 1835 b) 3/4" (19,05mm) |
|   | Gear ratio [i]:                                       | 1:1                                |
|   | Torque max [Nm]:                                      | 50                                 |
|   | Rotation max [1/min]:                                 | 6000                               |
|   | Rotating direction:                                   | same                               |
|   | Coolant:  | IC/Ext                             |
|   | Pressure max [bar]:                                   | 25                                 |
|   | Please note:  | Combi bearing                      |
| <b>8 010 55 081</b>   | <b>Axial drilling and milling head Weldon 3/4"</b>    |                                    |
|  | Weight [kg]:  | 3.200                              |
|   | Tool drive:   | Flat (~DIN 1809)                   |
|   | Shank size [mm]:                                      | 55.00                              |
|   | Shank type:   | BMT                                |
|   | Tool adaption:  | Weldon (DIN 1835 b) 3/4" (19,05mm) |
|   | Gear ratio [i]:                                       | 1:1                                |
|   | Torque max [Nm]:                                      | 50                                 |
|   | Rotation max [1/min]:                                 | 6000                               |
|   | Rotating direction:                                   | same                               |
|   | Coolant:  | EXT                                |
|   | Please note:  | Combi bearing                      |
| <b>8 010 55 092</b>   | <b>Axial drilling and milling head ER 25 AX UT IC</b> |                                    |
|  | Weight [kg]:  | 2.870                              |
|   | Tool drive:   | Flat (~DIN 1809)                   |
|   | Shank size [mm]:                                      | 55.00                              |
|   | Shank type:   | BMT                                |
|   | Tool adaption:  | ER 25 A - u-tec                    |
|   | Gear ratio [i]:                                       | 1:1                                |
|   | Torque max [Nm]:                                      | 50                                 |
|   | Rotation max [1/min]:                                 | 6000                               |
|   | Rotating direction:                                   | same                               |
|   | Coolant:  | IC air                             |
|   | Pressure max [bar]:                                   | 10                                 |
|   | Please note:  | Combi bearing                      |

| Part-#  | Name  |                  |
|---|---|------------------|
| <b>8 010 55 109</b>   | <b>Axial drilling and milling head ER 25 AX UT</b>    |                  |
|    | Weight [kg]:  | 2.600            |
|   | Tool drive:   | Flat (~DIN 1809) |
|   | Shank size [mm]:                                      | 55.00            |
|   | Shank type:   | BMT              |
|   | Tool adaption:  | ER 25 A - u-tec  |
|   | Gear ratio [i]:                                       | 1:1              |
|   | Torque max [Nm]:                                      | 50               |
|   | Rotation max [1/min]:                                 | 12000            |
|   | Rotating direction:                                   | same             |
|   | Coolant:  | EXT              |
| <b>8 010 55 111</b>   | <b>Axial drilling and milling head ER 25 AX UT IC</b> |                  |
|    | Weight [kg]:  | 3.000            |
|   | Tool drive:   | Flat (~DIN 1809) |
|   | Shank size [mm]:                                      | 55.00            |
|   | Shank type:   | BMT              |
|   | Tool adaption:  | ER 25 A - u-tec  |
|   | Gear ratio [i]:                                       | 1:1              |
|   | Torque max [Nm]:                                      | 50               |
|   | Rotation max [1/min]:                                 | 15000            |
|   | Rotating direction:                                   | same             |
|   | Coolant:  | IC/Ext           |
|   | Pressure max [bar]:                                   | 100              |
|   | Please note:  | Dryrun possible  |
| <b>8 010 56 031</b>   | <b>Axial drilling and milling head HT 4 IC</b>        |                  |
|  | Weight [kg]:  | 1.760            |
|   | Tool drive:   | Flat (~DIN 1809) |
|   | Shank size [mm]:                                      | 55.00            |
|   | Shank type:   | BMT              |
|   | Tool adaption:  | HT 4             |
|   | Gear ratio [i]:                                       | 1:1              |
|   | Torque max [Nm]:                                      | 50               |
|   | Rotation max [1/min]:                                 | 6000             |
|   | Rotating direction:                                   | same             |
|   | Coolant:  | IC/Ext           |
|   | Pressure max [bar]:                                   | 25               |
|   | Please note:  | short version    |
| <b>8 010 56 032</b>   | <b>Axial drilling and milling head HT 4</b>           |                  |
|  | Weight [kg]:  | 1.740            |
|   | Tool drive:   | Flat (~DIN 1809) |
|   | Shank size [mm]:                                      | 55.00            |
|   | Shank type:   | BMT              |
|   | Tool adaption:  | HT 4             |
|   | Gear ratio [i]:                                       | 1:1              |
|   | Torque max [Nm]:                                      | 50               |
|   | Rotation max [1/min]:                                 | 6000             |
|   | Rotating direction:                                   | same             |
|   | Coolant:  | EXT              |
|   | Please note:  | short version    |

| Part-#  | Name   |                                |
|---|--|--------------------------------|
| <b>8 010 56 059</b>   | <b>Axial drilling and milling head HT 4</b>          |                                |
|    | Weight [kg]:   | 2.880                          |
|   | Tool drive:  | Flat (~DIN 1809)               |
|   | Shank size [mm]:                                     | 55.00                          |
|   | Shank type:  | BMT                            |
|   | Tool adaption:                                       | HT 4                           |
|   | Gear ratio [i]:                                      | 1:1                            |
|   | Torque max [Nm]:                                     | 50                             |
|   | Rotation max [1/min]:                                | 6000                           |
|   | Rotating direction:                                  | same                           |
|   | Coolant:   | EXT                            |
|   | Please note:   | Combi bearing                  |
| <b>8 010 56 063</b>   | <b>Axial milling and drill holder ER 32 AX UT</b>    |                                |
|    | Weight [kg]:   | 3.000                          |
|   | Tool drive:  | Flat (~DIN 1809)               |
|   | Shank size [mm]:                                     | 55.00                          |
|   | Shank type:  | BMT                            |
|   | Tool adaption:                                       | ER 32 A - u-tec                |
|   | Gear ratio [i]:                                      | 1:1                            |
|   | Torque max [Nm]:                                     | 50                             |
|   | Rotation max [1/min]:                                | 6000                           |
|   | Rotating direction:                                  | same                           |
|   | Coolant:   | EXT                            |
|   | Please note:   | Combi bearing                  |
| <b>8 010 56 064</b>   | <b>Axial milling and drill holder ER 32 AX UT IC</b> |                                |
|  | Weight [kg]:   | 3.020                          |
|   | Tool drive:  | Flat (~DIN 1809)               |
|   | Shank size [mm]:                                     | 55.00                          |
|   | Tool adaption:                                       | ER 32 A - u-tec                |
|   | Gear ratio [i]:                                      | 1:1                            |
|   | Torque max [Nm]:                                     | 50                             |
|   | Rotation max [1/min]:                                | 6000                           |
|   | Rotating direction:                                  | same                           |
|   | Coolant:   | IC/Ext                         |
|   | Pressure max [bar]:                                  | 25                             |
|   | Please note:   | Combi bearing                  |
| <b>8 010 56 065</b>   | <b>Axial milling and drill holder ER 32 AX UT IC</b> |                                |
|  | Weight [kg]:   | 3.020                          |
|   | Tool drive:  | Flat (~DIN 1809)               |
|   | Shank size [mm]:                                     | 55.00                          |
|   | Shank type:  | BMT                            |
|   | Tool adaption:                                       | ER 32 A - u-tec                |
|   | Gear ratio [i]:                                      | 1:1                            |
|   | Torque max [Nm]:                                     | 50                             |
|   | Rotation max [1/min]:                                | 6000                           |
|   | Rotating direction:                                  | same                           |
|   | Coolant:   | IC/Ext                         |
|   | Pressure max [bar]:                                  | 100                            |
|   | Please note:   | Combi bearing; dryrun possible |

| Part-#   | Name   |                        |
|--|--|------------------------|
| <b>8 010 56 066</b><br>   | <b>Axial drilling and milling head HT 4 IC</b>   |                        |
|  | Weight [kg]:                                     | 2.930                  |
|  | Tool drive:                                      | Flat (~DIN 1809)       |
|  | Shank size [mm]:                                 | 55.00                  |
|  | Shank type:                                      | BMT                    |
|  | Tool adaption:                                   | HT 4                   |
|  | Gear ratio [i]:                                  | 1:1                    |
|  | Torque max [Nm]:                                 | 50                     |
|  | Rotation max [1/min]:                            | 6000                   |
|  | Rotating direction:                              | same                   |
|  | Coolant:   | IC/Ext                 |
| Pressure max [bar]:  | 25   |                        |
| Please note:   | Combi bearing                                    |                        |
| <b>8 010 56 069</b><br>   | <b>Axial drilling and milling head Weldon 20</b> |                        |
|  | Weight [kg]:                                     | 3.200                  |
|  | Tool drive:                                      | Flat (~DIN 1809)       |
|  | Shank size [mm]:                                 | 55.00                  |
|  | Shank type:                                      | BMT                    |
|  | Tool adaption:                                   | Weldon (DIN 1835 b) 20 |
|  | Gear ratio [i]:                                  | 1:1                    |
|  | Torque max [Nm]:                                 | 50                     |
|  | Rotation max [1/min]:                            | 6000                   |
|  | Rotating direction:                              | same                   |
|  | Coolant:   | EXT                    |
| Please note:   | Combi bearing                                    |                        |
| <b>8 010 56 110</b><br> | <b>Axial drilling and milling head C 4</b>       |                        |
|  | Weight [kg]:                                     | 4.750                  |
|  | Notation:  | 180° reversible        |
|  | Tool drive:                                      | Flat (~DIN 1809)       |
|  | Shank size [mm]:                                 | 55.00                  |
|  | Shank type:                                      | BMT                    |
|  | Tool adaption:                                   | heimatec Capto(TM) C 4 |
|  | Gear ratio [i]:                                  | 1:1                    |
|  | Torque max [Nm]:                                 | 50                     |
|  | Rotation max [1/min]:                            | 6000                   |
|  | Rotating direction:                              | same                   |
| Coolant:   | EXT  |                        |
| Please note:   | Check applicability; tool length check !         |                        |
| <b>8 010 56 111</b><br> | <b>Axial drilling and milling head C 4 IC</b>    |                        |
|  | Weight [kg]:                                     | 5.800                  |
|  | Notation:  | 180° reversible        |
|  | Tool drive:                                      | Flat (~DIN 1809)       |
|  | Shank size [mm]:                                 | 55.00                  |
|  | Shank type:                                      | BMT                    |
|  | Machine adaption:                                | Centering key b 20     |
|  | Tool adaption:                                   | heimatec Capto(TM) C 4 |
|  | Gear ratio [i]:                                  | 1:1                    |
|  | Torque max [Nm]:                                 | 50                     |
|  | Rotation max [1/min]:                            | 6000                   |
| Rotating direction:  | same   |                        |
| Coolant:   | IC/Ext   |                        |
| Pressure max [bar]:  | 100  |                        |
| Please note:   | Check applicability; tool length check !         |                        |

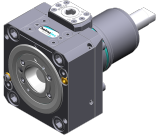

Nakamura  
Super NTJ-unterer Revolver

| Part-#  | Name  |  |
|---|---|--|
| <b>8 010 56 120</b>   | <b>Axial drilling and milling head C 4 IC</b>   |  |
|    | Notation: 180° reversible<br>Tool drive: Flat (~DIN 1809)<br>Shank size [mm]: 55.00<br>Shank type: BMT<br>Machine adaption: Centering key b 20<br>Tool adaption: heimatec Capto(TM) C 4<br>Gear ratio [i]: 1:1<br>Torque max [Nm]: 50<br>Rotation max [1/min]: 6000<br>Rotating direction: same<br>Coolant: IC/Ext<br>Pressure max [bar]: 25<br>Please note: Check applicability; tool length check ! |  |
| <b>8 010 56 138</b>   | <b>Axial drilling and milling head C 4</b>  |  |
|    | Weight [kg]: 4.730<br>Notation: 180° reversible<br>Tool drive: Flat (~DIN 1809)<br>Shank size [mm]: 55.00<br>Shank type: BMT<br>Tool adaption: heimatec Capto(TM) C 4<br>Gear ratio [i]: 1:1<br>Torque max [Nm]: 50<br>Rotation max [1/min]: 12000<br>Rotating direction: same<br>Coolant: EXT<br>Please note: Check applicability; tool length check !   |  |
| <b>8 010 56 140</b>   | <b>Axial drilling and milling head ER 32 AX UT IC</b>   |  |
|  | Weight [kg]: 3.000<br>Tool drive: Flat (~DIN 1809)<br>Shank size [mm]: 55.00<br>Shank type: BMT<br>Tool adaption: ER 32 A - u-tec<br>Gear ratio [i]: 1:1<br>Torque max [Nm]: 50<br>Rotation max [1/min]: 6000<br>Rotating direction: same<br>Coolant: IC/Ext<br>Pressure max [bar]: 100   |  |
| <b>8 010 56 144</b>   | <b>Axial drilling and milling head HT 4 IC</b>  |  |
|  | Tool drive: Flat (~DIN 1809)<br>Shank size [mm]: 55.00<br>Shank type: BMT<br>Tool adaption: HT 4<br>Gear ratio [i]: 1:1<br>Torque max [Nm]: 50<br>Rotation max [1/min]: 6000<br>Rotating direction: same<br>Coolant: IC/Ext<br>Pressure max [bar]: 100  |  |

Nakamura  
Super NTJ-unterer Revolver

| Part-#  | Name  |                        |
|---|---|------------------------|
| <b>8 010 56 151</b>   | <b>Axial drilling and milling head ER 32 AX UT</b>    |                        |
|  | Weight [kg]:  | 2.770                  |
|   | Tool drive:   | Flat (~DIN 1809)       |
|   | Shank size [mm]:                                      | 55.00                  |
|   | Shank type:   | BMT                    |
|   | Tool adaption:  | ER 32 A - u-tec        |
|   | Gear ratio [i]:                                       | 1:1                    |
|   | Torque max [Nm]:                                      | 50                     |
|   | Rotation max [1/min]:                                 | 12000                  |
|   | Rotating direction:                                   | same                   |
|   | Coolant:  | EXT                    |
| <b>8 010 56 153</b>   | <b>Axial drilling and milling head ER 32 AX UT IC</b> |                        |
|  | Weight [kg]:  | 3.180                  |
|   | Tool drive:   | Flat (~DIN 1809)       |
|   | Shank size [mm]:                                      | 55.00                  |
|   | Shank type:   | BMT                    |
|   | Tool adaption:  | ER 32 A - u-tec        |
|   | Gear ratio [i]:                                       | 1:1                    |
|   | Torque max [Nm]:                                      | 50                     |
|   | Rotation max [1/min]:                                 | 15000                  |
|   | Rotating direction:                                   | same                   |
|   | Coolant:  | IC/Ext                 |
|   | Pressure max [bar]:                                   | 100                    |
| <b>8 010 57 065</b>   | <b>Axial drilling and milling head Weldon 25 IC</b>   |                        |
|   | Weight [kg]:  | 3.250                  |
|   | Tool drive:   | Flat (~DIN 1809)       |
|   | Shank size [mm]:                                      | 55.00                  |
|   | Shank type:   | BMT                    |
|   | Tool adaption:  | Weldon (DIN 1835 b) 25 |
|   | Gear ratio [i]:                                       | 1:1                    |
|   | Torque max [Nm]:                                      | 50                     |
|   | Rotation max [1/min]:                                 | 6000                   |
|   | Rotating direction:                                   | same                   |
|   | Coolant:  | IC/Ext                 |
|   | Pressure max [bar]:                                   | 25                     |
|   | Please note:  | Combi bearing          |
| <b>8 010 57 066</b>   | <b>Axial drilling and milling head Weldon 25</b>      |                        |
|   | Weight [kg]:  | 3.230                  |
|   | Version:  | long; special          |
|   | Tool drive:   | Flat (~DIN 1809)       |
|   | Shank size [mm]:                                      | 55.00                  |
|   | Shank type:   | BMT                    |
|   | Tool adaption:  | Weldon (DIN 1835 b) 25 |
|   | Gear ratio [i]:                                       | 1:1                    |
|   | Torque max [Nm]:                                      | 50                     |
|   | Rotation max [1/min]:                                 | 6000                   |
|   | Rotating direction:                                   | same                   |
|   | Coolant:  | EXT                    |
|   | Please note:  | Combi bearing          |

Nakamura  
Super NTJ-unterer Revolver

| Part-#  | Name  |                                    |
|---|---|------------------------------------|
| <b>8 011 54 006</b>   | <b>Axial milling head universal arbor 3/4"</b>  |                                    |
|    | Weight [kg]:                                    | 2.910                              |
|   | Tool drive:                                     | Flat (~DIN 1809)                   |
|   | Shank size [mm]:                                | 55.00                              |
|   | Shank type:                                     | BMT                                |
|   | Tool adaption:                                  | Universal arbor 3/4" (19,05mm)     |
|   | Gear ratio [i]:                                 | 1:1                                |
|   | Torque max [Nm]:                                | 50                                 |
|   | Rotation max [1/min]:                           | 6000                               |
|   | Rotating direction:                             | same                               |
|   | Coolant:  | EXT                                |
|   | Please note:                                    | Combi bearing                      |
| <b>8 011 54 015</b>   | <b>Axial milling head arbor 5/8"</b>            |                                    |
|    | Weight [kg]:                                    | 2.880                              |
|   | Tool drive:                                     | Flat (~DIN 1809)                   |
|   | Shank size [mm]:                                | 55.00                              |
|   | Shank type:                                     | BMT                                |
|   | Tool adaption:                                  | Arbor 5/8" (15,875mm)              |
|   | Gear ratio [i]:                                 | 1:1                                |
|   | Torque max [Nm]:                                | 50                                 |
|   | Rotation max [1/min]:                           | 6000                               |
|   | Rotating direction:                             | same                               |
|   | Coolant:  | EXT                                |
|   | Please note:                                    | Combi bearing                      |
| <b>8 011 55 014</b>   | <b>Axial milling head universal arbor 22 IC</b> |                                    |
|  | Weight [kg]:                                    | 3.080                              |
|   | Tool drive:                                     | Flat (~DIN 1809)                   |
|   | Shank size [mm]:                                | 55.00                              |
|   | Shank type:                                     | BMT                                |
|   | Tool adaption:                                  | Universal arbor 22                 |
|   | Gear ratio [i]:                                 | 1:1                                |
|   | Torque max [Nm]:                                | 50                                 |
|   | Rotation max [1/min]:                           | 6000                               |
|   | Rotating direction:                             | same                               |
|   | Coolant:  | IC/Ext                             |
|   | Pressure max [bar]:                             | 100                                |
|   | Please note:                                    | Combi bearing, Trockenauf possible |
| <b>8 011 55 015</b>   | <b>Axial milling head universal arbor 22</b>    |                                    |
|  | Weight [kg]:                                    | 3.000                              |
|   | Tool drive:                                     | Flat (~DIN 1809)                   |
|   | Shank size [mm]:                                | 55.00                              |
|   | Shank type:                                     | BMT                                |
|   | Tool adaption:                                  | Universal arbor 22                 |
|   | Gear ratio [i]:                                 | 1:1                                |
|   | Torque max [Nm]:                                | 50                                 |
|   | Rotation max [1/min]:                           | 6000                               |
|   | Rotating direction:                             | same                               |
|   | Coolant:  | EXT                                |
|   | Please note:                                    | Combi bearing                      |

| Part-#  | Name  |                      |
|---|---|----------------------|
| <b>8 013 53 000</b>   | <b>Axial drilling and milling head ER 11</b>          |                      |
|    | Weight [kg]:  | 2.300                |
|   | Tool drive:   | Flat (~DIN 1809)     |
|   | Shank size [mm]:                                      | 55.00                |
|   | Shank type:   | BMT                  |
|   | Tool adaption:  | ER 11                |
|   | Gear ratio [i]:                                       | 1:4                  |
|   | Torque max [Nm]:                                      | 2,5                  |
|   | Rotation max [1/min]:                                 | 48000                |
|   | Rotating direction:                                   | same                 |
|   | Coolant:  | EXT                  |
| <b>8 013 54 005</b>   | <b>Axial drilling and milling head ER 16 AX UT</b>    |                      |
|    | Weight [kg]:  | 2.200                |
|   | Tool drive:   | Flat (~DIN 1809)     |
|   | Shank size [mm]:                                      | 55.00                |
|   | Shank type:   | BMT                  |
|   | Tool adaption:  | ER 16 A - u-tec      |
|   | Gear ratio [i]:                                       | 1:4                  |
|   | Torque max [Nm]:                                      | 5                    |
|   | Rotation max [1/min]:                                 | 24000                |
|   | Rotating direction:                                   | same                 |
|   | Coolant:  | EXT                  |
| <b>8 013 54 007</b>   | <b>Axial drilling and milling head ER 16 AX UT IC</b> |                      |
|  | Tool drive:   | Flat (~DIN 1809)     |
|   | Shank size [mm]:                                      | 55.00                |
|   | Shank type:   | BMT                  |
|   | Tool adaption:  | ER 16 A - u-tec      |
|   | Gear ratio [i]:                                       | 1:4                  |
|   | Torque max [Nm]:                                      | 5                    |
|   | Rotation max [1/min]:                                 | 24000                |
|   | Rotating direction:                                   | same                 |
|   | Coolant:  | IC/Ext               |
|   | Pressure max [bar]:                                   | 80                   |
| <b>8 019 51 002</b>   | <b>Axial drilling and milling head CHC</b>            |                      |
|  | Weight [kg]:  | 6.880                |
|   | Notation:   | IC-300               |
|   | Version:  | no Splash-protection |
|   | Tool drive:   | Flat (~DIN 1809)     |
|   | Shank size [mm]:                                      | 55.00                |
|   | Shank type:   | BMT                  |
|   | Tool adaption:  | CHC                  |
|   | Gear ratio [i]:                                       | 1:1,5                |
|   | Rotation max [1/min]:                                 | 18000                |
|   | Rotating direction:                                   | same                 |
|   | Coolant:  | no                   |
|   | Center distance [mm]:                                 | 77                   |

| Part-#              | Name  |                         |
|---------------------|---|-------------------------|
| <b>8 019 53 004</b> | <b>Axial drilling and milling head ER 11 AX IC</b>    |                         |
|                     | Weight [kg]:  | 9.380                   |
|                     | Notation:   | 180° reversible         |
|                     | Version:  | Special                 |
|                     | Tool drive:   | Flat (~DIN 1809)        |
|                     | Shank size [mm]:                                      | 55.00                   |
|                     | Shank type:   | BMT                     |
|                     | Tool adaption:  | ER 11 A                 |
|                     | Gear ratio [i]:                                       | 1:3                     |
|                     | Torque max [Nm]:                                      | 12                      |
|                     | Rotation max [1/min]:                                 | 12000                   |
|                     | Rotating direction:                                   | opposite                |
|                     | Coolant:  | IC/Ext                  |
|                     | Pressure max [bar]:                                   | 140                     |
|                     | Center distance [mm]:                                 | 90                      |
|                     | Offset [mm]:  | 134                     |
| <b>8 019 54 000</b> | <b>Axial drilling and milling head ER 20</b>          |                         |
|                     | Notation:   | offset                  |
|                     | Tool drive:   | Flat (~DIN 1809)        |
|                     | Shank size [mm]:                                      | 55.00                   |
|                     | Shank type:   | BMT                     |
|                     | Tool adaption:  | ER 20                   |
|                     | Gear ratio [i]:                                       | 1:3                     |
|                     | Torque max [Nm]:                                      | 10                      |
|                     | Rotation max [1/min]:                                 | 12000                   |
|                     | Rotating direction:                                   | opposite                |
|                     | Coolant:  | EXT                     |
|                     | Please note:  | 180° reversible         |
|                     | Offset [mm]:  | 42                      |
| <b>8 019 54 021</b> | <b>Axial drilling and milling head ER 20 AX UT</b>    |                         |
|                     | Weight [kg]:  | 5.420                   |
|                     | Notation:   | offset; 180° reversible |
|                     | Tool drive:   | Flat (~DIN 1809)        |
|                     | Shank size [mm]:                                      | 55.00                   |
|                     | Shank type:   | BMT                     |
|                     | Tool adaption:  | ER 20 A - u-tec         |
|                     | Gear ratio [i]:                                       | 1:1                     |
|                     | Torque max [Nm]:                                      | 32                      |
|                     | Rotation max [1/min]:                                 | 6000                    |
|                     | Rotating direction:                                   | same                    |
|                     | Coolant:  | EXT                     |
|                     | Please note:  | stronger bearing        |
|                     | Offset [mm]:  | 75                      |
| <b>8 019 54 028</b> | <b>Axial drilling and milling head ER 20 AX UT IC</b> |                         |
|                     | Notation:   | offset; 180° reversible |
|                     | Tool drive:   | Flat (~DIN 1809)        |
|                     | Shank size [mm]:                                      | 55.00                   |
|                     | Shank type:   | BMT                     |
|                     | Tool adaption:  | ER 20 A - u-tec         |
|                     | Gear ratio [i]:                                       | 1:1                     |
|                     | Torque max [Nm]:                                      | 32                      |
|                     | Rotation max [1/min]:                                 | 6000                    |
|                     | Rotating direction:                                   | same                    |
|                     | Coolant:  | IC/Ext                  |
|                     | Pressure max [bar]:                                   | 140                     |

# Nakamura



## Super NTJ-unterer Revolver

| Part-#  | Name   |                         |
|---|--|-------------------------|
|   | Please note:                                       | stronger bearing        |
|   | Offset [mm]:                                       | 75                      |
| <b>8 019 54 029</b>   | <b>Axial milling head universal arbor 16</b>       |                         |
|   | Notation:  | offset, 180° reversible |
|   | Tool drive:  | Flat (~DIN 1809)        |
|   | Shank size [mm]:                                   | 55.00                   |
|   | Shank type:  | BMT                     |
|   | Tool adaption:                                     | Universal arbor 16      |
|   | Gear ratio [i]:                                    | 2:1                     |
|   | Torque max [Nm]:                                   | 50                      |
|   | Rotation max [1/min]:                              | 3000                    |
|   | Rotating direction:                                | same                    |
|   | Coolant:   | EXT                     |
|   | Please note:                                       | Combi bearing           |
|   | Offset [mm]:                                       | 42                      |
| <b>8 019 54 031</b>   | <b>Axial drilling and milling head ER 20 AX UT</b> |                         |
|   | Weight [kg]:                                       | 5.230                   |
|   | Notation:  | offset; 180° reversible |
|   | Tool drive:  | Flat (~DIN 1809)        |
|   | Shank size [mm]:                                   | 55.00                   |
|   | Shank type:  | BMT                     |
|   | Tool adaption:                                     | ER 20 A - u-tec         |
|   | Gear ratio [i]:                                    | 1:3                     |
|   | Torque max [Nm]:                                   | 16                      |
|   | Rotation max [1/min]:                              | 18000                   |
|   | Rotating direction:                                | opposite                |
|   | Coolant:   | EXT                     |
|   | Offset [mm]:                                       | 42                      |
| <b>8 019 54 055</b>   | <b>Axial drilling and milling head ER 16 M IC</b>  |                         |
|  | Weight [kg]:                                       | 6.200                   |
|   | Notation:  | offset; 180° reversible |
|   | Tool drive:  | Flat (~DIN 1809)        |
|   | Shank size [mm]:                                   | 55.00                   |
|   | Shank type:  | BMT                     |
|   | Tool adaption:                                     | ER 16 M                 |
|   | Gear ratio [i]:                                    | 1:2                     |
|   | Torque max [Nm]:                                   | 25                      |
|   | Rotation max [1/min]:                              | 12000                   |
|   | Rotating direction:                                | opposite                |
|   | Coolant:   | IC/Ext                  |
|   | Pressure max [bar]:                                | 140                     |
|   | Please note:                                       | stronger bearing        |
|   | Offset [mm]:                                       | 42                      |
| <b>8 019 55 007</b>   | <b>Axial milling head arbor 22</b>                 |                         |
|   | Notation:  | offset                  |
|   | Version:   | Y-axes offset           |
|   | Tool drive:  | Flat (~DIN 1809)        |
|   | Shank size [mm]:                                   | 55.00                   |
|   | Shank type:  | BMT                     |
|   | Tool adaption:                                     | Arbor 22                |
|   | Gear ratio [i]:                                    | 2:1                     |
|   | Torque max [Nm]:                                   | 40                      |
|   | Rotation max [1/min]:                              | 3000                    |

| Part-#  | Name  |                         |
|---|---|-------------------------|
|   | Rotating direction:                                   | opposite                |
|   | Coolant:  | EXT                     |
|   | Please note:  | stronger bearing        |
|   | Offset [mm]:  | 34,5                    |
| <b>8 019 55 018</b>   | <b>Axial drilling and milling head ER 25 AX UT</b>    |                         |
|    | Weight [kg]:  | 5.230                   |
|   | Notation:   | offset; 180° reversible |
|   | Tool drive:   | Flat (~DIN 1809)        |
|   | Shank size [mm]:                                      | 55.00                   |
|   | Shank type:   | BMT                     |
|   | Tool adaption:  | ER 25 A - u-tec         |
|   | Gear ratio [i]:                                       | 1:1                     |
|   | Torque max [Nm]:                                      | 40                      |
|   | Rotation max [1/min]:                                 | 6000                    |
|   | Rotating direction:                                   | opposite                |
|   | Coolant:  | EXT                     |
|   | Please note:  | stronger bearing        |
|   | Offset [mm]:  | 42                      |
| <b>8 019 55 023</b>   | <b>Axial drilling and milling head ER 25 AX UT IC</b> |                         |
|  | Weight [kg]:  | 6.260                   |
|   | Notation:   | offset; 180° reversible |
|   | Tool drive:   | Flat (~DIN 1809)        |
|   | Shank size [mm]:                                      | 55.00                   |
|   | Shank type:   | BMT                     |
|   | Tool adaption:  | ER 25 A - u-tec         |
|   | Gear ratio [i]:                                       | 1:1                     |
|   | Torque max [Nm]:                                      | 40                      |
|   | Rotation max [1/min]:                                 | 6000                    |
|   | Rotating direction:                                   | opposite                |
|   | Coolant:  | IC/Ext                  |
|   | Pressure max [bar]:                                   | 140                     |
|   | Please note:  | stronger bearing        |
|   | Offset [mm]:  | 42                      |
| <b>8 019 55 024</b>   | <b>Axial drilling and milling head ER 25 AX UT</b>    |                         |
|  | Weight [kg]:  | 5.230                   |
|   | Notation:   | offset; 180° reversible |
|   | Tool drive:   | Flat (~DIN 1809)        |
|   | Shank size [mm]:                                      | 55.00                   |
|   | Shank type:   | BMT                     |
|   | Tool adaption:  | ER 25 A - u-tec         |
|   | Gear ratio [i]:                                       | 1:2                     |
|   | Torque max [Nm]:                                      | 25                      |
|   | Rotation max [1/min]:                                 | 12000                   |
|   | Rotating direction:                                   | opposite                |
|   | Coolant:  | EXT                     |
|   | Please note:  | stronger bearing        |
|   | Offset [mm]:  | 42                      |

# Nakamura

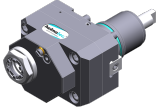
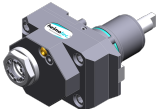
## Super NTJ-unterer Revolver

| Part-#  | Name  |                         |
|---|---|-------------------------|
| <b>8 019 55 025</b>   | <b>Axial drilling and milling head ER 25 AX UT IC</b> |                         |
|    | Weight [kg]:  | 6.330                   |
|   | Notation:   | offset; 180° reversible |
|   | Tool drive:   | Flat (~DIN 1809)        |
|   | Shank size [mm]:                                      | 55.00                   |
|   | Shank type:   | BMT                     |
|   | Tool adaption:  | ER 25 A - u-tec         |
|   | Gear ratio [i]:                                       | 1:2                     |
|   | Torque max [Nm]:                                      | 25                      |
|   | Rotation max [1/min]:                                 | 12000                   |
|   | Rotating direction:                                   | opposite                |
|   | Coolant:  | IC/Ext                  |
|   | Pressure max [bar]:                                   | 140                     |
|   | Please note:  | stronger bearing        |
|   | Offset [mm]:  | 42                      |
| <b>8 019 55 026</b>   | <b>Axial drilling and milling head ER 25 AX UT</b>    |                         |
|   | Weight [kg]:  | 5.300                   |
|   | Notation:   | offset; 180° reversible |
|   | Tool drive:   | Flat (~DIN 1809)        |
|   | Shank size [mm]:                                      | 55.00                   |
|   | Shank type:   | BMT                     |
|   | Tool adaption:  | ER 25 A - u-tec         |
|   | Gear ratio [i]:                                       | 1:3                     |
|   | Torque max [Nm]:                                      | 16                      |
|   | Rotation max [1/min]:                                 | 18000                   |
|   | Rotating direction:                                   | opposite                |
|   | Coolant:  | EXT                     |
|   | Please note:  | stronger bearing        |
|   | Offset [mm]:  | 42                      |
| <b>8 019 55 027</b>   | <b>Axial drilling and milling head ER 25 AX UT IC</b> |                         |
|  | Weight [kg]:  | 6.350                   |
|   | Notation:   | offset; 180° reversible |
|   | Tool drive:   | Flat (~DIN 1809)        |
|   | Shank size [mm]:                                      | 55.00                   |
|   | Shank type:   | BMT                     |
|   | Tool adaption:  | ER 25 A - u-tec         |
|   | Gear ratio [i]:                                       | 1:3                     |
|   | Torque max [Nm]:                                      | 16                      |
|   | Rotation max [1/min]:                                 | 18000                   |
|   | Rotating direction:                                   | opposite                |
|   | Coolant:  | IC/Ext                  |
|   | Pressure max [bar]:                                   | 140                     |
|   | Please note:  | stronger bearing        |
|   | Offset [mm]:  | 42                      |
| <b>8 019 55 028</b>   | <b>Axial drilling and milling head ER 25 AX UT</b>    |                         |
|  | Weight [kg]:  | 5.240                   |
|   | Notation:   | offset; 180° reversible |
|   | Tool drive:   | Flat (~DIN 1809)        |
|   | Shank size [mm]:                                      | 55.00                   |
|   | Shank type:   | BMT                     |
|   | Tool adaption:  | ER 25 A - u-tec         |
|   | Gear ratio [i]:                                       | 2:1                     |
|   | Torque max [Nm]:                                      | 50                      |

# Nakamura

## Super NTJ-unterer Revolver

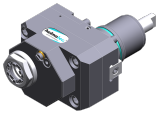
| Part-#  | Name  |                         |
|---|---|-------------------------|
|   | Rotation max [1/min]:                                 | 3000                    |
|   | Rotating direction:                                   | opposite                |
|   | Coolant:  | EXT                     |
|   | Please note:  | stronger bearing        |
|   | Offset [mm]:  | 42                      |
| <b>8 019 55 029</b>   | <b>Axial drilling and milling head ER 25 AX UT IC</b> |                         |
|  | Weight [kg]:  | 6.220                   |
|   | Notation:   | offset; 180° reversible |
|   | Tool drive:   | Flat (~DIN 1809)        |
|   | Shank size [mm]:                                      | 55.00                   |
|   | Shank type:   | BMT                     |
|   | Tool adaption:  | ER 25 A - u-tec         |
|   | Gear ratio [i]:                                       | 2:1                     |
|   | Torque max [Nm]:                                      | 50                      |
|   | Rotation max [1/min]:                                 | 3000                    |
|   | Rotating direction:                                   | opposite                |
|   | Coolant:  | IC/Ext                  |
|   | Pressure max [bar]:                                   | 140                     |
|   | Please note:  | stronger bearing        |
|   | Offset [mm]:  | 42                      |
| <b>8 019 55 045</b>   | <b>Axial drilling and milling head ER 25 AX UT IC</b> |                         |
|   | Weight [kg]:  | 6.350                   |
|   | Notation:   | offset; 180° reversible |
|   | Version:  | Special                 |
|   | Tool drive:   | Flat (~DIN 1809)        |
|   | Shank size [mm]:                                      | 55.00                   |
|   | Shank type:   | BMT                     |
|   | Tool adaption:  | ER 25 A - u-tec         |
|   | Gear ratio [i]:                                       | 1:3                     |
|   | Torque max [Nm]:                                      | 16                      |
|   | Rotation max [1/min]:                                 | 18000                   |
|   | Rotating direction:                                   | opposite                |
|   | Coolant:  | IC/Ext                  |
|   | Pressure max [bar]:                                   | 140                     |
|   | Offset [mm]:  | 42                      |
| <b>8 019 55 087</b>   | <b>Axial milling head universal arbor 22</b>          |                         |
|   | Weight [kg]:  | 5.480                   |
|   | Notation:   | offset, 180° reversible |
|   | Tool drive:   | Flat (~DIN 1809)        |
|   | Shank size [mm]:                                      | 55.00                   |
|   | Shank type:   | BMT                     |
|   | Tool adaption:  | Universal arbor 22      |
|   | Gear ratio [i]:                                       | 2:1                     |
|   | Torque max [Nm]:                                      | 50                      |
|   | Rotation max [1/min]:                                 | 3000                    |
|   | Rotating direction:                                   | opposite                |
|   | Coolant:  | EXT                     |
|   | Please note:  | Combi bearing           |
|   | Offset [mm]:  | 42                      |

| Part-# | Name |
|--------|------|
|--------|------|

8 019 56 038



**Axial drilling and milling head C 4**

Weight [kg]: 6.930  
 Notation: 180° reversible  
 Tool drive: Flat (~DIN 1809)  
 Shank size [mm]: 55.00  
 Shank type: BMT  
 Tool adaption: heimatec Capto(TM) C 4  
 Gear ratio [i]: 1:1  
 Torque max [Nm]: 50  
 Rotation max [1/min]: 6000  
 Rotating direction: opposite  
 Coolant: EXT  
 Please note: Check applicability; note tool length!  
 Offset [mm]: 62

8 019 56 042

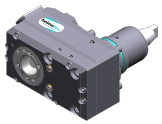

**Axial drilling and milling head C 4 IC**

Weight [kg]: 7.720  
 Notation: 180° reversible  
 Tool drive: Flat (~DIN 1809)  
 Shank size [mm]: 55.00  
 Shank type: BMT  
 Tool adaption: heimatec Capto(TM) C 4  
 Gear ratio [i]: 1:1  
 Torque max [Nm]: 50  
 Rotation max [1/min]: 6000  
 Rotating direction: opposite  
 Coolant: IC/Ext  
 Pressure max [bar]: 140  
 Please note: Check applicability; note tool length!  
 Offset [mm]: 62

8 019 56 057

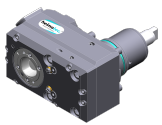

**Axial drilling and milling head C 4 IC**

Weight [kg]: 7.650  
 Notation: 180° reversible  
 Tool drive: Flat (~DIN 1809)  
 Shank size [mm]: 55.00  
 Shank type: BMT  
 Tool adaption: heimatec Capto(TM) C 4  
 Gear ratio [i]: 1:1  
 Torque max [Nm]: 50  
 Rotation max [1/min]: 12000  
 Rotating direction: opposite  
 Coolant: IC/Ext  
 Pressure max [bar]: 140  
 Please note: Check applicability; note tool length!  
 Offset [mm]: 62

8 030 53 005





**Radial drilling and milling head ER 11**

Weight [kg]: 5.210  
 Notation: 180° reversible  
 Tool drive: Flat (~DIN 1809)  
 Shank size [mm]: 55.00  
 Shank type: BMT  
 Tool adaption: ER 11  
 Gear ratio [i]: 1:4  
 Torque max [Nm]: 2,5

# Nakamura

## Super NTJ-unterer Revolver

| Part-#  | Name   |                        |
|---|--|------------------------|
|   | Rotation max [1/min]:                                  | 48000                  |
|   | Rotating direction:                                    | opposite               |
|   | Coolant:   | EXT                    |
|   | Please note:   | Check applicability!   |
|   | Center distance [mm]:                                  | 65                     |
| <b>8 030 54 001</b>   | <b>Radial drilling and milling head ER 20</b>          |                        |
|    | Weight [kg]:   | 4.750                  |
|   | Tool drive:  | Flat (~DIN 1809)       |
|   | Shank size [mm]:                                       | 55.00                  |
|   | Shank type:  | BMT                    |
|   | Tool adaption:   | ER 20                  |
|   | Gear ratio [i]:  | 1:1                    |
|   | Torque max [Nm]:                                       | 25                     |
|   | Rotation max [1/min]:                                  | 6000                   |
|   | Rotating direction:                                    | opposite               |
|   | Coolant:   | EXT                    |
|   | Center distance [mm]:                                  | 55                     |
| <b>8 030 54 043</b>   | <b>Radial drilling and milling head Weldon 12 IC</b>   |                        |
|   | Notation:  | 180° reversible        |
|   | Version:   | Special                |
|   | Tool drive:  | Flat (~DIN 1809)       |
|   | Shank size [mm]:                                       | 55.00                  |
|   | Shank type:  | BMT                    |
|   | Tool adaption:   | Weldon (DIN 1835 b) 12 |
|   | Gear ratio [i]:  | 1:1                    |
|   | Torque max [Nm]:                                       | 50                     |
|   | Rotation max [1/min]:                                  | 6000                   |
|   | Rotating direction:                                    | opposite               |
|   | Coolant:   | IC/Ext                 |
|   | Pressure max [bar]:                                    | 140                    |
|   | Please note:   | Combi bearing          |
|   | Center distance [mm]:                                  | 75                     |
| <b>8 030 54 048</b>   | <b>Radial drilling and milling head ER 16 AX UT</b>    |                        |
|   | Weight [kg]:   | 6.320                  |
|   | Notation:  | 180° reversible        |
|   | Tool drive:  | Flat (~DIN 1809)       |
|   | Shank size [mm]:                                       | 55.00                  |
|   | Shank type:  | BMT                    |
|   | Tool adaption:   | ER 16 A - u-tec        |
|   | Gear ratio [i]:  | 1:3                    |
|   | Torque max [Nm]:                                       | 12                     |
|   | Rotation max [1/min]:                                  | 18000                  |
|   | Rotating direction:                                    | same                   |
|   | Coolant:   | EXT                    |
|   | Please note:   | stronger bearing       |
|   | Center distance [mm]:                                  | 77                     |
| <b>8 030 54 049</b>   | <b>Radial drilling and milling head ER 16 AX UT IC</b> |                        |
|  | Weight [kg]:   | 6.500                  |
|   | Notation:  | 180° reversible        |
|   | Tool drive:  | Flat (~DIN 1809)       |
|   | Shank size [mm]:                                       | 55.00                  |
|   | Shank type:  | BMT                    |
|   | Tool adaption:   | ER 16 A - u-tec        |

| Part-# | Name |
|--------|------|
|--------|------|

Gear ratio [i]: 1:1  
 Torque max [Nm]: 50  
 Rotation max [1/min]: 6000  
 Rotating direction: opposite  
 Coolant: IC/Ext  
 Pressure max [bar]: 140  
 Please note: Combi bearing; high pressure version  
 Center distance [mm]: 65

**8 030 54 050 Radial drilling and milling head ER 16 AX UT IC**



Notation: 180° reversible  
 Tool drive: Flat (~DIN 1809)  
 Shank size [mm]: 55.00  
 Shank type: BMT  
 Tool adaption: ER 16 A - u-tec  
 Gear ratio [i]: 1:4  
 Torque max [Nm]: 5  
 Rotation max [1/min]: 24000  
 Rotating direction: opposite  
 Coolant: IC/Ext  
 Pressure max [bar]: 140  
 Center distance [mm]: 65

**8 030 54 056 Radial drilling and milling head ER 20 AX UT IC**



Weight [kg]: 5.320  
 Tool drive: Flat (~DIN 1809)  
 Shank size [mm]: 55.00  
 Shank type: BMT  
 Tool adaption: ER 20 A - u-tec  
 Gear ratio [i]: 1:1  
 Torque max [Nm]: 25  
 Rotation max [1/min]: 6000  
 Rotating direction: opposite  
 Coolant: IC/Ext  
 Pressure max [bar]: 140  
 Please note: Combi bearing  
 Center distance [mm]: 55

**8 030 54 064 Radial drilling and milling head ER 20 AX UT IC**



Weight [kg]: 6.520  
 Notation: 180° reversible  
 Tool drive: Flat (~DIN 1809)  
 Shank size [mm]: 55.00  
 Shank type: BMT  
 Tool adaption: ER 20 A - u-tec  
 Gear ratio [i]: 1:2  
 Torque max [Nm]: 16  
 Rotation max [1/min]: 12000  
 Rotating direction: same  
 Coolant: IC/Ext  
 Pressure max [bar]: 140  
 Please note: stronger bearing  
 Center distance [mm]: 77

| Part-#   | Name   |   |
|--|--|---|
| <b>8 030 55 004</b><br>   | <b>Radial drilling and milling head ER 25 IC</b>   |   |
|  | Weight [kg]:   | 5.200   |
|  | Tool drive:  | Flat (~DIN 1809)                                    |
|  | Shank size [mm]:   | 55.00   |
|  | Shank type:  | BMT   |
|  | Tool adaption:   | ER 25   |
|  | Gear ratio [i]:  | 1:1   |
|  | Torque max [Nm]:   | 25  |
|  | Rotation max [1/min]:  | 6000  |
|  | Rotating direction:  | opposite  |
|  | Coolant:   | IC/Ext  |
|  | Pressure max [bar]:  | 140   |
|  | Center distance [mm]:  | 55  |
| <b>8 030 55 007</b><br>   | <b>Radial drilling and milling head ER 25</b>  |   |
|  | Weight [kg]:   | 4.770   |
|  | Tool drive:  | Flat (~DIN 1809)                                    |
|  | Shank size [mm]:   | 55.00   |
|  | Shank type:  | BMT   |
|  | Tool adaption:   | ER 25   |
|  | Gear ratio [i]:  | 1:1   |
|  | Torque max [Nm]:   | 25  |
|  | Rotation max [1/min]:  | 6000  |
|  | Rotating direction:  | opposite  |
|  | Coolant:   | EXT   |
|  | Center distance [mm]:  | 55  |
|  | <b>8 030 55 063</b><br> | <b>Radial drilling and milling head ER 25 AX UT</b> |
| Notation:  |  | 180° reversible                                     |
| Tool drive:  |  | Flat (~DIN 1809)                                    |
| Shank size [mm]:   |  | 55.00   |
| Shank type:  |  | BMT   |
| Tool adaption:   |  | ER 25 A - u-tec                                     |
| Gear ratio [i]:  |  | 2:1   |
| Torque max [Nm]:   |  | 63  |
| Rotation max [1/min]:  |  | 6000  |
| Rotating direction:  |  | opposite  |
| Coolant:   |  | EXT   |
| Please note:   |  | Combi bearing                                       |
| Center distance [mm]:  |  | 65  |
| <b>8 030 55 081</b><br> | <b>Angle-mill- and drill holder ER 25 AX UT IC</b>   |   |
|  | Weight [kg]:   | 7.150   |
|  | Notation:  | 180° reversible                                     |
|  | Tool drive:  | Flat (~DIN 1809)                                    |
|  | Shank size [mm]:   | 55.00   |
|  | Shank type:  | BMT   |
|  | Tool adaption:   | ER 25 A - u-tec                                     |
|  | Gear ratio [i]:  | 1:1   |
|  | Torque max [Nm]:   | 50  |
|  | Rotation max [1/min]:  | 6000  |
|  | Rotating direction:  | opposite  |
|  | Coolant:   | IC/Ext  |
|  | Pressure max [bar]:  | 140   |
| Please note:   | Combi bearing  |   |
| Center distance [mm]:  | 75   |   |

| Part-# | Name |
|--------|------|
|--------|------|

**8 030 55 087**



**Radial drilling and milling head Weldon 3/4"**

|                       |                                    |
|-----------------------|------------------------------------|
| Weight [kg]:          | 6.690                              |
| Notation:             | 180° reversible                    |
| Tool drive:           | Flat (~DIN 1809)                   |
| Shank size [mm]:      | 55.00                              |
| Shank type:           | BMT                                |
| Tool adaption:        | Weldon (DIN 1835 b) 3/4" (19,05mm) |
| Gear ratio [i]:       | 1:1                                |
| Torque max [Nm]:      | 50                                 |
| Rotation max [1/min]: | 6000                               |
| Rotating direction:   | opposite                           |
| Coolant:              | EXT                                |
| Please note:          | Combi bearing                      |
| Center distance [mm]: | 65                                 |

**8 030 55 091**

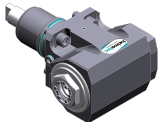

**Angle-mill- and drill holder ER 25 AX UT IC**

|                       |                                      |
|-----------------------|--------------------------------------|
| Weight [kg]:          | 6.680                                |
| Notation:             | 180° reversible                      |
| Tool drive:           | Flat (~DIN 1809)                     |
| Shank size [mm]:      | 55.00                                |
| Shank type:           | BMT                                  |
| Tool adaption:        | ER 25 A - u-tec                      |
| Gear ratio [i]:       | 1:1                                  |
| Torque max [Nm]:      | 50                                   |
| Rotation max [1/min]: | 6000                                 |
| Rotating direction:   | opposite                             |
| Coolant:              | IC/Ext                               |
| Pressure max [bar]:   | 140                                  |
| Please note:          | Combi bearing; high pressure version |
| Center distance [mm]: | 65                                   |

**8 030 55 092**



**Angle-mill- and drill holder ER 25 AX UT**

|                       |                  |
|-----------------------|------------------|
| Weight [kg]:          | 6.320            |
| Notation:             | 180° reversible  |
| Tool drive:           | Flat (~DIN 1809) |
| Shank size [mm]:      | 55.00            |
| Shank type:           | BMT              |
| Tool adaption:        | ER 25 A - u-tec  |
| Gear ratio [i]:       | 1:1              |
| Torque max [Nm]:      | 50               |
| Rotation max [1/min]: | 6000             |
| Rotating direction:   | opposite         |
| Coolant:              | EXT              |
| Please note:          | Combi bearing    |
| Center distance [mm]: | 65               |

**8 030 55 122**

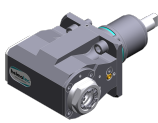



**Radial drilling and milling head ER 25 AX UT**

|                       |                  |
|-----------------------|------------------|
| Weight [kg]:          | 6.380            |
| Notation:             | 180° reversible  |
| Tool drive:           | Flat (~DIN 1809) |
| Shank size [mm]:      | 55.00            |
| Shank type:           | BMT              |
| Tool adaption:        | ER 25 A - u-tec  |
| Gear ratio [i]:       | 1:2              |
| Torque max [Nm]:      | 16               |
| Rotation max [1/min]: | 12000            |

# Nakamura

## Super NTJ-unterer Revolver

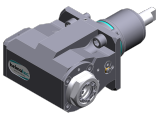
| Part-#  | Name   |  |
|---|--|--|
|   | Rotating direction:                                    | same                                   |
|   | Coolant:   | EXT                                    |
|   | Please note:   | stronger bearing; check applicability; |
|   | Center distance [mm]:                                  | 77                                     |
| <b>8 030 55 123</b>   | <b>Radial drilling and milling head ER 25 AX UT IC</b> |  |
|    | Weight [kg]:   | 6.550                                  |
|   | Notation:  | 180° reversible                        |
|   | Tool drive:  | Flat (~DIN 1809)                       |
|   | Shank size [mm]:                                       | 55.00                                  |
|   | Shank type:  | BMT                                    |
|   | Tool adaption:   | ER 25 A - u-tec                        |
|   | Gear ratio [i]:  | 1:2                                    |
|   | Torque max [Nm]:                                       | 16                                     |
|   | Rotation max [1/min]:                                  | 12000                                  |
|   | Rotating direction:                                    | same                                   |
|   | Coolant:   | IC/Ext                                 |
|   | Pressure max [bar]:                                    | 140                                    |
|   | Please note:   | stronger bearing                       |
|   | Center distance [mm]:                                  | 77                                     |
| <b>8 030 55 131</b>   | <b>Radial drilling and milling head ER 25 AX UT</b>    |  |
|  | Weight [kg]:   | 4.980                                  |
|   | Tool drive:  | Flat (~DIN 1809)                       |
|   | Shank size [mm]:                                       | 55.00                                  |
|   | Shank type:  | BMT                                    |
|   | Tool adaption:   | ER 25 A - u-tec                        |
|   | Gear ratio [i]:  | 1:1                                    |
|   | Torque max [Nm]:                                       | 25                                     |
|   | Rotation max [1/min]:                                  | 6000                                   |
|   | Rotating direction:                                    | opposite                               |
|   | Coolant:   | EXT                                    |
|   | Please note:   | stronger bearing                       |
|   | Center distance [mm]:                                  | 55                                     |
| <b>8 030 55 139</b>   | <b>Radial drilling and milling head ER 25 AX UT IC</b> |  |
|  | Weight [kg]:   | 6.560                                  |
|   | Notation:  | 180° reversible                        |
|   | Tool drive:  | Flat (~DIN 1809)                       |
|   | Shank size [mm]:                                       | 55.00                                  |
|   | Shank type:  | BMT                                    |
|   | Tool adaption:   | ER 25 A - u-tec                        |
|   | Gear ratio [i]:  | 1:3                                    |
|   | Torque max [Nm]:                                       | 12                                     |
|   | Rotation max [1/min]:                                  | 18000                                  |
|   | Rotating direction:                                    | same                                   |
|   | Coolant:   | IC/Ext                                 |
|   | Pressure max [bar]:                                    | 140                                    |
|   | Please note:   | stronger bearing                       |
|   | Center distance [mm]:                                  | 77                                     |

# Nakamura

## Super NTJ-unterer Revolver

| Part-#              | Name   |   |
|---------------------|--|---|
| <b>8 030 55 140</b> | <b>Radial drilling and milling head ER 25 AX UT</b>    |   |
|                     | Weight [kg]:   | 6.700                                   |
|                     | Notation:  | 180° reversible                         |
|                     | Tool drive:  | Flat (~DIN 1809)                        |
|                     | Shank size [mm]:                                       | 55.00                                   |
|                     | Shank type:  | BMT                                     |
|                     | Tool adaption:   | ER 25 A - u-tec                         |
|                     | Gear ratio [i]:  | 1:3                                     |
|                     | Torque max [Nm]:                                       | 12                                      |
|                     | Rotation max [1/min]:                                  | 18000                                   |
|                     | Rotating direction:                                    | same                                    |
|                     | Coolant:   | EXT                                     |
|                     | Please note:   | stronger bearing                        |
|                     | Center distance [mm]:                                  | 77                                      |
| <b>8 030 55 154</b> | <b>Radial drilling and milling head ER 25 AX UT IC</b> |   |
|                     | Weight [kg]:   | 5.390                                   |
|                     | Tool drive:  | Flat (~DIN 1809)                        |
|                     | Shank size [mm]:                                       | 55.00                                   |
|                     | Shank type:  | BMT                                     |
|                     | Tool adaption:   | ER 25 A - u-tec                         |
|                     | Gear ratio [i]:  | 1:1                                     |
|                     | Torque max [Nm]:                                       | 25                                      |
|                     | Rotation max [1/min]:                                  | 6000                                    |
|                     | Rotating direction:                                    | opposite                                |
|                     | Coolant:   | IC/Ext                                  |
|                     | Pressure max [bar]:                                    | 140                                     |
|                     | Please note:   | High pressure version, stronger bearing |
|                     | Center distance [mm]:                                  | 55                                      |
| <b>8 030 55 158</b> | <b>Radial drilling and milling head C 3 IC</b>         |   |
|                     | Weight [kg]:   | 8.280                                   |
|                     | Notation:  | 180° reversible                         |
|                     | Tool drive:  | Flat (~DIN 1809)                        |
|                     | Shank size [mm]:                                       | 55.00                                   |
|                     | Shank type:  | BMT                                     |
|                     | Tool adaption:   | heimatec Capto(TM) C 3                  |
|                     | Gear ratio [i]:  | 1:1                                     |
|                     | Torque max [Nm]:                                       | 25                                      |
|                     | Rotation max [1/min]:                                  | 8000                                    |
|                     | Rotating direction:                                    | opposite                                |
|                     | Coolant:   | IC/Ext                                  |
|                     | Pressure max [bar]:                                    | 140                                     |
|                     | Please note:   | Check applicability; note tool length!  |
|                     | Center distance [mm]:                                  | 65                                      |
| <b>8 030 55 159</b> | <b>Radial drilling and milling head ER 25 AX UT</b>    |   |
|                     | Weight [kg]:   | 7.710                                   |
|                     | Notation:  | 180° reversible                         |
|                     | Tool drive:  | Flat (~DIN 1809)                        |
|                     | Shank size [mm]:                                       | 55.00                                   |
|                     | Shank type:  | BMT                                     |
|                     | Tool adaption:   | ER 25 A - u-tec                         |
|                     | Gear ratio [i]:  | 1:3                                     |
|                     | Torque max [Nm]:                                       | 12                                      |
|                     | Rotation max [1/min]:                                  | 18000                                   |
|                     | Rotating direction:                                    | same                                    |
|                     | Coolant:   | EXT                                     |

| Part-# | Name |
|--------|------|
|--------|------|

Please note: stronger bearing  
Center distance [mm]: 107

**8 030 55 206 Radial drilling and milling head ER 25 AX UT IC**

Notation: 180° reversible  
Tool drive: Flat (~DIN 1809)  
Shank size [mm]: 55.00  
Shank type: BMT  
Tool adaption: ER 25 A - u-tec  
Gear ratio [i]: 1:2  
Torque max [Nm]: 16  
Rotation max [1/min]: 12000  
Rotating direction: same  
Coolant: IC/Ext  
Pressure max [bar]: 140  
Please note: strong bearing with hybrid-bearing  
Center distance [mm]: 77

**8 030 55 216 Angle-mill- and drill holder ER 25 AX UT**



Notation: 180° reversible  
Tool drive: Flat (~DIN 1809)  
Shank size [mm]: 55.00  
Shank type: BMT  
Tool adaption: ER 25 A - u-tec  
Gear ratio [i]: 1:1  
Torque max [Nm]: 50  
Rotation max [1/min]: 6000  
Rotating direction: opposite  
Coolant: EXT  
Please note: Combi bearing; check applicability  
Center distance [mm]: 95

**8 030 55 217 Angle-mill- and drill holder ER 25 AX UT IC**





Notation: 180° reversible  
Tool drive: Flat (~DIN 1809)  
Shank size [mm]: 55.00  
Shank type: BMT  
Tool adaption: ER 25 A - u-tec  
Gear ratio [i]: 1:1  
Torque max [Nm]: 50  
Rotation max [1/min]: 6000  
Rotating direction: opposite  
Coolant: IC/Ext  
Pressure max [bar]: 140  
Please note: Combi bearing; Einsetzbareit check!  
Center distance [mm]: 95

**8 030 55 238 Radial drilling and milling head ER 25 AX UT**

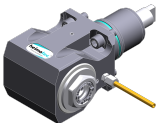
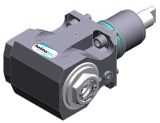

Weight [kg]: 6.100  
Notation: 180° reversible  
Tool drive: Flat (~DIN 1809)  
Shank size [mm]: 55.00  
Shank type: BMT  
Tool adaption: ER 25 A - u-tec  
Gear ratio [i]: 1:1  
Torque max [Nm]: 50  
Rotation max [1/min]: 12000

| Part-#  | Name   |                  |
|---|--|------------------|
|   | Rotating direction:                                    | opposite         |
|   | Coolant:   | EXT              |
|   | Center distance [mm]:                                  | 65               |
| <b>8 030 55 239</b>   | <b>Radial drilling and milling head ER 25 AX UT IC</b> |                  |
|    | Weight [kg]:   | 6.470            |
|   | Notation:  | 180° reversible  |
|   | Tool drive:  | Flat (~DIN 1809) |
|   | Shank size [mm]:                                       | 55.00            |
|   | Shank type:  | BMT              |
|   | Tool adaption:   | ER 25 A - u-tec  |
|   | Gear ratio [i]:  | 1:1              |
|   | Torque max [Nm]:                                       | 50               |
|   | Rotation max [1/min]:                                  | 12000            |
|   | Rotating direction:                                    | opposite         |
|   | Coolant:   | IC/Ext           |
|   | Pressure max [bar]:                                    | 140              |
|   | Center distance [mm]:                                  | 65               |
| <b>8 030 55 240</b>   | <b>Radial drilling and milling head ER 25 AX UT</b>    |                  |
|   | Weight [kg]:   | 6.380            |
|   | Notation:  | 180° reversible  |
|   | Tool drive:  | Flat (~DIN 1809) |
|   | Shank size [mm]:                                       | 55.00            |
|   | Shank type:  | BMT              |
|   | Tool adaption:   | ER 25 A - u-tec  |
|   | Gear ratio [i]:  | 1:1              |
|   | Torque max [Nm]:                                       | 50               |
|   | Rotation max [1/min]:                                  | 12000            |
|   | Rotating direction:                                    | opposite         |
|   | Coolant:   | EXT              |
|   | Center distance [mm]:                                  | 75               |
| <b>8 030 55 241</b>   | <b>Angle drilling and milling head ER 25 AX UT IC</b>  |                  |
|  | Weight [kg]:   | 6.960            |
|   | Notation:  | 180° reversible  |
|   | Tool drive:  | Flat (~DIN 1809) |
|   | Shank size [mm]:                                       | 55.00            |
|   | Shank type:  | BMT              |
|   | Tool adaption:   | ER 25 A - u-tec  |
|   | Gear ratio [i]:  | 1:1              |
|   | Torque max [Nm]:                                       | 50               |
|   | Rotation max [1/min]:                                  | 12000            |
|   | Rotating direction:                                    | opposite         |
|   | Coolant:   | IC/Ext           |
|   | Pressure max [bar]:                                    | 140              |
|   | Center distance [mm]:                                  | 75               |
| <b>8 030 55 244</b>   | <b>Angle-mill- and drill holder ER 25 AS UT</b>        |                  |
|   | Notation:  | 180° reversible  |
|   | Tool drive:  | Flat (~DIN 1809) |
|   | Shank size [mm]:                                       | 55.00            |
|   | Shank type:  | BMT              |
|   | Tool adaption:   | ER 25 A - u-tec  |
|   | Gear ratio [i]:  | 1:1              |
|   | Torque max [Nm]:                                       | 50               |
|   | Rotation max [1/min]:                                  | 6000             |

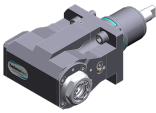
| Part-#  | Name   |  |
|---|--|--|
|   | Rotating direction:                                    | opposite                               |
|   | Coolant:   | EXT                                    |
|   | Please note:   | Combi bearing                          |
|   | Center distance [mm]:                                  | 65                                     |
| <b>8 030 55 246</b>   | <b>Radial drilling and milling head ER 25 AS UT</b>    |  |
|   | Notation:  | 180° reversible                        |
|   | Tool drive:  | Flat (~DIN 1809)                       |
|   | Shank size [mm]:                                       | 55.00                                  |
|   | Shank type:  | BMT                                    |
|   | Tool adaption:   | ER 25 A - u-tec                        |
|   | Gear ratio [i]:  | 1:1                                    |
|   | Torque max [Nm]:                                       | 50                                     |
|   | Rotation max [1/min]:                                  | 12000                                  |
|   | Rotating direction:                                    | opposite                               |
|   | Coolant:   | EXT                                    |
|   | Center distance [mm]:                                  | 65                                     |
| <b>8 030 55 247</b>   | <b>Radial drilling and milling head ER 25 AS UT IC</b> |  |
|   | Notation:  | 180° reversible                        |
|   | Tool drive:  | Flat (~DIN 1809)                       |
|   | Shank size [mm]:                                       | 55.00                                  |
|   | Shank type:  | BMT                                    |
|   | Tool adaption:   | ER 25 A - u-tec                        |
|   | Gear ratio [i]:  | 1:1                                    |
|   | Torque max [Nm]:                                       | 50                                     |
|   | Rotation max [1/min]:                                  | 12000                                  |
|   | Rotating direction:                                    | opposite                               |
|   | Coolant:   | IC/Ext                                 |
|   | Pressure max [bar]:                                    | 140                                    |
|   | Center distance [mm]:                                  | 65                                     |
| <b>8 030 55 250</b>   | <b>Radial drilling and milling head ER 25 AX UT IC</b> |  |
|  | Weight [kg]:   | 8.170                                  |
|   | Notation:  | 180° reversible                        |
|   | Tool drive:  | Flat (~DIN 1809)                       |
|   | Shank size [mm]:                                       | 55.00                                  |
|   | Shank type:  | BMT                                    |
|   | Tool adaption:   | ER 25 A - u-tec                        |
|   | Gear ratio [i]:  | 1:1                                    |
|   | Torque max [Nm]:                                       | 50                                     |
|   | Rotation max [1/min]:                                  | 12000                                  |
|   | Rotating direction:                                    | opposite                               |
|   | Coolant:   | IC/Ext                                 |
|   | Pressure max [bar]:                                    | 140                                    |
|   | Please note:   | Check applicability; note tool length! |
|   | Center distance [mm]:                                  | 100                                    |
| <b>8 030 55 251</b>   | <b>Radial drilling and milling head ER 25 AX UT IC</b> |  |
|  | Weight [kg]:   | 7.520                                  |
|   | Notation:  | 180° reversible                        |
|   | Tool drive:  | Flat (~DIN 1809)                       |
|   | Shank size [mm]:                                       | 55.00                                  |
|   | Shank type:  | BMT                                    |
|   | Tool adaption:   | ER 25 A - u-tec                        |
|   | Gear ratio [i]:  | 1:2                                    |
|   | Torque max [Nm]:                                       | 16                                     |

# Nakamura Super NTJ-unterer Revolver

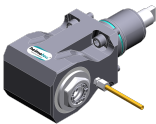
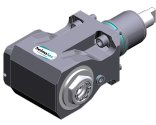
| Part-#  | Name   |  |
|---|--|--|
|   | Rotation max [1/min]:                                  | 16000                                  |
|   | Rotating direction:                                    | same                                   |
|   | Coolant:   | IC/Ext                                 |
|   | Pressure max [bar]:                                    | 140                                    |
|   | Please note:   | stronger bearing; check applicability; |
|   | Center distance [mm]:                                  | 100                                    |
| <b>8 030 55 262</b>   | <b>Radial drilling and milling head ER 25 AX UT</b>    |  |
|    | Weight [kg]:   | 7.500                                  |
|   | Notation:  | 180° reversible                        |
|   | Tool drive:  | Flat (~DIN 1809)                       |
|   | Shank size [mm]:                                       | 55.00                                  |
|   | Shank type:  | BMT                                    |
|   | Tool adaption:   | ER 25 A - u-tec                        |
|   | Gear ratio [i]:  | 1:1                                    |
|   | Torque max [Nm]:                                       | 50                                     |
|   | Rotation max [1/min]:                                  | 12000                                  |
|   | Rotating direction:                                    | opposite                               |
|   | Coolant:   | EXT                                    |
|   | Please note:   | Check applicability!                   |
|   | Center distance [mm]:                                  | 95                                     |
| <b>8 030 55 263</b>   | <b>Radial drilling and milling head ER 25 AX UT IC</b> |  |
|  | Weight [kg]:   | 7.980                                  |
|   | Notation:  | 180° reversible                        |
|   | Tool drive:  | Flat (~DIN 1809)                       |
|   | Shank size [mm]:                                       | 55.00                                  |
|   | Shank type:  | BMT                                    |
|   | Tool adaption:   | ER 25 A - u-tec                        |
|   | Gear ratio [i]:  | 1:1                                    |
|   | Torque max [Nm]:                                       | 50                                     |
|   | Rotation max [1/min]:                                  | 12000                                  |
|   | Rotating direction:                                    | opposite                               |
|   | Coolant:   | IC/Ext                                 |
|   | Pressure max [bar]:                                    | 140                                    |
|   | Please note:   | Check applicability!                   |
|   | Center distance [mm]:                                  | 95                                     |
| <b>8 030 56 013</b>   | <b>Radial drilling and milling head HT 4</b>           |  |
|   | Weight [kg]:   | 4.620                                  |
|   | Tool drive:  | Flat (~DIN 1809)                       |
|   | Shank size [mm]:                                       | 55.00                                  |
|   | Shank type:  | BMT                                    |
|   | Tool adaption:   | HT 4                                   |
|   | Gear ratio [i]:  | 1:1                                    |
|   | Torque max [Nm]:                                       | 25                                     |
|   | Rotation max [1/min]:                                  | 6000                                   |
|   | Rotating direction:                                    | opposite                               |
|   | Coolant:   | EXT                                    |
|   | Center distance [mm]:                                  | 55                                     |

| Part-# | Name |
|--------|------|
|--------|------|

|                       |   |
|-----------------------|---|
| <b>8 030 56 059</b>   | <b>Radial drilling and milling head HT 4 IC</b> |
| Notation:             | 180° reversible                                 |
| Version:              | long  |
| Tool drive:           | Flat (~DIN 1809)                                |
| Shank size [mm]:      | 55.00   |
| Shank type:           | BMT   |
| Tool adaption:        | HT 4  |
| Gear ratio [i]:       | 2:1   |
| Torque max [Nm]:      | 63  |
| Rotation max [1/min]: | 3000  |
| Rotating direction:   | opposite  |
| Coolant:              | IC/Ext  |
| Pressure max [bar]:   | 140   |
| Please note:          | Combi bearing                                   |
| Center distance [mm]: | 65  |

|  |   |
|--|---|
| <b>8 030 56 070</b>  | <b>Radial drilling and milling head ER 32 AX UT</b> |
|  |   |
| Notation:  | 180° reversible                                     |
| Tool drive:  | Flat (~DIN 1809)                                    |
| Shank size [mm]:   | 55.00   |
| Shank type:  | BMT   |
| Tool adaption:   | ER 32 A - u-tec                                     |
| Gear ratio [i]:  | 2:1   |
| Torque max [Nm]:   | 63  |
| Rotation max [1/min]:  | 6000  |
| Rotating direction:  | opposite  |
| Coolant:   | EXT   |
| Please note:   | Combi bearing                                       |
| Center distance [mm]:  | 65  |

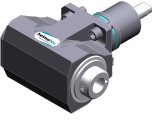
|   |   |
|---|---|
| <b>8 030 56 075</b>   | <b>Radial drilling and milling head HT 4 IC</b> |
|  |   |
| Weight [kg]:  | 6.580   |
| Notation:   | 180° reversible                                 |
| Tool drive:   | Flat (~DIN 1809)                                |
| Shank size [mm]:  | 55.00   |
| Shank type:   | BMT   |
| Tool adaption:  | HT 4  |
| Gear ratio [i]:   | 1:1   |
| Torque max [Nm]:  | 50  |
| Rotation max [1/min]:   | 6000  |
| Rotating direction:   | opposite  |
| Coolant:  | IC/Ext  |
| Pressure max [bar]:   | 140   |
| Please note:  | Combi bearing                                   |
| Center distance [mm]:   | 65  |

|   |   |
|---|---|
| <b>8 030 56 087</b>   | <b>Angle-mill- and drill holder ER 32 AX UT</b> |
|  |   |
| Weight [kg]:  | 6.880   |
| Notation:   | 180° reversible                                 |
| Tool drive:   | Flat (~DIN 1809)                                |
| Shank size [mm]:  | 55.00   |
| Shank type:   | BMT   |
| Tool adaption:  | ER 32 A - u-tec                                 |
| Gear ratio [i]:   | 1:1   |
| Torque max [Nm]:  | 50  |
| Rotation max [1/min]:   | 6000  |
| Rotating direction:   | opposite  |

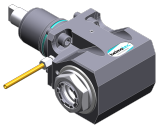
| Part-#  | Name   |                  |
|---|--|------------------|
|   | Coolant:   | EXT              |
|   | Please note:   | Combi bearing    |
|   | Center distance [mm]:                                  | 75               |
| <b>8 030 56 088</b>   | <b>Angle-mill- and drill holder ER 32 AX UT IC</b>     |                  |
|   | Notation:  | 180° reversible  |
|   | Tool drive:  | Flat (~DIN 1809) |
|   | Shank size [mm]:                                       | 55.00            |
|   | Shank type:  | BMT              |
|   | Tool adaption:   | ER 32 A - u-tec  |
|   | Gear ratio [i]:  | 1:1              |
|   | Torque max [Nm]:                                       | 50               |
|   | Rotation max [1/min]:                                  | 6000             |
|   | Rotating direction:                                    | opposite         |
|   | Coolant:   | IC/Ext           |
|   | Pressure max [bar]:                                    | 140              |
|   | Please note:   | Combi bearing    |
|   | Center distance [mm]:                                  | 75               |
| <b>8 030 56 090</b>   | <b>Radial drilling and milling head ER 32 AX UT IC</b> |                  |
|   | Notation:  | 180° reversible  |
|   | Tool drive:  | Flat (~DIN 1809) |
|   | Shank size [mm]:                                       | 55.00            |
|   | Shank type:  | BMT              |
|   | Tool adaption:   | ER 32 A - u-tec  |
|   | Gear ratio [i]:  | 2:1              |
|   | Torque max [Nm]:                                       | 63               |
|   | Rotation max [1/min]:                                  | 6000             |
|   | Rotating direction:                                    | opposite         |
|   | Coolant:   | IC/Ext           |
|   | Pressure max [bar]:                                    | 140              |
|   | Please note:   | Combi bearing    |
|   | Center distance [mm]:                                  | 65               |
| <b>8 030 56 092</b>   | <b>Radial drilling and milling head ER 32 AX UT</b>    |                  |
|  | Weight [kg]:   | 6.830            |
|   | Notation:  | 180° reversible  |
|   | Tool drive:  | Flat (~DIN 1809) |
|   | Shank size [mm]:                                       | 55.00            |
|   | Shank type:  | BMT              |
|   | Tool adaption:   | ER 32 A - u-tec  |
|   | Gear ratio [i]:  | 2:1              |
|   | Torque max [Nm]:                                       | 63               |
|   | Rotation max [1/min]:                                  | 3000             |
|   | Rotating direction:                                    | opposite         |
|   | Coolant:   | EXT              |
|   | Please note:   | Combi bearing    |
|   | Center distance [mm]:                                  | 75               |
| <b>8 030 56 093</b>   | <b>Radial drilling and milling head ER 32 AX UT IC</b> |                  |
|   | Weight [kg]:   | 7.040            |
|   | Notation:  | 180° reversible  |
|   | Tool drive:  | Flat (~DIN 1809) |
|   | Shank size [mm]:                                       | 55.00            |
|   | Shank type:  | BMT              |
|   | Tool adaption:   | ER 32 A - u-tec  |
|   | Gear ratio [i]:  | 2:1              |

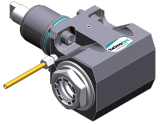
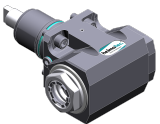
| Part-#  | Name   |   |
|---|--|---|
|   |  | Torque max [Nm]: 63<br>Rotation max [1/min]: 3000<br>Rotating direction: opposite<br>Coolant: IC/Ext<br>Pressure max [bar]: 140<br>Please note: Combi bearing<br>Center distance [mm]: 75   |
| <b>8 030 56 095</b>   | <b>Angle-mill- and drill holder ER 32 AX UT</b>    |   |
|    |  | Weight [kg]: 6.320<br>Notation: 180° reversible<br>Tool drive: Flat (~DIN 1809)<br>Shank size [mm]: 55.00<br>Shank type: BMT<br>Tool adaption: ER 32 A - u-tec<br>Gear ratio [i]: 1:1<br>Torque max [Nm]: 50<br>Rotation max [1/min]: 6000<br>Rotating direction: opposite<br>Coolant: EXT<br>Please note: Combi bearing<br>Center distance [mm]: 65                    |
| <b>8 030 56 096</b>   | <b>Angle-mill- and drill holder ER 32 AX UT IC</b> |   |
|  |  | Weight [kg]: 6.700<br>Notation: 180° reversible<br>Tool drive: Flat (~DIN 1809)<br>Shank size [mm]: 55.00<br>Tool adaption: ER 32 A - u-tec<br>Gear ratio [i]: 1:1<br>Torque max [Nm]: 50<br>Rotation max [1/min]: 6000<br>Rotating direction: opposite<br>Coolant: IC/Ext<br>Pressure max [bar]: 140<br>Please note: Combi bearing<br>Center distance [mm]: 65         |
| <b>8 030 56 107</b>   | <b>Radial drilling and milling head HT 4 IC</b>    |   |
|   |  | Weight [kg]: 7.180<br>Notation: 180° reversible<br>Tool drive: Flat (~DIN 1809)<br>Shank size [mm]: 55.00<br>Shank type: BMT<br>Tool adaption: HT 4<br>Gear ratio [i]: 1:1<br>Torque max [Nm]: 50<br>Rotation max [1/min]: 6000<br>Rotating direction: opposite<br>Coolant: IC/Ext<br>Pressure max [bar]: 140<br>Please note: Combi bearing<br>Center distance [mm]: 75 |

| Part-#              | Name  |                  |
|---------------------|---|------------------|
| <b>8 030 56 121</b> | <b>Radial drilling and milling head HT 4 IC</b> |                  |
|                     | Notation:                                       | 180° reversible  |
|                     | Tool drive:                                     | Flat (~DIN 1809) |
|                     | Shank size [mm]:                                | 55.00            |
|                     | Shank type:                                     | BMT              |
|                     | Tool adaption:                                  | HT 4             |
|                     | Gear ratio [i]:                                 | 1:3              |
|                     | Torque max [Nm]:                                | 12               |
|                     | Rotation max [1/min]:                           | 18000            |
|                     | Rotating direction:                             | same             |
|                     | Coolant:  | IC/Ext           |
|                     | Pressure max [bar]:                             | 140              |
|                     | Please note:                                    | stronger bearing |
|                     | Center distance [mm]:                           | 77               |
| <b>8 030 56 124</b> | <b>Radial drilling and milling head HT 4</b>    |                  |
|                     | Weight [kg]:                                    | 6.300            |
|                     | Notation:                                       | 180° reversible  |
|                     | Tool drive:                                     | Flat (~DIN 1809) |
|                     | Shank size [mm]:                                | 55.00            |
|                     | Shank type:                                     | BMT              |
|                     | Tool adaption:                                  | HT 4             |
|                     | Gear ratio [i]:                                 | 1:3              |
|                     | Torque max [Nm]:                                | 12               |
|                     | Rotation max [1/min]:                           | 18000            |
|                     | Rotating direction:                             | same             |
|                     | Coolant:  | EXT              |
|                     | Please note:                                    | stronger bearing |
|                     | Center distance [mm]:                           | 77               |
| <b>8 030 56 125</b> | <b>Radial drilling and milling head HT 4 IC</b> |                  |
|                     | Weight [kg]:                                    | 6.520            |
|                     | Notation:                                       | 180° reversible  |
|                     | Tool drive:                                     | Flat (~DIN 1809) |
|                     | Shank size [mm]:                                | 55.00            |
|                     | Shank type:                                     | BMT              |
|                     | Tool adaption:                                  | HT 4             |
|                     | Gear ratio [i]:                                 | 1:2              |
|                     | Torque max [Nm]:                                | 16               |
|                     | Rotation max [1/min]:                           | 12000            |
|                     | Rotating direction:                             | same             |
|                     | Coolant:  | IC/Ext           |
|                     | Pressure max [bar]:                             | 140              |
|                     | Please note:                                    | stronger bearing |
|                     | Center distance [mm]:                           | 77               |
| <b>8 030 56 126</b> | <b>Radial drilling and milling head HT 4</b>    |                  |
|                     | Weight [kg]:                                    | 6.340            |
|                     | Notation:                                       | 180° reversible  |
|                     | Tool drive:                                     | Flat (~DIN 1809) |
|                     | Shank size [mm]:                                | 55.00            |
|                     | Shank type:                                     | BMT              |
|                     | Tool adaption:                                  | HT 4             |
|                     | Gear ratio [i]:                                 | 1:2              |
|                     | Torque max [Nm]:                                | 16               |
|                     | Rotation max [1/min]:                           | 12000            |
|                     | Rotating direction:                             | same             |
|                     | Coolant:  | EXT              |

| Part-#  | Name   |  |
|---|--|--|
|   | Please note:                                   | stronger bearing                       |
|   | Center distance [mm]:                          | 77                                     |
| <b>8 030 56 176</b>   | <b>Radial drilling and milling head C 4</b>    |  |
|  | Notation:                                      | 180° reversible                        |
|   | Tool drive:                                    | Flat (~DIN 1809)                       |
|   | Shank size [mm]:                               | 55.00                                  |
|   | Shank type:                                    | BMT                                    |
|   | Tool adaption:                                 | heimatec Capto(TM) C 4                 |
|   | Gear ratio [i]:                                | 1:1                                    |
|   | Torque max [Nm]:                               | 40                                     |
|   | Rotation max [1/min]:                          | 6000                                   |
|   | Rotating direction:                            | opposite                               |
|   | Coolant:                                       | EXT                                    |
|   | Pressure max [bar]:                            | 140                                    |
|   | Please note:                                   | Check applicability; note tool length! |
|   | Center distance [mm]:                          | 65                                     |
| <b>8 030 56 177</b>   | <b>Radial drilling and milling head C 4 IC</b> |  |
|   | Weight [kg]:                                   | 9.780                                  |
|   | Notation:                                      | 180° reversible                        |
|   | Tool drive:                                    | Flat (~DIN 1809)                       |
|   | Shank size [mm]:                               | 55.00                                  |
|   | Shank type:                                    | BMT                                    |
|   | Tool adaption:                                 | heimatec Capto(TM) C 4                 |
|   | Gear ratio [i]:                                | 1:1                                    |
|   | Torque max [Nm]:                               | 40                                     |
|   | Rotation max [1/min]:                          | 6000                                   |
|   | Rotating direction:                            | opposite                               |
|   | Coolant:                                       | IC/Ext                                 |
|   | Pressure max [bar]:                            | 140                                    |
|   | Please note:                                   | Check applicability; note tool length! |
|   | Center distance [mm]:                          | 65                                     |
| <b>8 030 56 214</b>   | <b>Radial drilling and milling head C 4 IC</b> |  |
|   | Notation:                                      | 180° reversible                        |
|   | Tool drive:                                    | Flat (~DIN 1809)                       |
|   | Shank size [mm]:                               | 55.00                                  |
|   | Shank type:                                    | BMT                                    |
|   | Tool adaption:                                 | heimatec Capto(TM) C 4                 |
|   | Gear ratio [i]:                                | 1:1                                    |
|   | Torque max [Nm]:                               | 63                                     |
|   | Rotation max [1/min]:                          | 12000                                  |
|   | Rotating direction:                            | opposite                               |
|   | Coolant:                                       | IC/Ext                                 |
|   | Pressure max [bar]:                            | 140                                    |
|   | Please note:                                   | Check applicability; note tool length! |
|   | Center distance [mm]:                          | 65                                     |
| <b>8 030 56 215</b>   | <b>Radial drilling and milling head C 4</b>    |  |
|   | Notation:                                      | 180° reversible                        |
|   | Tool drive:                                    | Flat (~DIN 1809)                       |
|   | Shank size [mm]:                               | 55.00                                  |
|   | Shank type:                                    | BMT                                    |
|   | Tool adaption:                                 | heimatec Capto(TM) C 4                 |
|   | Gear ratio [i]:                                | 1:1                                    |
|   | Torque max [Nm]:                               | 63                                     |

| Part-# | Name |
|--------|------|
|--------|------|

|                       |  |
|-----------------------|--|
| Rotation max [1/min]: | 12000                                  |
| Rotating direction:   | opposite                               |
| Coolant:              | EXT                                    |
| Please note:          | Check applicability; note tool length! |
| Center distance [mm]: | 65                                     |

**8 030 56 216 Radial drilling and milling head Weldon 20 IC**

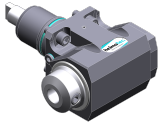

|                       |   |
|-----------------------|---|
| Weight [kg]:          | 7.040                                   |
| Notation:             | 180° reversible                         |
| Tool drive:           | Flat (~DIN 1809)                        |
| Shank size [mm]:      | 55.00                                   |
| Shank type:           | BMT                                     |
| Tool adaption:        | Weldon (DIN 1835 b) 20                  |
| Gear ratio [i]:       | 1:1                                     |
| Torque max [Nm]:      | 50                                      |
| Rotation max [1/min]: | 12000                                   |
| Rotating direction:   | opposite                                |
| Coolant:              | IC/Ext                                  |
| Pressure max [bar]:   | 140                                     |
| Please note:          | stronger bearing; high pressure version |
| Center distance [mm]: | 65                                      |

**8 030 56 235 Radial drilling and milling head ER 32 AX UT**

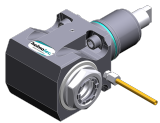

|                       |                  |
|-----------------------|------------------|
| Weight [kg]:          | 6.050            |
| Notation:             | 180° reversible  |
| Tool drive:           | Flat (~DIN 1809) |
| Shank size [mm]:      | 55.00            |
| Shank type:           | BMT              |
| Tool adaption:        | ER 32 A - u-tec  |
| Gear ratio [i]:       | 1:1              |
| Torque max [Nm]:      | 50               |
| Rotation max [1/min]: | 12000            |
| Rotating direction:   | opposite         |
| Coolant:              | EXT              |
| Center distance [mm]: | 65               |

**8 030 56 236 Radial drilling and milling head ER 32 AX UT IC**

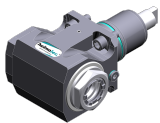

|                       |                  |
|-----------------------|------------------|
| Weight [kg]:          | 5.830            |
| Notation:             | 180° reversible  |
| Tool drive:           | Flat (~DIN 1809) |
| Shank size [mm]:      | 55.00            |
| Shank type:           | BMT              |
| Tool adaption:        | ER 32 A - u-tec  |
| Gear ratio [i]:       | 1:1              |
| Torque max [Nm]:      | 50               |
| Rotation max [1/min]: | 12000            |
| Rotating direction:   | opposite         |
| Coolant:              | IC/Ext           |
| Pressure max [bar]:   | 140              |
| Center distance [mm]: | 65               |

| Part-# | Name |
|--------|------|
|--------|------|

8 030 56 237

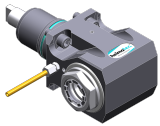

**Radial drilling and milling head ER 32 AX UT**

Weight [kg]: 6.500  
 Notation: 180° reversible  
 Tool drive: Flat (~DIN 1809)  
 Shank size [mm]: 55.00  
 Shank type: BMT  
 Tool adaption: ER 32 A - u-tec  
 Gear ratio [i]: 1:1  
 Torque max [Nm]: 50  
 Rotation max [1/min]: 12000  
 Rotating direction: opposite  
 Coolant: EXT  
 Center distance [mm]: 75

8 030 56 238



**Radial drilling and milling head ER 32 AX UT IC**

Weight [kg]: 7.200  
 Notation: 180° reversible  
 Tool drive: Flat (~DIN 1809)  
 Shank size [mm]: 55.00  
 Shank type: BMT  
 Tool adaption: ER 32 A - u-tec  
 Gear ratio [i]: 1:1  
 Torque max [Nm]: 50  
 Rotation max [1/min]: 12000  
 Rotating direction: opposite  
 Coolant: IC/Ext  
 Pressure max [bar]: 140  
 Center distance [mm]: 75

8 030 56 239

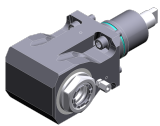

**Radial drilling and milling head ER 32 AX UT**

Weight [kg]: 7.500  
 Notation: 180° reversible  
 Tool drive: Flat (~DIN 1809)  
 Shank size [mm]: 55.00  
 Shank type: BMT  
 Tool adaption: ER 32 A - u-tec  
 Gear ratio [i]: 1:1  
 Torque max [Nm]: 50  
 Rotation max [1/min]: 12000  
 Rotating direction: opposite  
 Coolant: EXT  
 Please note: Check applicability!  
 Center distance [mm]: 95

8 030 56 240

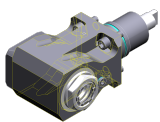

**Radial drilling and milling head ER 32 AX UT IC**

Weight [kg]: 7.960  
 Notation: 180° reversible  
 Tool drive: Flat (~DIN 1809)  
 Shank size [mm]: 55.00  
 Shank type: BMT  
 Tool adaption: ER 32 A - u-tec  
 Gear ratio [i]: 1:1  
 Torque max [Nm]: 50  
 Rotation max [1/min]: 12000  
 Rotating direction: opposite  
 Coolant: IC/Ext

# Nakamura

## Super NTJ-unterer Revolver

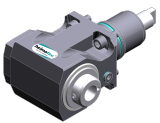
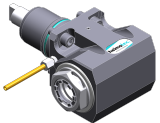
| Part-#  | Name   |                      |
|---|--|----------------------|
|   | Pressure max [bar]:                                    | 140                  |
|   | Please note:   | Check applicability! |
|   | Center distance [mm]:                                  | 95                   |
| <b>8 030 56 249</b>   | <b>Radial drilling and milling head HT 4 IC</b>        |                      |
|   | Weight [kg]:   | 6.580                |
|   | Notation:  | 180° reversible      |
|   | Tool drive:  | Flat (~DIN 1809)     |
|   | Shank size [mm]:                                       | 55.00                |
|   | Shank type:  | BMT                  |
|   | Tool adaption:   | HT 4                 |
|   | Gear ratio [i]:  | 1:1                  |
|   | Torque max [Nm]:                                       | 50                   |
|   | Rotation max [1/min]:                                  | 12000                |
|   | Rotating direction:                                    | opposite             |
|   | Coolant:   | IC/Ext               |
|   | Pressure max [bar]:                                    | 140                  |
|   | Center distance [mm]:                                  | 65                   |
| <b>8 030 56 257</b>   | <b>Radial drilling and milling head HT 4 IC</b>        |                      |
|   | Notation:  | 180° reversible      |
|   | Tool drive:  | Flat (~DIN 1809)     |
|   | Shank size [mm]:                                       | 55.00                |
|   | Shank type:  | BMT                  |
|   | Tool adaption:   | HT 4                 |
|   | Gear ratio [i]:  | 1:1                  |
|   | Torque max [Nm]:                                       | 50                   |
|   | Rotation max [1/min]:                                  | 12000                |
|   | Rotating direction:                                    | opposite             |
|   | Coolant:   | IC/Ext               |
|   | Pressure max [bar]:                                    | 140                  |
|   | Center distance [mm]:                                  | 75                   |
| <b>8 030 56 271</b>   | <b>Radial drilling and milling head ER 32 AX UT</b>    |                      |
|  | Weight [kg]:   | 6.380                |
|   | Notation:  | 180° reversible      |
|   | Tool drive:  | Flat (~DIN 1809)     |
|   | Shank size [mm]:                                       | 55.00                |
|   | Shank type:  | BMT                  |
|   | Tool adaption:   | ER 32 A - u-tec      |
|   | Gear ratio [i]:  | 1:1                  |
|   | Torque max [Nm]:                                       | 50                   |
|   | Rotation max [1/min]:                                  | 12000                |
|   | Rotating direction:                                    | opposite             |
|   | Coolant:   | EXT                  |
|   | Pressure max [bar]:                                    | 140                  |
|   | Please note:   | stronger bearing     |
|   | Center distance [mm]:                                  | 65                   |
| <b>8 030 56 275</b>   | <b>Radial drilling and milling head ER 32 AX UT IC</b> |                      |
|  | Weight [kg]:   | 6.700                |
|   | Notation:  | 180° reversible      |
|   | Tool drive:  | Flat (~DIN 1809)     |
|   | Shank size [mm]:                                       | 55.00                |
|   | Shank type:  | BMT                  |
|   | Tool adaption:   | ER 32 A - u-tec      |
|   | Gear ratio [i]:  | 1:1                  |

| Part-#              | Name   |                        |
|---------------------|--|------------------------|
|                     | Torque max [Nm]:                                     | 50                     |
|                     | Rotation max [1/min]:                                | 12000                  |
|                     | Rotating direction:                                  | opposite               |
|                     | Coolant:   | IC/Ext                 |
|                     | Pressure max [bar]:                                  | 140                    |
|                     | Please note:   | stronger bearing       |
|                     | Center distance [mm]:                                | 65                     |
| <b>8 030 57 044</b> | <b>Radial drilling and milling head Weldon 25 IC</b> |                        |
|                     | Weight [kg]:   | 7.150                  |
|                     | Notation:  | 180° reversible        |
|                     | Tool drive:  | Flat (~DIN 1809)       |
|                     | Shank size [mm]:                                     | 55.00                  |
|                     | Shank type:  | BMT                    |
|                     | Tool adaption:                                       | Weldon (DIN 1835 b) 25 |
|                     | Gear ratio [i]:                                      | 1:1                    |
|                     | Torque max [Nm]:                                     | 50                     |
|                     | Rotation max [1/min]:                                | 6000                   |
|                     | Rotating direction:                                  | opposite               |
|                     | Coolant:   | IC/Ext                 |
|                     | Pressure max [bar]:                                  | 140                    |
|                     | Please note:   | Combi bearing          |
|                     | Center distance [mm]:                                | 65                     |
| <b>8 030 57 120</b> | <b>Radial drilling and milling head ER 40 AX UT</b>  |                        |
|                     | Notation:  | 180° reversible        |
|                     | Tool drive:  | Flat (~DIN 1809)       |
|                     | Shank size [mm]:                                     | 55.00                  |
|                     | Shank type:  | BMT                    |
|                     | Tool adaption:                                       | ER 40 A - u-tec        |
|                     | Gear ratio [i]:                                      | 1:1                    |
|                     | Torque max [Nm]:                                     | 50                     |
|                     | Rotation max [1/min]:                                | 6000                   |
|                     | Rotating direction:                                  | opposite               |
|                     | Coolant:   | EXT                    |
|                     | Please note:   | stronger bearing       |
|                     | Center distance [mm]:                                | 65                     |
| <b>8 031 54 014</b> | <b>Radial milling head universal arbor 16</b>        |                        |
|                     | Weight [kg]:   | 6.500                  |
|                     | Notation:  | 180° reversible        |
|                     | Tool drive:  | Flat (~DIN 1809)       |
|                     | Shank size [mm]:                                     | 55.00                  |
|                     | Shank type:  | BMT                    |
|                     | Tool adaption:                                       | Universal arbor 16     |
|                     | Gear ratio [i]:                                      | 1:1                    |
|                     | Torque max [Nm]:                                     | 50                     |
|                     | Rotation max [1/min]:                                | 6000                   |
|                     | Rotating direction:                                  | opposite               |
|                     | Coolant:   | EXT                    |
|                     | Please note:   | Combi bearing          |
|                     | Center distance [mm]:                                | 65                     |

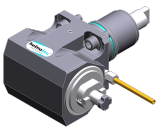

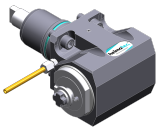
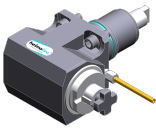
| Part-#  | Name                  |   |                    |
|---|-----------------------|---|--------------------|
|  | <b>8 031 54 015</b>   | <b>Radial polygon head arbor 16</b>           |                    |
|   |                       | Weight [kg]:                                  | 6.650              |
|   |                       | Notation:                                     | 180° reversible    |
|   |                       | Tool drive:                                   | Flat (~DIN 1809)   |
|   |                       | Shank size [mm]:                              | 55.00              |
|   |                       | Shank type:                                   | BMT                |
|   |                       | Tool adaption:                                | Polygon arbor 16   |
|   |                       | Gear ratio [i]:                               | 1:1                |
|   |                       | Torque max [Nm]:                              | 50                 |
|   |                       | Rotation max [1/min]:                         | 6000               |
|   |                       | Rotating direction:                           | opposite           |
|   |                       | Coolant:                                      | EXT                |
|   |                       | Please note:                                  | Combi bearing      |
|   | Center distance [mm]: | 65  |                    |
|  | <b>8 031 56 010</b>   | <b>Radial polygon head arbor 27</b>           |                    |
|   |                       | Notation:                                     | 180° reversible    |
|   |                       | Tool drive:                                   | Flat (~DIN 1809)   |
|   |                       | Shank size [mm]:                              | 55.00              |
|   |                       | Shank type:                                   | BMT                |
|   |                       | Tool adaption:                                | Polygon arbor 27   |
|   |                       | Gear ratio [i]:                               | 1:1                |
|   |                       | Torque max [Nm]:                              | 50                 |
|   |                       | Rotation max [1/min]:                         | 6000               |
|   |                       | Rotating direction:                           | opposite           |
|   |                       | Coolant:                                      | EXT                |
|   |                       | Please note:                                  | Combi bearing      |
|   |                       | Center distance [mm]:                         | 65                 |
|   | <b>8 031 56 012</b>   | <b>Radial milling head universal arbor 27</b> |                    |
|   |                       | Weight [kg]:                                  | 6.560              |
|   |                       | Notation:                                     | 180° reversible    |
|   |                       | Tool drive:                                   | Flat (~DIN 1809)   |
|   |                       | Shank size [mm]:                              | 55.00              |
|   |                       | Shank type:                                   | BMT                |
|   |                       | Tool adaption:                                | Universal arbor 27 |
|   |                       | Gear ratio [i]:                               | 1:1                |
|   |                       | Torque max [Nm]:                              | 50                 |
|   |                       | Rotation max [1/min]:                         | 6000               |
|   |                       | Rotating direction:                           | opposite           |
|   |                       | Coolant:                                      | EXT                |
|   |                       | Please note:                                  | Combi bearing      |
|   | Center distance [mm]: | 65  |                    |
|   | <b>8 031 56 022</b>   | <b>Radial milling head universal arbor 27</b> |                    |
|   |                       | Notation:                                     | 180° reversible    |
|   |                       | Tool drive:                                   | Flat (~DIN 1809)   |
|   |                       | Shank size [mm]:                              | 55.00              |
|   |                       | Shank type:                                   | BMT                |
|   |                       | Tool adaption:                                | Universal arbor 27 |
|   |                       | Gear ratio [i]:                               | 2:1                |
|   |                       | Torque max [Nm]:                              | 63                 |
|   |                       | Rotation max [1/min]:                         | 3000               |
|   |                       | Rotating direction:                           | opposite           |
|   |                       | Coolant:                                      | EXT                |
|   |                       | Please note:                                  | Combi bearing      |
|   |                       | Center distance [mm]:                         | 65                 |

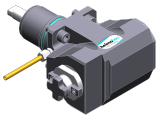
| Part-#  | Name                  |  |                         |
|---|-----------------------|--|-------------------------|
|  | <b>8 031 56 026</b>   | <b>Radial milling head arbor 27</b>                    |                         |
|   |                       | Notation:  | 180° reversible         |
|   |                       | Tool drive:  | Flat (~DIN 1809)        |
|   |                       | Shank size [mm]:                                       | 55.00                   |
|   |                       | Shank type:  | BMT                     |
|   |                       | Tool adaption:   | Arbor 27                |
|   |                       | Gear ratio [i]:  | 2:1                     |
|   |                       | Torque max [Nm]:                                       | 63                      |
|   |                       | Rotation max [1/min]:                                  | 3000                    |
|   |                       | Rotating direction:                                    | opposite                |
|   |                       | Coolant:   | EXT                     |
|   |                       | Please note:   | Combi bearing           |
|   |                       | Center distance [mm]:                                  | 65                      |
|   | <b>8 033 56 018</b>   | <b>Radial drilling and milling head HT 4</b>           |                         |
|   |                       | Weight [kg]:   | 8.200                   |
|   |                       | Notation:  | offset; 180° reversible |
|   |                       | Tool drive:  | Flat (~DIN 1809)        |
|   |                       | Shank size [mm]:                                       | 55.00                   |
|   |                       | Shank type:  | BMT                     |
|   |                       | Tool adaption:   | HT 4                    |
|   |                       | Gear ratio [i]:  | 1:1                     |
|   |                       | Torque max [Nm]:                                       | 50                      |
|   |                       | Rotation max [1/min]:                                  | 6000                    |
|   |                       | Rotating direction:                                    | same                    |
|   |                       | Coolant:   | EXT                     |
|   |                       | Please note:   | Combi bearing           |
|   | Center distance [mm]: | 75   |                         |
|   | <b>8 033 56 019</b>   | <b>Radial drilling and milling head HT 4 IC</b>        |                         |
|   |                       | Weight [kg]:   | 8.700                   |
|   |                       | Notation:  | offset; 180° reversible |
|   |                       | Tool drive:  | Flat (~DIN 1809)        |
|   |                       | Shank size [mm]:                                       | 55.00                   |
|   |                       | Shank type:  | BMT                     |
|   |                       | Tool adaption:   | HT 4                    |
|   |                       | Gear ratio [i]:  | 1:1                     |
|   |                       | Torque max [Nm]:                                       | 50                      |
|   |                       | Rotation max [1/min]:                                  | 6000                    |
|   |                       | Rotating direction:                                    | same                    |
|   |                       | Coolant:   | IC/Ext                  |
|   |                       | Pressure max [bar]:                                    | 140                     |
|   | Please note:          | Combi bearing  |                         |
|   | Center distance [mm]: | 75   |                         |
|   | <b>8 033 56 020</b>   | <b>Radial drilling and milling head ER 32 AX UT IC</b> |                         |
|   |                       | Weight [kg]:   | 8.670                   |
|   |                       | Notation:  | offset; 180° reversible |
|   |                       | Tool drive:  | Flat (~DIN 1809)        |
|   |                       | Shank size [mm]:                                       | 55.00                   |
|   |                       | Shank type:  | BMT                     |
|   |                       | Tool adaption:   | ER 32 A - u-tec         |
|   |                       | Gear ratio [i]:  | 1:1                     |
|   |                       | Torque max [Nm]:                                       | 50                      |
|   |                       | Rotation max [1/min]:                                  | 6000                    |
|   |                       | Rotating direction:                                    | same                    |
|   |                       | Coolant:   | IC/Ext                  |
|   |                       | Pressure max [bar]:                                    | 140                     |

# Nakamura

## Super NTJ-unterer Revolver

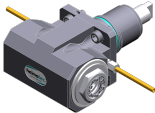
| Part-#  | Name   |                            |
|---|--|----------------------------|
|   | Please note:   | Combi bearing              |
|   | Center distance [mm]:                                  | 75                         |
| <b>8 039 54 029</b>   | <b>Radial milling head arbor 16</b>                    |                            |
|   | Weight [kg]:   | 9.600                      |
|   | Notation:  | offset; 180° reversible    |
|   | Version:   | Special; ±45° turnable     |
|   | Tool drive:  | Flat (~DIN 1809)           |
|   | Shank size [mm]:                                       | 55.00                      |
|   | Shank type:  | BMT                        |
|   | Tool adaption:   | Arbor 16                   |
|   | Gear ratio [i]:  | 1:1                        |
|   | Torque max [Nm]:                                       | 50                         |
|   | Rotation max [1/min]:                                  | 6000                       |
|   | Rotating direction:                                    | same                       |
|   | Coolant:   | EXT                        |
|   | Please note:   | stronger bearing           |
|   | Center distance [mm]:                                  | 91                         |
| <b>8 039 54 035</b>   | <b>Radial drilling and milling head ER 16 AX UT IC</b> |                            |
|   | Weight [kg]:   | 4.980                      |
|   | Notation:  | 180° reversible; 35° angle |
|   | Tool drive:  | Flat (~DIN 1809)           |
|   | Shank size [mm]:                                       | 55.00                      |
|   | Shank type:  | BMT                        |
|   | Tool adaption:   | ER 16 A - u-tec            |
|   | Gear ratio [i]:  | 1:1                        |
|   | Torque max [Nm]:                                       | 40                         |
|   | Rotation max [1/min]:                                  | 6000                       |
|   | Rotating direction:                                    | opposite                   |
|   | Coolant:   | IC/Ext                     |
|   | Pressure max [bar]:                                    | 140                        |
| <b>8 039 55 003</b>   | <b>Radial drilling and milling head ER 25</b>          |                            |
|   | Weight [kg]:   | 5.330                      |
|   | Version:   | double spindle             |
|   | Tool drive:  | Flat (~DIN 1809)           |
|   | Shank size [mm]:                                       | 55.00                      |
|   | Shank type:  | BMT                        |
|   | Tool adaption:   | ER 25                      |
|   | Gear ratio [i]:  | 1:1                        |
|   | Torque max [Nm]:                                       | 25                         |
|   | Rotation max [1/min]:                                  | 6000                       |
|   | Rotating direction:                                    | same/opposite              |
|   | Coolant:   | EXT                        |
|   | Center distance [mm]:                                  | 55                         |
| <b>8 039 55 042</b>   | <b>Radial drilling and milling head ER 25 AX UT</b>    |                            |
|  | Weight [kg]:   | 6.480                      |
|   | Notation:  | 180° reversible            |
|   | Employment for:  | Main- and sub spindle      |
|   | Version:   | double spindle             |
|   | Tool drive:  | Flat (~DIN 1809)           |
|   | Shank size [mm]:                                       | 55.00                      |
|   | Shank type:  | BMT                        |
|   | Tool adaption:   | ER 25 A - u-tec            |
|   | Gear ratio [i]:  | 1:1                        |

# Nakamura

## Super NTJ-unterer Revolver

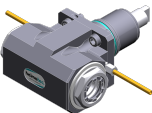
| Part-#  | Name  |                                       |
|---|---|---------------------------------------|
|   | Torque max [Nm]:                                    | 50                                    |
|   | Rotation max [1/min]:                               | 12000                                 |
|   | Rotating direction:                                 | same/opposite                         |
|   | Coolant:  | EXT                                   |
|   | Please note:  | stronger bearing                      |
|   | Center distance [mm]:                               | 65                                    |
| <b>8 039 56 009</b>   | <b>Radial drilling and milling head HT 4</b>        |                                       |
|   | Weight [kg]:  | 6.600                                 |
|   | Notation:   | 180° reversible                       |
|   | Employment for:                                     | Main- and sub spindle                 |
|   | Version:  | double spindle                        |
|   | Tool drive:   | Flat (~DIN 1809)                      |
|   | Shank size [mm]:                                    | 55.00                                 |
|   | Shank type:   | BMT                                   |
|   | Tool adaption:                                      | HT 4                                  |
|   | Gear ratio [i]:                                     | 1:1                                   |
|   | Torque max [Nm]:                                    | 50                                    |
|   | Rotation max [1/min]:                               | 12000                                 |
|   | Rotating direction:                                 | same/opposite                         |
|   | Coolant:  | EXT                                   |
|   | Please note:  | stronger bearing                      |
|   | Center distance [mm]:                               | 65                                    |
| <b>8 039 56 016</b>   | <b>Radial drilling and milling head ER 32 AX UT</b> |                                       |
|  | Weight [kg]:  | 6.300                                 |
|   | Notation:   | 180° reversible                       |
|   | Employment for:                                     | Main- and sub spindle                 |
|   | Version:  | double spindle                        |
|   | Tool drive:   | Flat (~DIN 1809)                      |
|   | Shank size [mm]:                                    | 55.00                                 |
|   | Shank type:   | BMT                                   |
|   | Tool adaption:                                      | ER 32 A - u-tec                       |
|   | Gear ratio [i]:                                     | 1:1                                   |
|   | Torque max [Nm]:                                    | 50                                    |
|   | Rotation max [1/min]:                               | 12000                                 |
|   | Rotating direction:                                 | same/opposite                         |
|   | Coolant:  | EXT                                   |
|   | Please note:  | stronger bearing                      |
|   | Center distance [mm]:                               | 65                                    |
| <b>8 039 56 032</b>   | <b>Radial drilling and milling head C 4</b>         |                                       |
|   | Notation:   | 180° reversible                       |
|   | Employment for:                                     | Main- and sub spindle                 |
|   | Version:  | double spindle                        |
|   | Tool drive:   | Flat (~DIN 1809)                      |
|   | Shank size [mm]:                                    | 55.00                                 |
|   | Shank type:   | BMT                                   |
|   | Tool adaption:                                      | heimatec Capto(TM) C 4                |
|   | Gear ratio [i]:                                     | 1:1                                   |
|   | Torque max [Nm]:                                    | 40                                    |
|   | Rotation max [1/min]:                               | 6000                                  |
|   | Rotating direction:                                 | same/opposite                         |
|   | Coolant:  | EXT                                   |
|   | Please note:  | Check applicability; note tool length |
|   | Center distance [mm]:                               | 65                                    |

| Part-#              | Name   |                         |
|---------------------|--|-------------------------|
| <b>8 039 56 038</b> | <b>Radial drilling and milling head ER 32 AX UT IC</b> |                         |
|                     | Notation:  | offset; 180° reversible |
|                     | Version:   | ± 45° turnable          |
|                     | Tool drive:  | Flat (~DIN 1809)        |
|                     | Shank size [mm]:                                       | 55.00                   |
|                     | Shank type:  | BMT                     |
|                     | Tool adaption:   | ER 32 A - u-tec         |
|                     | Gear ratio [i]:  | 1:1                     |
|                     | Torque max [Nm]:                                       | 50                      |
|                     | Rotation max [1/min]:                                  | 6000                    |
|                     | Rotating direction:                                    | same                    |
|                     | Coolant:   | IC/Ext                  |
|                     | Pressure max [bar]:                                    | 140                     |
|                     | Please note:   | stronger bearing        |
|                     | Center distance [mm]:                                  | 91                      |
| <b>8 039 56 040</b> | <b>Radial drilling and milling head ER 32 AX UT</b>    |                         |
|                     | Weight [kg]:   | 9.360                   |
|                     | Notation:  | offset; 180° reversible |
|                     | Version:   | ± 45° turnable          |
|                     | Tool drive:  | Flat (~DIN 1809)        |
|                     | Shank size [mm]:                                       | 55.00                   |
|                     | Shank type:  | BMT                     |
|                     | Tool adaption:   | ER 32 A - u-tec         |
|                     | Gear ratio [i]:  | 1:1                     |
|                     | Torque max [Nm]:                                       | 50                      |
|                     | Rotation max [1/min]:                                  | 6000                    |
|                     | Rotating direction:                                    | same                    |
|                     | Coolant:   | EXT                     |
|                     | Please note:   | stronger bearing        |
|                     | Center distance [mm]:                                  | 91                      |
| <b>8 039 56 041</b> | <b>Radial drilling and milling head hydro 20</b>       |                         |
|                     | Weight [kg]:   | 9.680                   |
|                     | Notation:  | offset; 180° reversible |
|                     | Version:   | ± 45° turnable          |
|                     | Tool drive:  | Flat (~DIN 1809)        |
|                     | Shank size [mm]:                                       | 55.00                   |
|                     | Shank type:  | BMT                     |
|                     | Tool adaption:   | Hydro clamp Ø 20        |
|                     | Gear ratio [i]:  | 1:1                     |
|                     | Torque max [Nm]:                                       | 50                      |
|                     | Rotation max [1/min]:                                  | 6000                    |
|                     | Rotating direction:                                    | same                    |
|                     | Coolant:   | EXT                     |
|                     | Please note:   | stronger bearing        |
|                     | Center distance [mm]:                                  | 91                      |
| <b>8 040 53 000</b> | <b>Universal head ± 90° adjustable ER 11 AX</b>        |                         |
|                     | Weight [kg]:   | 3.150                   |
|                     | Tool drive:  | Flat (~DIN 1809)        |
|                     | Shank size [mm]:                                       | 55.00                   |
|                     | Shank type:  | BMT                     |
|                     | Tool adaption:   | ER 11 A                 |
|                     | Gear ratio [i]:  | 1:1                     |
|                     | Torque max [Nm]:                                       | 10                      |
|                     | Rotation max [1/min]:                                  | 5000                    |
|                     | Rotating direction:                                    | same                    |

Nakamura  
Super NTJ-unterer Revolver



| Part-#              | Name  |                            |
|---------------------|---|----------------------------|
|                     | Coolant:  | EXT                        |
|                     | Center distance [mm]:                           | 57                         |
| <b>8 040 53 001</b> | <b>Universal head ± 90° adjustable ER 11 AX</b> |                            |
|                     | Weight [kg]:                                    | 2.900                      |
|                     | Tool drive:                                     | Flat (~DIN 1809)           |
|                     | Shank size [mm]:                                | 55.00                      |
|                     | Shank type:                                     | BMT                        |
|                     | Tool adaption:                                  | ER 11 A                    |
|                     | Gear ratio [i]:                                 | 1:1                        |
|                     | Torque max [Nm]:                                | 10                         |
|                     | Rotation max [1/min]:                           | 6000                       |
|                     | Rotating direction:                             | same                       |
|                     | Coolant:  | EXT                        |
|                     | Center distance [mm]:                           | 57                         |
| <b>8 040 53 002</b> | <b>Universal head ± 90° adjustable ER 11 AX</b> |                            |
|                     | Weight [kg]:                                    | 2.880                      |
|                     | Tool drive:                                     | Flat (~DIN 1809)           |
|                     | Shank size [mm]:                                | 55.00                      |
|                     | Shank type:                                     | BMT                        |
|                     | Tool adaption:                                  | ER 11 A                    |
|                     | Gear ratio [i]:                                 | 1:1                        |
|                     | Torque max [Nm]:                                | 10                         |
|                     | Rotation max [1/min]:                           | 6000                       |
|                     | Rotating direction:                             | same                       |
|                     | Coolant:  | EXT                        |
| <b>8 040 53 003</b> | <b>Universal head ± 90° adjustable ER 11 AX</b> |                            |
|                     | Weight [kg]:                                    | 3.160                      |
|                     | Tool drive:                                     | Flat (~DIN 1809)           |
|                     | Shank size [mm]:                                | 55.00                      |
|                     | Shank type:                                     | BMT                        |
|                     | Tool adaption:                                  | ER 11 A                    |
|                     | Gear ratio [i]:                                 | 1:1                        |
|                     | Torque max [Nm]:                                | 10                         |
|                     | Rotation max [1/min]:                           | 6000                       |
|                     | Rotating direction:                             | same                       |
|                     | Coolant:  | EXT                        |
|                     | Center distance [mm]:                           | 57                         |
| <b>8 040 54 012</b> | <b>Universal head ± 90° adjustable HT 2</b>     |                            |
|                     | Version:  | 75° position can be pinned |
|                     | Tool drive:                                     | Flat (~DIN 1809)           |
|                     | Shank size [mm]:                                | 55.00                      |
|                     | Shank type:                                     | BMT                        |
|                     | Tool adaption:                                  | HT 2                       |
|                     | Gear ratio [i]:                                 | 1:1                        |
|                     | Torque max [Nm]:                                | 10                         |
|                     | Rotation max [1/min]:                           | 6000                       |
|                     | Rotating direction:                             | same                       |
|                     | Coolant:  | EXT                        |
|                     | Center distance [mm]:                           | 57                         |

# Nakamura Super NTJ-unterer Revolver

| Part-#   | Name   |                         |
|--|--|-------------------------|
| <b>8 050 54 005</b>  | <b>Multispindle drilling head ER 16 AX UT</b>    |                         |
|  | Weight [kg]:                                     | 6.100                   |
|  | Notation:  | offset                  |
|  | Version:   | 2-spindles              |
|  | Tool drive:                                      | Flat (~DIN 1809)        |
|  | Shank size [mm]:                                 | 55.00                   |
|  | Shank type:                                      | BMT                     |
|  | Tool adaption:                                   | ER 16 A - u-tec         |
|  | Gear ratio [i]:                                  | 1:2                     |
|  | Torque max [Nm]:                                 | 16                      |
|  | Rotation max [1/min]:                            | 12000                   |
|  | Rotating direction:                              | same                    |
|  | Coolant:   | EXT                     |
|  | Offset [mm]:                                     | 56                      |
| <b>8 050 54 008</b>  | <b>Multispindle drilling head ER 16 AX UT</b>    |                         |
|  | Weight [kg]:                                     | 5.700                   |
|  | Notation:  | offset                  |
|  | Version:   | 2-spindles              |
|  | Tool drive:                                      | Flat (~DIN 1809)        |
|  | Shank size [mm]:                                 | 55.00                   |
|  | Tool adaption:                                   | ER 16 A - u-tec         |
|  | Gear ratio [i]:                                  | 1:1                     |
|  | Torque max [Nm]:                                 | 25                      |
|  | Rotation max [1/min]:                            | 6000                    |
|  | Rotating direction:                              | same                    |
|  | Coolant:   | EXT                     |
| <b>8 050 54 014</b>  | <b>Multispindle drilling head ER 20 AX UT IC</b> |                         |
|  | Weight [kg]:                                     | 5.920                   |
|  | Notation:  | offset                  |
|  | Version:   | 2-spindles              |
|  | Tool drive:                                      | Flat (~DIN 1809)        |
|  | Shank size [mm]:                                 | 55.00                   |
|  | Shank type:                                      | BMT                     |
|  | Tool adaption:                                   | ER 20 A - u-tec         |
|  | Gear ratio [i]:                                  | 1:1                     |
|  | Torque max [Nm]:                                 | 25                      |
|  | Rotation max [1/min]:                            | 6000                    |
|  | Rotating direction:                              | same                    |
|  | Coolant:   | IC/Ext                  |
|  | Pressure max [bar]:                              | 140                     |
|  | Offset [mm]:                                     | 58                      |
| <b>8 050 54 021</b>  | <b>Multispindle drilling head ER 16 AX UT IC</b> |                         |
|  | Weight [kg]:                                     | 6.110                   |
|  | Notation:  | offset; 180° reversible |
|  | Version:   | 2-spindles              |
|  | Tool drive:                                      | Flat (~DIN 1809)        |
|  | Shank size [mm]:                                 | 55.00                   |
|  | Shank type:                                      | BMT                     |
|  | Tool adaption:                                   | ER 16 A - u-tec         |
|  | Gear ratio [i]:                                  | 1:2                     |
|  | Torque max [Nm]:                                 | 16                      |
|  | Rotation max [1/min]:                            | 12000                   |
|  | Rotating direction:                              | same                    |
|  | Coolant:   | IC/Ext                  |
|  | Pressure max [bar]:                              | 25                      |

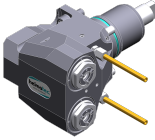
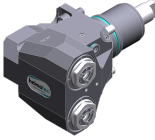
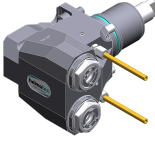
| Part-#              | Name   |  |
|---------------------|--|--|
|                     | Offset [mm]:                                     | 56   |
| <b>8 050 54 036</b> | <b>Multispindle drilling head ER 16 AX UT IC</b> |  |
|                     | Weight [kg]:                                     | 6.040  |
|                     | Notation:  | offset; 180° reversible                        |
|                     | Version:   | 3-spindles                                     |
|                     | Tool drive:                                      | Flat (~DIN 1809)                               |
|                     | Shank size [mm]:                                 | 55.00  |
|                     | Shank type:                                      | BMT  |
|                     | Tool adaption:                                   | ER 16 A - u-tec                                |
|                     | Gear ratio [i]:                                  | 1:1  |
|                     | Torque max [Nm]:                                 | 25   |
|                     | Rotation max [1/min]:                            | 6000   |
|                     | Rotating direction:                              | same   |
|                     | Coolant:   | IC/Ext   |
|                     | Pressure max [bar]:                              | 140  |
|                     | Please note:                                     | 2x ER 16 A offset, 1x centered, IC only in 2 x |
|                     | Offset [mm]:                                     | 56   |
| <b>8 050 54 037</b> | <b>Multispindle drilling head ER 16 AX UT</b>    |  |
|                     | Weight [kg]:                                     | 6.900  |
|                     | Notation:  | offset; 180° reversible                        |
|                     | Employment for:                                  | Main- and sub spindle                          |
|                     | Tool drive:                                      | Flat (~DIN 1809)                               |
|                     | Shank size [mm]:                                 | 55.00  |
|                     | Shank type:                                      | BMT  |
|                     | Tool adaption:                                   | ER 16 A - u-tec                                |
|                     | Gear ratio [i]:                                  | 1:1  |
|                     | Torque max [Nm]:                                 | 16/Sp.   |
|                     | Rotation max [1/min]:                            | 6000   |
|                     | Rotating direction:                              | opposite                                       |
|                     | Coolant:   | no   |
|                     | Please note:                                     | stronger bearing                               |
|                     | Offset [mm]:                                     | +38,1/-38,1                                    |
| <b>8 050 54 038</b> | <b>Multispindle drilling head ER 16 AX UT</b>    |  |
|                     | Weight [kg]:                                     | 6.870  |
|                     | Notation:  | offset; 180° reversible                        |
|                     | Employment for:                                  | Main- and sub spindle                          |
|                     | Tool drive:                                      | Flat (~DIN 1809)                               |
|                     | Shank size [mm]:                                 | 55.00  |
|                     | Shank type:                                      | BMT  |
|                     | Tool adaption:                                   | ER 16 A - u-tec                                |
|                     | Gear ratio [i]:                                  | 1:1  |
|                     | Torque max [Nm]:                                 | 16/Sp.   |
|                     | Rotation max [1/min]:                            | 6000   |
|                     | Rotating direction:                              | opposite                                       |
|                     | Coolant:   | EXT  |
|                     | Please note:                                     | stronger bearing                               |
|                     | Offset [mm]:                                     | +38,1/-38,1                                    |
| <b>8 050 56 006</b> | <b>Multispindle drilling head C 4 IC</b>         |  |
|                     | Notation:  | 180° reversible                                |
|                     | Employment for:                                  | Main- and sub spindle                          |
|                     | Version:   | 2-spindles                                     |
|                     | Tool drive:                                      | Flat (~DIN 1809)                               |
|                     | Shank size [mm]:                                 | 55.00  |
|                     | Shank type:                                      | BMT  |

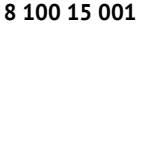
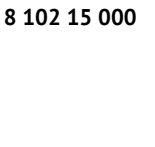
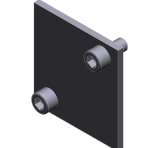
| Part-#  | Name   |  |
|---|--|--|
|   | Tool adaption:<br>Gear ratio [i]:<br>Torque max [Nm]:<br>Rotation max [1/min]:<br>Rotating direction:<br>Coolant:<br>Pressure max [bar]:<br>Please note:<br>Offset [mm]:   | heimatec Capto(TM) C 4<br>1:1<br>50/Sp.<br>6000<br>opposite<br>IC/Ext<br>140<br>Check applicability; tool length check !<br>62               |
| <b>8 053 54 045</b>   | <b>Multispindle radial head ER 16 AX UT</b>  |  |
|    | Weight [kg]:<br>Notation:<br>Version:<br>Tool drive:<br>Shank size [mm]:<br>Shank type:<br>Tool adaption:<br>Gear ratio [i]:<br>Torque max [Nm]:<br>Rotation max [1/min]:<br>Rotating direction:<br>Coolant:<br>Center distance [mm]:        | 6.850<br>180° reversible<br>2-spindles<br>Flat (~DIN 1809)<br>55.00<br>BMT<br>ER 16 A - u-tec<br>1:1<br>32/Sp<br>12000<br>same<br>EXT<br>75  |
| <b>8 053 54 046</b>   | <b>Multispindle radial head ER 16 AX UTIK</b>  |  |
|  | Notation:<br>Version:<br>Tool drive:<br>Shank size [mm]:<br>Shank type:<br>Tool adaption:<br>Gear ratio [i]:<br>Torque max [Nm]:<br>Rotation max [1/min]:<br>Rotating direction:<br>Coolant:<br>Pressure max [bar]:<br>Center distance [mm]: | 180° reversible<br>2-spindles<br>Flat (~DIN 1809)<br>55.00<br>BMT<br>ER 16 A - u-tec<br>1:1<br>32/Sp<br>12000<br>same<br>IC/Ext<br>140<br>75 |
| <b>8 053 54 047</b>   | <b>Multispindle radial head ER 20 AX UT</b>  |  |
|  | Notation:<br>Version:<br>Tool drive:<br>Shank size [mm]:<br>Shank type:<br>Tool adaption:<br>Gear ratio [i]:<br>Torque max [Nm]:<br>Rotation max [1/min]:<br>Rotating direction:<br>Coolant:<br>Center distance [mm]:                        | 180° reversible<br>2-spindles<br>Flat (~DIN 1809)<br>55.00<br>BMT<br>ER 20 A - u-tec<br>1:1<br>32/Sp<br>12000<br>same<br>EXT<br>75           |

| Part-#              | Name  |  |
|---------------------|---|--|
| <b>8 053 54 048</b> | <b>Multispindle radial head ER 20 AX UTIK</b> |   |
|                     |   | <p>Notation: 180° reversible<br/>           Version: 2-spindles<br/>           Tool drive: Flat (~DIN 1809)<br/>           Shank size [mm]: 55.00<br/>           Shank type: BMT<br/>           Tool adaption: ER 20 A - u-tec<br/>           Gear ratio [i]: 1:1<br/>           Torque max [Nm]: 32/Sp<br/>           Rotation max [1/min]: 12000<br/>           Rotating direction: same<br/>           Coolant: IC/Ext<br/>           Pressure max [bar]: 140<br/>           Center distance [mm]: 75</p> |
| <b>8 100 15 001</b> | <b>Tool holder radial ø17,1 / minus</b>       |   |
|                     |   | <p>Employment for: Angle handpiece or extension CN01<br/>           Tool drive: Flat (~DIN 1809)<br/>           Shank size [mm]: 55.00<br/>           Shank type: BMT<br/>           Tool adaption: Interface ø17,1 / M17x1<br/>           Gear ratio [i]: 1:2<br/>           Rotation max [1/min]: 12000<br/>           Rotating direction: same<br/>           Coolant: no<br/>           Center distance [mm]: 77</p>   |
| <b>8 102 15 000</b> | <b>Tool holder Ø 17</b>                       |   |
|                     |   | <p>Weight [kg]: 1.930<br/>           Employment for: Angle handpiece<br/>           Tool drive: Flat (~DIN 1809)<br/>           Shank size [mm]: 55.00<br/>           Shank type: BMT<br/>           Tool adaption: Interface 17<br/>           Gear ratio [i]: 1:1<br/>           Rotation max [1/min]: 6000<br/>           Rotating direction: same<br/>           Coolant: no</p>   |
| <b>8 200 03 002</b> | <b>Cover plate</b>                            |   |
|                     |   | <p>Weight [kg]: 0.300<br/>           Shank type: BMT</p>   |
| <b>8 202 10 006</b> | <b>Basic holder longitudinal seat FN 12</b>   |   |
|                     |   | <p>Weight [kg]: 0.960<br/>           Notation: 180° reversible<br/>           Shank type: BMT<br/>           Machine adaption: Centering key b 20<br/>           Tool adaption: Interface FN 12<br/>           Coolant: EXT</p>  |

# Nakamura

## Super NTJ-unterer Revolver

| Part-#              | Name   |                    |
|---------------------|--|--------------------|
| <b>8 208 59 003</b> | <b>Test mandrel BMT 55</b>                     |                    |
|                     | Weight [kg]:                                   | 3.080              |
|                     | Shank size [mm]:                               | 55.00              |
|                     | Shank type:                                    | BMT                |
| <b>8 209 10 000</b> | <b>Tool blank</b>                              |                    |
|                     | Weight [kg]:                                   | 4.580              |
|                     | Shank type:                                    | BMT                |
|                     | Machine adaption:                              | Centering key b 20 |
|                     | Coolant:                                       | EXT                |
| <b>8 209 11 000</b> | <b>Adapter for VDI 20</b>                      |                    |
|                     | Shank type:                                    | BMT                |
|                     | Machine adaption:                              | Centering key b 20 |
|                     | Tool adaption:                                 | DIN 69880 - 20     |
|                     | Coolant:                                       | EXT                |
|                     | Center distance [mm]:                          | 55                 |
| <b>8 209 12 000</b> | <b>Adapter for VDI 30</b>                      |                    |
|                     | Weight [kg]:                                   | 2.750              |
|                     | Employment for:                                | Outside operation  |
|                     | Shank type:                                    | BMT                |
|                     | Machine adaption:                              | Centering key b 20 |
|                     | Tool adaption:                                 | DIN 69880 - 30     |
|                     | Coolant:                                       | EXT                |
|                     | Center distance [mm]:                          | 35                 |
| <b>8 209 12 001</b> | <b>Adapter for VDI 30</b>                      |                    |
|                     | Weight [kg]:                                   | 3.140              |
|                     | Employment for:                                | Inside operation   |
|                     | Shank type:                                    | BMT                |
|                     | Machine adaption:                              | Centering key b 20 |
|                     | Tool adaption:                                 | DIN 69880 - 30     |
|                     | Coolant:                                       | EXT                |
|                     | Center distance [mm]:                          | 65                 |
| <b>8 209 14 002</b> | <b>Adapter for VDI 40</b>                      |                    |
|                     | Weight [kg]:                                   | 2.720              |
|                     | Shank type:                                    | BMT                |
|                     | Machine adaption:                              | Centering key b 20 |
|                     | Tool adaption:                                 | DIN 69880 - 40     |
|                     | Coolant:                                       | EXT                |
|                     | Center distance [mm]:                          | 35                 |
| <b>8 209 14 003</b> | <b>Adapter for VDI 40 offset</b>               |                    |
|                     | Shank type:                                    | BMT                |
|                     | Machine adaption:                              | Centering key b 20 |
|                     | Tool adaption:                                 | DIN 69880 - 40     |
|                     | Coolant:                                       | EXT                |
|                     | Center distance [mm]:                          | 65                 |
| <b>8 209 19 000</b> | <b>Adapter 45 ° for Ecoroll WKT EG5-1-SL00</b> |                    |
|                     | Weight [kg]:                                   | 2.590              |
|                     | Notation:                                      | 180° reversible    |
|                     | Shank type:                                    | BMT                |
|                     | Machine adaption:                              | Centering key b 20 |
|                     | Coolant:                                       | EXT                |

Nakamura  
Super NTJ-unterer Revolver

| Part-#              | Name  |                          |
|---------------------|---|--------------------------|
| <b>8 209 58 000</b> | <b>Adapter for sensor m&amp;h RWP 38.41</b> |                          |
|                     | Notation:                                   | 180° reversible          |
|                     | Shank size [mm]:                            | 55.00                    |
|                     | Shank type:                                 | BMT                      |
|                     | Tool adaption:                              | Ø 32                     |
|                     | Coolant:                                    | no                       |
| <b>8 209 58 001</b> | <b>Adapter for sensor m&amp;h IRP 40.01</b> |                          |
|                     | Weight [kg]:                                | 1.340                    |
|                     | Notation:                                   | 180° reversible          |
|                     | Shank size [mm]:                            | 55.00                    |
|                     | Shank type:                                 | BMT                      |
|                     | Tool adaption:                              | Ø 32                     |
|                     | Coolant:                                    | no                       |
| <b>8 209 58 002</b> | <b>Adapter for sensor m&amp;h IRP 40.02</b> |                          |
|                     | Weight [kg]:                                | 1.520                    |
|                     | Notation:                                   | 180° reversible          |
|                     | Shank size [mm]:                            | 55.00                    |
|                     | Shank type:                                 | BMT                      |
|                     | Coolant:                                    | no                       |
| <b>8 209 58 003</b> | <b>Adapter for sensor Renishaw RLP</b>      |                          |
|                     | Weight [kg]:                                | 1.700                    |
|                     | Notation:                                   | 180° reversible          |
|                     | Shank size [mm]:                            | 55.00                    |
|                     | Shank type:                                 | BMT                      |
|                     | Coolant:                                    | no                       |
| <b>8 224 11 002</b> | <b>Turning holder sq. 20</b>                |                          |
|                     | Weight [kg]:                                | 2.420                    |
|                     | Employment for:                             | right cutting tools      |
|                     | Shank type:                                 | BMT                      |
|                     | Machine adaption:                           | Centering key b 20       |
|                     | Tool adaption:                              | Sq. 20                   |
|                     | Coolant:                                    | EXT                      |
| <b>8 224 11 003</b> | <b>Cut-off holder sq. 20</b>                |                          |
|                     | Weight [kg]:                                | 1.040                    |
|                     | Employment for:                             | right cutting tools      |
|                     | Version:                                    | Edge on side of turret   |
|                     | Shank type:                                 | BMT                      |
|                     | Machine adaption:                           | Centering key b 20       |
|                     | Tool adaption:                              | Sq. 20                   |
|                     | Coolant:                                    | EXT                      |
| <b>8 224 11 005</b> | <b>Cut-off holder sq. 20</b>                |                          |
|                     | Weight [kg]:                                | 1.100                    |
|                     | Employment for:                             | left cutting tools       |
|                     | Version:                                    | Edge on center of turret |
|                     | Shank type:                                 | BMT                      |
|                     | Machine adaption:                           | Centering key b 20       |
|                     | Tool adaption:                              | Sq. 20                   |
|                     | Coolant:                                    | EXT                      |

| Part-#  | Name                                  |                             |
|---|---------------------------------------|-----------------------------|
| <b>8 224 11 016</b>   | <b>Cut-off holder sq. 3/4" R 1441</b> |                             |
|   | Weight [kg]:                          | 1.110                       |
|   | Employment for:                       | right cutting tools         |
|   | Version:                              | Edge on side of turret      |
|   | Shank type:                           | BMT                         |
|   | Machine adaption:                     | Centering key b 20          |
|   | Tool adaption:                        | Sq. 3/4" (19,05mm)          |
|   | Coolant:                              | EXT                         |
| <b>8 224 11 022</b>   | <b>Cut-off holder sq. 20</b>          |                             |
|    | Weight [kg]:                          | 1.350                       |
|   | Employment for:                       | right cutting tools         |
|   | Version:                              | Edge on side of turret      |
|   | Shank type:                           | BMT                         |
|   | Machine adaption:                     | Centering key b 20          |
|   | Tool adaption:                        | Sq. 20                      |
|   | Coolant:                              | EXT                         |
| <b>8 224 12 005</b>   | <b>Cut-off holder sq. 25</b>          |                             |
|   | Weight [kg]:                          | 1.480                       |
|   | Shank type:                           | BMT                         |
|   | Machine adaption:                     | Centering key b 20          |
|   | Tool adaption:                        | Sq. 25                      |
|   | Coolant:                              | EXT                         |
| <b>8 224 13 004</b>   | <b>Cut-off holder SH 32</b>           |                             |
|   | Weight [kg]:                          | 1.000                       |
|   | Employment for:                       | Cut-off tool 32             |
|   | Version:                              | Clampshaft on turret center |
|   | Shank type:                           | BMT                         |
|   | Machine adaption:                     | Centering key b 20          |
|   | Tool adaption:                        | Clampshaft SH 32            |
|   | Coolant:                              | EXT                         |
| <b>8 224 13 007</b>   | <b>Cut-off holder SH 32</b>           |                             |
|  | Weight [kg]:                          | 1.190                       |
|   | Employment for:                       | Cut-off tool 32             |
|   | Version:                              | Clampshaft on turret side   |
|   | Shank type:                           | BMT                         |
|   | Machine adaption:                     | Centering key b 20          |
|   | Tool adaption:                        | Clampshaft SH 32            |
|   | Coolant:                              | EXT                         |
| <b>8 224 13 013</b>   | <b>Cut-off holder SH 32</b>           |                             |
|   | Weight [kg]:                          | 1.480                       |
|   | Employment for:                       | Cut-off tool 32             |
|   | Version:                              | Clampshaft on turret side   |
|   | Shank type:                           | BMT                         |
|   | Machine adaption:                     | Centering key b 20          |
|   | Tool adaption:                        | Clampshaft SH 32            |
|   | Coolant:                              | EXT                         |
|   | Please note:                          | Special                     |

| Part-#  | Name                                      |  |
|---|---|--|
| <b>8 224 13 021</b>   | <b>Cut-off holder SH 32 IC</b>            |  |
|   | Weight [kg]:                              | 1.030                                      |
|   | Employment for:                           | Cut-off tool 32                            |
|   | Version:                                  | Clampshaft on turret center                |
|   | Shank type:                               | BMT  |
|   | Machine adaption:                         | Centering key b 20                         |
|   | Tool adaption:                            | Clampshaft SH 32                           |
|   | Coolant:                                  | IC/Ext                                     |
| <b>8 224 14 000</b>   | <b>Universal turning holder sq. 20</b>    |  |
|   | Weight [kg]:                              | 1.730                                      |
|   | Notation:                                 | 180° reversible                            |
|   | Shank type:                               | BMT  |
|   | Machine adaption:                         | Centering key b 20                         |
|   | Tool adaption:                            | Sq. 20                                     |
|   |   | Sq. 20                                     |
|   | Coolant:                                  | EXT  |
|   | Please note:                              | with spacer strip                          |
| <b>8 224 14 016</b>   | <b>Universal turning holder sq. 20 IC</b> |  |
|   | Weight [kg]:                              | 2.950                                      |
|   | Notation:                                 | 180° reversible                            |
|   | Shank type:                               | BMT  |
|   | Machine adaption:                         | Centering key b 20                         |
|   | Tool adaption:                            | Sq. 20                                     |
|   | Coolant:                                  | IC/Ext                                     |
|   | Pressure max [bar]:                       | 100  |
|   | Please note:                              | Key rail                                   |
| <b>8 224 15 002</b>   | <b>Universal turning holder sq. 25/20</b> |  |
|  | Weight [kg]:                              | 2.800                                      |
|   | Notation:                                 | 180° reversible                            |
|   | Shank type:                               | BMT  |
|   | Machine adaption:                         | Centering key b 20                         |
|   | Tool adaption:                            | Sq. 25                                     |
|   |   | Sq. 25                                     |
|   | Coolant:                                  | EXT  |
|   | Please note:                              | With spacer strip for sq. 20               |
| <b>8 224 15 012</b>   | <b>Universal turning holder sq. 1"</b>    |  |
|   | Weight [kg]:                              | 2.720                                      |
|   | Shank type:                               | BMT  |
|   | Machine adaption:                         | Centering key b 20                         |
|   | Tool adaption:                            | Sq. 1" (25,4mm)                            |
|   |   | Sq. 1" (25,4mm)                            |
|   | Coolant:                                  | EXT  |
| <b>8 224 15 046</b>   | <b>Universal turning holder sq. 25/20</b> |  |
|   | Weight [kg]:                              | 5.520                                      |
|   | Shank type:                               | BMT  |
|   | Machine adaption:                         | Centering key b 20                         |
|   | Tool adaption:                            | Sq. 25                                     |
|   |   | Sq. 25                                     |
|   | Coolant:                                  | EXT  |
|   | Please note:                              | Check applicability! with spacer strip for |

| Part-#  | Name                                      |                          |
|---|---|--------------------------|
| <b>8 224 15 062</b>   | <b>Universal turning holder sq. 25 IC</b> |                          |
|  | Weight [kg]:                              | 3.100                    |
|   | Shank type:                               | BMT                      |
|   | Machine adaption:                         | Centering key b 20       |
|   | Tool adaption:                            | Sq. 25                   |
|   |   | Sq. 25                   |
|   | Coolant:                                  | IC/Ext                   |
|   | Pressure max [bar]:                       | 100                      |
|   | Please note:                              | Key rail                 |
| <b>8 224 15 063</b>   | <b>Universal turning holder sq. 1" IC</b> |                          |
|  | Weight [kg]:                              | 3.100                    |
|   | Shank type:                               | BMT                      |
|   | Machine adaption:                         | Centering key b 20       |
|   | Tool adaption:                            | Sq. 1" (25,4mm)          |
|   |   | Sq. 1" (25,4mm)          |
|   | Coolant:                                  | IC/Ext                   |
|   | Pressure max [bar]:                       | 100                      |
|   | Please note:                              | Key rail                 |
| <b>8 225 11 002</b>   | <b>Cut-off holder sq. 20 R 1432</b>       |                          |
|   | Weight [kg]:                              | 1.120                    |
|   | Employment for:                           | left cutting tools       |
|   | Version:                                  | Edge on side of turret   |
|   | Shank type:                               | BMT                      |
|   | Machine adaption:                         | Centering key b 20       |
|   | Tool adaption:                            | Sq. 20                   |
|   | Coolant:                                  | EXT                      |
| <b>8 225 11 005</b>   | <b>Cut-off holder sq. 20</b>              |                          |
|   | Weight [kg]:                              | 1.170                    |
|   | Employment for:                           | right cutting tools      |
|   | Version:                                  | Edge on center of turret |
|   | Shank type:                               | BMT                      |
|   | Machine adaption:                         | Centering key b 20       |
|   | Tool adaption:                            | Sq. 20                   |
|   | Coolant:                                  | EXT                      |
| <b>8 225 11 009</b>   | <b>Cut-off holder sq. 3/4" R 1442</b>     |                          |
|   | Weight [kg]:                              | 1.110                    |
|   | Employment for:                           | left cutting tools       |
|   | Version:                                  | Edge on side of turret   |
|   | Shank type:                               | BMT                      |
|   | Machine adaption:                         | Centering key b 20       |
|   | Tool adaption:                            | Sq. 3/4" (19,05mm)       |
|   | Coolant:                                  | EXT                      |
| <b>8 225 11 012</b>   | <b>Cut-off holder sq. 3/4"</b>            |                          |
|   | Weight [kg]:                              | 1.200                    |
|   | Employment for:                           | right cutting tools      |
|   | Version:                                  | Edge on center of turret |
|   | Shank type:                               | BMT                      |
|   | Machine adaption:                         | Centering key b 20       |
|   | Tool adaption:                            | Sq. 3/4" (19,05mm)       |
|   | Coolant:                                  | EXT                      |

Nakamura  
Super NTJ-unterer Revolver

| Part-#              | Name                      |  |
|---------------------|---------------------------|--|
| <b>8 229 16 001</b> | <b>Tool holder C 4 IC</b> |  |
|                     | Weight [kg]:              | 2.400                                  |
|                     | Notation:                 | 180° reversible                        |
|                     | Version:                  | right                                  |
|                     | Shank type:               | BMT                                    |
|                     | Machine adaption:         | Centering key b 20                     |
|                     | Tool adaption:            | heimatec Capto(TM) C 4                 |
|                     | Coolant:                  | IC/Ext                                 |
|                     | Please note:              | Check applicability; note tool length! |
|                     | Offset [mm]:              | 12                                     |
| <b>8 229 16 003</b> | <b>Tool holder C 4 IC</b> |  |
|                     | Weight [kg]:              | 3.330                                  |
|                     | Notation:                 | 180° reversible                        |
|                     | Version:                  | right                                  |
|                     | Shank type:               | BMT                                    |
|                     | Machine adaption:         | Centering key b 20                     |
|                     | Tool adaption:            | heimatec Capto(TM) C 4                 |
|                     | Coolant:                  | IC/Ext                                 |
|                     | Please note:              | Check applicability; note tool length! |
|                     | Offset [mm]:              | 55                                     |
| <b>8 229 16 008</b> | <b>Tool holder C 4 IC</b> |  |
|                     | Weight [kg]:              | 3.430                                  |
|                     | Notation:                 | 180° reversible                        |
|                     | Version:                  | right                                  |
|                     | Shank type:               | BMT                                    |
|                     | Machine adaption:         | Centering key b 20                     |
|                     | Tool adaption:            | heimatec Capto(TM) C 4                 |
|                     | Coolant:                  | IC                                     |
|                     | Please note:              | Check applicability; note tool length! |
|                     | Offset [mm]:              | 55                                     |
| <b>8 229 16 009</b> | <b>Tool holder C 4 IC</b> |  |
|                     | Weight [kg]:              | 2.410                                  |
|                     | Notation:                 | 180° reversible                        |
|                     | Version:                  | right                                  |
|                     | Shank type:               | BMT                                    |
|                     | Machine adaption:         | Centering key b 20                     |
|                     | Tool adaption:            | heimatec Capto(TM) C 4                 |
|                     | Coolant:                  | IC                                     |
|                     | Please note:              | Check applicability; note tool length! |
|                     | Offset [mm]:              | 12                                     |
| <b>8 229 16 011</b> | <b>Tool holder C 4 IC</b> |  |
|                     | Weight [kg]:              | 3.440                                  |
|                     | Notation:                 | 180° reversible                        |
|                     | Version:                  | left                                   |
|                     | Shank type:               | BMT                                    |
|                     | Machine adaption:         | Centering key b 20                     |
|                     | Tool adaption:            | heimatec Capto(TM) C 4                 |
|                     | Coolant:                  | IC                                     |
|                     | Please note:              | Check applicability; note tool length! |
|                     | Offset [mm]:              | 55                                     |

| Part-#  | Name                                    |  |
|---|---|--|
| <b>8 229 17 003</b>   | <b>Tool holder C 5 IC</b>               |  |
|   | Notation:                               | 180° reversible                        |
|   | Version:                                | right                                  |
|   | Shank type:                             | BMT                                    |
|   | Machine adaption:                       | Centering key b 20                     |
|   | Tool adaption:                          | heimatec Capto(TM) C 5                 |
|   | Coolant:                                | IC                                     |
|   | Please note:                            | Check applicability; note tool length! |
|   | Offset [mm]:                            | 64                                     |
| <b>8 240 14 017</b>   | <b>Boring bar holder Ø 12 - slotted</b> |  |
|    | Weight [kg]:                            | 2.900                                  |
|   | Notation:                               | 180° reversible                        |
|   | Version:                                | slotted                                |
|   | Shank type:                             | BMT                                    |
|   | Machine adaption:                       | Centering key b 20                     |
|   | Tool adaption:                          | Ø 12                                   |
|   | Coolant:                                | EXT                                    |
|   | Pressure max [bar]:                     | 100                                    |
|   | Center distance [mm]:                   | 75                                     |
| <b>8 240 14 022</b>   | <b>Boring bar holder Ø 10 - slotted</b> |  |
|  | Weight [kg]:                            | 2.900                                  |
|   | Notation:                               | 180° reversible                        |
|   | Version:                                | slotted                                |
|   | Shank type:                             | BMT                                    |
|   | Machine adaption:                       | Centering key b 20                     |
|   | Tool adaption:                          | Ø 10                                   |
|   | Coolant:                                | EXT                                    |
|   | Pressure max [bar]:                     | 100                                    |
|   | Center distance [mm]:                   | 75                                     |
| <b>8 240 15 002</b>   | <b>Tool holder ABS 50 IC/Ext</b>        |  |
|   | Weight [kg]:                            | 3.560                                  |
|   | Notation:                               | offset                                 |
|   | Shank type:                             | BMT                                    |
|   | Machine adaption:                       | Centering key b 20                     |
|   | Tool adaption:                          | ABS 50                                 |
|   | Coolant:                                | IC/Ext                                 |
|   | Center distance [mm]:                   | 75                                     |
| <b>8 240 15 004</b>   | <b>Tool holder C 3 IC</b>               |  |
|   | Weight [kg]:                            | 3.580                                  |
|   | Notation:                               | 180° reversible; offset                |
|   | Shank type:                             | BMT                                    |
|   | Machine adaption:                       | Centering key b 20                     |
|   | Tool adaption:                          | heimatec Capto(TM) C 3                 |
|   | Coolant:                                | IC                                     |
|   | Center distance [mm]:                   | 75                                     |
| <b>8 240 15 005</b>   | <b>Tool holder C 3 offset</b>           |  |
|   | Version:                                | Special                                |
|   | Shank type:                             | BMT                                    |
|   | Machine adaption:                       | Centering key b 20                     |
|   | Tool adaption:                          | heimatec Capto(TM) C 3                 |
|   | Coolant:                                | IC/Ext                                 |
|   | Center distance [mm]:                   | 75                                     |

| Part-#              | Name                                      |                               |
|---------------------|---|-------------------------------|
| <b>8 240 15 007</b> | <b>Insert drill holder 16 IC</b>          |                               |
|                     | Weight [kg]:                              | 4.540                         |
|                     | Notation:                                 | 180° reversible               |
|                     | Shank type:                               | BMT                           |
|                     | Tool adaption:                            | Whistle-Notch (DIN 1835 E) 16 |
|                     | Coolant:                                  | IC                            |
|                     | Center distance [mm]:                     | 75                            |
| <b>8 240 15 019</b> | <b>Collet chuck holder ER 25 AX UT IC</b> |                               |
|                     | Weight [kg]:                              | 3.380                         |
|                     | Notation:                                 | 180° reversible; offset       |
|                     | Shank type:                               | BMT                           |
|                     | Machine adaption:                         | Centering key b 20            |
|                     | Tool adaption:                            | ER 25 A - u-tec               |
|                     | Coolant:                                  | IC/Ext                        |
|                     | Center distance [mm]:                     | 75                            |
| <b>8 240 15 039</b> | <b>Boring bar holder Ø 16 - slotted</b>   |                               |
|                     | Weight [kg]:                              | 3.000                         |
|                     | Notation:                                 | 180° reversible               |
|                     | Shank type:                               | BMT                           |
|                     | Machine adaption:                         | Centering key b 20            |
|                     | Tool adaption:                            | Ø 16                          |
|                     | Coolant:                                  | EXT                           |
|                     | Center distance [mm]:                     | 75                            |
| <b>8 240 16 004</b> | <b>Tool holder HT 4 IC</b>                |                               |
|                     | Weight [kg]:                              | 2.890                         |
|                     | Notation:                                 | 180° reversible; offset       |
|                     | Shank type:                               | BMT                           |
|                     | Machine adaption:                         | Centering key b 20            |
|                     | Tool adaption:                            | HT 4                          |
|                     | Coolant:                                  | IC/Ext                        |
|                     | Center distance [mm]:                     | 75                            |
| <b>8 240 16 006</b> | <b>Tool holder HT 4 IC</b>                |                               |
|                     | Weight [kg]:                              | 3.340                         |
|                     | Notation:                                 | offset                        |
|                     | Version:                                  | Special                       |
|                     | Shank type:                               | BMT                           |
|                     | Machine adaption:                         | Centering key b 20            |
|                     | Tool adaption:                            | HT 4                          |
|                     | Coolant:                                  | IC/Ext                        |
|                     | Center distance [mm]:                     | 75                            |
| <b>8 240 16 009</b> | <b>Insert drill holder 20 IC</b>          |                               |
|                     | Weight [kg]:                              | 4.480                         |
|                     | Notation:                                 | 180° reversible               |
|                     | Shank type:                               | BMT                           |
|                     | Tool adaption:                            | Whistle-Notch (DIN 1835 E) 20 |
|                     | Coolant:                                  | IC                            |
|                     | Center distance [mm]:                     | 75                            |

| Part-#  | Name                       |  |
|---|----------------------------|--|
| <b>8 240 16 020</b>   | <b>Tool holder HT 4 IC</b> |  |
|   | Weight [kg]:               | 5.900                                  |
|   | Notation:                  | offset; 180° reversible                |
|   | Version:                   | Special                                |
|   | Shank type:                | BMT                                    |
|   | Machine adaption:          | Centering key b 20                     |
|   | Tool adaption:             | HT 4                                   |
|   | Coolant:                   | IC/Ext                                 |
|   | Center distance [mm]:      | 75                                     |
| <b>8 240 16 040</b>   | <b>Tool holder C 4 IC</b>  |  |
|   | Weight [kg]:               | 3.130                                  |
|   | Notation:                  | 180° reversible                        |
|   | Version:                   | offset; right                          |
|   | Shank type:                | BMT                                    |
|   | Machine adaption:          | Centering key b 20                     |
|   | Tool adaption:             | heimatec Capto(TM) C 4                 |
|   | Coolant:                   | IC/Ext                                 |
|   | Please note:               | Check applicability; note tool length! |
|   | Center distance [mm]:      | 75                                     |
| <b>8 240 16 045</b>   | <b>Tool holder C 4 IC</b>  |  |
|  | Weight [kg]:               | 2.960                                  |
|   | Notation:                  | 180° reversible                        |
|   | Version:                   | offset; right                          |
|   | Shank type:                | BMT                                    |
|   | Machine adaption:          | Centering key b 20                     |
|   | Tool adaption:             | heimatec Capto(TM) C 4                 |
|   | Coolant:                   | IC                                     |
|   | Please note:               | Check applicability; note tool length! |
|   | Center distance [mm]:      | 75                                     |
| <b>8 240 16 046</b>   | <b>Tool holder C 4 IC</b>  |  |
|   | Weight [kg]:               | 3.480                                  |
|   | Notation:                  | 180° reversible                        |
|   | Version:                   | right                                  |
|   | Shank type:                | BMT                                    |
|   | Machine adaption:          | Centering key b 20                     |
|   | Tool adaption:             | heimatec Capto(TM) C 4                 |
|   | Coolant:                   | IC                                     |
|   | Please note:               | Check applicability; note tool length! |
|   | Center distance [mm]:      | 75                                     |
| <b>8 240 16 051</b>   | <b>Tool holder C 4 IC</b>  |  |
|   | Weight [kg]:               | 3.430                                  |
|   | Notation:                  | 180° reversible                        |
|   | Version:                   | left                                   |
|   | Shank type:                | BMT                                    |
|   | Machine adaption:          | Centering key b 20                     |
|   | Tool adaption:             | heimatec Capto(TM) C 4                 |
|   | Coolant:                   | IC                                     |
|   | Please note:               | Check applicability; note tool length! |
|   | Center distance [mm]:      | 75                                     |

# Nakamura Super NTJ-unterer Revolver

| Part-#  | Name                                    |  |
|---|---|--|
| <b>8 240 16 054</b>   | <b>Tool holder C 4 IC</b>               |  |
|    | Weight [kg]:                            | 2.840                                  |
|   | Notation:                               | 180° reversible                        |
|   | Version:                                | left; special                          |
|   | Shank type:                             | BMT                                    |
|   | Machine adaption:                       | Centering key b 20                     |
|   | Tool adaption:                          | heimatec Capto(TM) C 4                 |
|   | Coolant:                                | IC/Ext                                 |
|   | Please note:                            | Check applicability; note tool length! |
|   | Center distance [mm]:                   | 40                                     |
| <b>8 240 16 072</b>   | <b>Tool holder C 4 IC</b>               |  |
|    | Weight [kg]:                            | 4.000                                  |
|   | Notation:                               | 180° reversible                        |
|   | Version:                                | right                                  |
|   | Shank type:                             | BMT                                    |
|   | Machine adaption:                       | Centering key b 20                     |
|   | Tool adaption:                          | heimatec Capto(TM) C 4                 |
|   | Coolant:                                | IC                                     |
|   | Please note:                            | Check applicability; note tool length! |
|   | Center distance [mm]:                   | 95                                     |
| <b>8 240 16 077</b>   | <b>Boring bar holder Ø 20 - slotted</b> |  |
|  | Weight [kg]:                            | 3.120                                  |
|   | Notation:                               | 180° reversible                        |
|   | Version:                                | slotted                                |
|   | Shank type:                             | BMT                                    |
|   | Machine adaption:                       | Centering key b 20                     |
|   | Tool adaption:                          | Ø 20                                   |
|   | Coolant:                                | EXT                                    |
|   | Pressure max [bar]:                     | 100                                    |
|   | Center distance [mm]:                   | 75                                     |
| <b>8 240 17 005</b>   | <b>Boring bar holder Ø 25</b>           |  |
|  | Weight [kg]:                            | 3.820                                  |
|   | Notation:                               | 180° reversible                        |
|   | Shank type:                             | BMT                                    |
|   | Machine adaption:                       | Centering key b 20                     |
|   | Tool adaption:                          | Ø 25                                   |
|   | Coolant:                                | IC/Ext                                 |
|   | Please note:                            | Housing rigid                          |
|   | Center distance [mm]:                   | 75                                     |
| <b>8 240 17 023</b>   | <b>Insert drill holder 25 IC</b>        |  |
|   | Weight [kg]:                            | 4.380                                  |
|   | Notation:                               | 180° reversible                        |
|   | Shank type:                             | BMT                                    |
|   | Tool adaption:                          | Whistle-Notch (DIN 1835 E) 25          |
|   | Coolant:                                | IC                                     |
|   | Center distance [mm]:                   | 75                                     |

| Part-#              | Name  |                    |
|---------------------|---|--------------------|
| <b>8 240 17 031</b> | <b>Boring bar holder Ø 30</b>               |                    |
|                     | Notation:                                   | 180° reversible    |
|                     | Version:                                    | Special            |
|                     | Shank type:                                 | BMT                |
|                     | Machine adaption:                           | Centering key b 20 |
|                     | Tool adaption:                              | Ø 30               |
|                     | Coolant:                                    | EXT                |
|                     | Center distance [mm]:                       | 112                |
| <b>8 240 17 032</b> | <b>Boring bar holder Ø 30</b>               |                    |
|                     | Notation:                                   | 180° reversible    |
|                     | Version:                                    | Special            |
|                     | Shank type:                                 | BMT                |
|                     | Machine adaption:                           | Centering key b 20 |
|                     | Tool adaption:                              | Ø 30               |
|                     | Coolant:                                    | EXT                |
|                     | Center distance [mm]:                       | 105                |
| <b>8 240 17 052</b> | <b>Boring bar holder Ø 25</b>               |                    |
|                     | Weight [kg]:                                | 4.430              |
|                     | Employment for:                             | Main spindle       |
|                     | Version:                                    | long; special      |
|                     | Shank type:                                 | BMT                |
|                     | Machine adaption:                           | Centering key b 20 |
|                     | Tool adaption:                              | Ø 25               |
|                     | Coolant:                                    | IC/Ext             |
|                     | Center distance [mm]:                       | 75                 |
| <b>8 240 17 061</b> | <b>Boring bar holder Ø 1"</b>               |                    |
|                     | Weight [kg]:                                | 2.300              |
|                     | Shank type:                                 | BMT                |
|                     | Machine adaption:                           | Centering key b 20 |
|                     | Tool adaption:                              | Ø 1" (25,4mm)      |
|                     | Coolant:                                    | IC/Ext             |
|                     | Center distance [mm]:                       | 55                 |
| <b>8 240 17 065</b> | <b>Boring bar holder Ø 25 - slotted</b>     |                    |
|                     | Weight [kg]:                                | 3.670              |
|                     | Notation:                                   | 180° reversible    |
|                     | Shank type:                                 | BMT                |
|                     | Machine adaption:                           | Centering key b 20 |
|                     | Tool adaption:                              | Ø 25               |
|                     | Coolant:                                    | EXT                |
|                     | Please note:                                | Housing rigid      |
|                     | Center distance [mm]:                       | 75                 |
| <b>8 240 17 078</b> | <b>Boring bar holder Ø 1 1/4" - slotted</b> |                    |
|                     | Weight [kg]:                                | 3.440              |
|                     | Notation:                                   | 180° reversible    |
|                     | Shank type:                                 | BMT                |
|                     | Machine adaption:                           | Centering key b 20 |
|                     | Tool adaption:                              | Ø 1 1/4" (31,75mm) |
|                     | Coolant:                                    | EXT                |
|                     | Please note:                                | Housing rigid      |
|                     | Center distance [mm]:                       | 75                 |

# Nakamura

## Super NTJ-unterer Revolver

| Part-#  | Name                              |  |
|---|-----------------------------------|--|
| <b>8 240 17 096</b>   | <b>Tool holder C 5 IC</b>         |  |
|   | Weight [kg]:                      | 5.030                                  |
|   | Notation:                         | 180° reversible                        |
|   | Version:                          | right                                  |
|   | Shank type:                       | BMT                                    |
|   | Machine adaption:                 | Centering key b 20                     |
|   | Tool adaption:                    | heimatec Capto(TM) C 5                 |
|   | Coolant:                          | IC                                     |
|   | Please note:                      | Check applicability; note tool length! |
|   | Center distance [mm]:             | 75                                     |
| <b>8 240 17 106</b>   | <b>Boring bar holder Ø 25</b>     |  |
|    | Weight [kg]:                      | 4.800                                  |
|   | Notation:                         | 180° reversible                        |
|   | Shank type:                       | BMT                                    |
|   | Machine adaption:                 | Centering key b 20                     |
|   | Tool adaption:                    | Ø 25                                   |
|   | Coolant:                          | IC/Ext                                 |
|   | Please note:                      | Check applicability! housing rigid     |
|   | Center distance [mm]:             | 95                                     |
| <b>8 240 17 114</b>   | <b>Boring bar holder Ø 1"</b>     |  |
|  | Weight [kg]:                      | 4.760                                  |
|   | Notation:                         | 180° reversible                        |
|   | Shank type:                       | BMT                                    |
|   | Machine adaption:                 | Centering key b 20                     |
|   | Tool adaption:                    | Ø 1" (25,4mm)                          |
|   | Coolant:                          | IC/Ext                                 |
|   | Please note:                      | Check applicability! housing rigid     |
|   | Center distance [mm]:             | 95                                     |
| <b>8 240 17 115</b>   | <b>Boring bar holder Ø 1 1/4"</b> |  |
|  | Weight [kg]:                      | 4.620                                  |
|   | Notation:                         | 180° reversible                        |
|   | Shank type:                       | BMT                                    |
|   | Machine adaption:                 | Centering key b 20                     |
|   | Tool adaption:                    | Ø 1 1/4" (31,75mm)                     |
|   | Coolant:                          | IC/Ext                                 |
|   | Please note:                      | Check applicability! housing rigid     |
|   | Center distance [mm]:             | 95                                     |
| <b>8 240 18 010</b>   | <b>Boring bar holder Ø 32</b>     |  |
|  | Weight [kg]:                      | 3.640                                  |
|   | Notation:                         | 180° reversible                        |
|   | Shank type:                       | BMT                                    |
|   | Machine adaption:                 | Centering key b 20                     |
|   | Tool adaption:                    | Ø 32                                   |
|   | Coolant:                          | IC/Ext                                 |
|   | Pressure max [bar]:               | 140                                    |
|   | Please note:                      | Housing rigid                          |
|   | Center distance [mm]:             | 75                                     |



# Nakamura

## Super NTJ-unterer Revolver

| Part-#              | Name                                 |  |
|---------------------|--------------------------------------|--|
| <b>8 240 18 011</b> | <b>Boring bar holder Ø 32</b>        |  |
|                     | Weight [kg]:                         | 2.680  |
|                     | Shank type:                          | BMT  |
|                     | Machine adaption:                    | Centering key b 20                                     |
|                     | Tool adaption:                       | Ø 32   |
|                     | Coolant:                             | IC/Ext   |
|                     | Center distance [mm]:                | 55   |
| <b>8 240 18 016</b> | <b>Boring bar holder Ø 32</b>        |  |
|                     | Weight [kg]:                         | 4.370  |
|                     | Notation:                            | 180° reversible  |
|                     | Shank type:                          | BMT  |
|                     | Machine adaption:                    | Centering key b 20                                     |
|                     | Tool adaption:                       | Ø 32   |
|                     | Coolant:                             | IC/Ext   |
|                     | Please note:                         | Housing rigid  |
|                     | Center distance [mm]:                | 90   |
| <b>8 240 18 021</b> | <b>Insert drill holder 32 IC</b>     |  |
|                     | Weight [kg]:                         | 4.200  |
|                     | Notation:                            | 180° reversible  |
|                     | Shank type:                          | BMT  |
|                     | Tool adaption:                       | Whistle-Notch (DIN 1835 E) 32                          |
|                     | Coolant:                             | IC   |
|                     | Center distance [mm]:                | 75   |
| <b>8 240 18 085</b> | <b>Boring bar holder Ø 32</b>        |  |
|                     | Weight [kg]:                         | 4.605  |
|                     | Notation:                            | 180° reversible  |
|                     | Shank type:                          | BMT  |
|                     | Machine adaption:                    | Centering key b 20                                     |
|                     | Tool adaption:                       | Ø 32   |
|                     | Coolant:                             | IC/Ext   |
|                     | Please note:                         | Check applicability! housing rigid                     |
|                     | Center distance [mm]:                | 95   |
| <b>8 240 18 088</b> | <b>Boring bar holder Ø 32 offset</b> |  |
|                     | Weight [kg]:                         | 4.200  |
|                     | Notation:                            | offset   |
|                     | Shank type:                          | BMT  |
|                     | Machine adaption:                    | Centering key b 20                                     |
|                     | Tool adaption:                       | Ø 32   |
|                     | Coolant:                             | IC/Ext   |
|                     | Please note:                         | Front edge ø32- adapter 20mm from turret center offset |
|                     | Center distance [mm]:                | 75   |
| <b>8 240 18 102</b> | <b>Boring bar holder Ø 32 offset</b> |  |
|                     | Weight [kg]:                         | 6.780  |
|                     | Notation:                            | 180° reversible  |
|                     | Version:                             | offset   |
|                     | Shank type:                          | BMT  |
|                     | Machine adaption:                    | Centering key b 20                                     |
|                     | Tool adaption:                       | Ø 32   |
|                     | Coolant:                             | IC   |
|                     | Pressure max [bar]:                  | 100  |
|                     | Please note:                         | Check applicability! length                            |
|                     | Center distance [mm]:                | 80   |



| Part-#  | Name                                 |  |
|---|--------------------------------------|--|
| <b>8 240 19 142</b>   | <b>Boring bar holder Ø 40 offset</b> |  |
|    | Weight [kg]:                         | 5.000  |
|   | Notation:                            | offset   |
|   | Shank type:                          | BMT  |
|   | Machine adaption:                    | Centering key b 20                                     |
|   | Tool adaption:                       | Ø 40   |
|   | Coolant:                             | IC/Ext   |
|   | Please note:                         | Front edge Ø40- adapter 60mm from turret center offset |
|   | Center distance [mm]:                | 75   |
| <b>8 240 19 143</b>   | <b>Boring bar holder Ø 40 offset</b> |  |
|    | Weight [kg]:                         | 4.000  |
|   | Notation:                            | offset   |
|   | Shank type:                          | BMT  |
|   | Machine adaption:                    | Centering key b 20                                     |
|   | Tool adaption:                       | Ø 40   |
|   | Coolant:                             | IC/Ext   |
|   | Please note:                         | Front edge Ø40- adapter 20mm from turret center offset |
|   | Center distance [mm]:                | 75   |
| <b>8 244 11 002</b>   | <b>Facing holder sq. 20</b>          |  |
|   | Weight [kg]:                         | 2.340  |
|   | Notation:                            | 180° reversible  |
|   | Shank type:                          | BMT  |
|   | Machine adaption:                    | Centering key b 20                                     |
|   | Tool adaption:                       | Sq. 20   |
|   | Coolant:                             | EXT  |
| <b>8 244 11 009</b>   | <b>Facing holder sq. 20</b>          |  |
|   | Weight [kg]:                         | 4.090  |
|   | Notation:                            | 180° reversible  |
|   | Version:                             | Special; extended version                              |
|   | Shank type:                          | BMT  |
|   | Machine adaption:                    | Centering key b 20                                     |
|   | Tool adaption:                       | Sq. 20   |
|   | Coolant:                             | EXT  |
| <b>8 244 12 005</b>   | <b>Facing holder sq. 1"</b>          |  |
|   | Weight [kg]:                         | 3.570  |
|   | Shank type:                          | BMT  |
|   | Machine adaption:                    | Centering key b 20                                     |
|   | Tool adaption:                       | Sq. 1" (25,4mm)  |
|   | Coolant:                             | EXT  |
| <b>8 244 12 027</b>   | <b>Facing holder sq. 25 IC</b>       |  |
|  | Weight [kg]:                         | 3.640  |
|   | Shank type:                          | BMT  |
|   | Machine adaption:                    | Centering key b 20                                     |
|   | Tool adaption:                       | Sq. 25   |
|   | Coolant:                             | IC/Ext   |
|   | Pressure max [bar]:                  | 100  |

| Part-#  | Name                                 |  |
|---|--------------------------------------|--|
| <b>8 249 14 000</b>   | <b>Holder with square seat 12 mm</b> |  |
|   | Shank type:                          | BMT  |
|   | Machine adaption:                    | Centering key b 20                               |
|   | Tool adaption:                       | Sq. 12   |
|   | Coolant:                             | EXT  |
|   | Please note:                         | Special  |
|   | Center distance [mm]:                | 55   |
| <b>8 249 15 013</b>   | <b>Double tool holder C 3 IC</b>     |  |
|   | Weight [kg]:                         | 4.210  |
|   | Notation:                            | 180° reversible                                  |
|   | Employment for:                      | Main- and sub spindle                            |
|   | Version:                             | offset; right                                    |
|   | Shank type:                          | BMT  |
|   | Machine adaption:                    | Centering key b 20                               |
|   | Tool adaption:                       | heimatec Capto(TM) C 3<br>heimatec Capto(TM) C 3 |
|   | Coolant:                             | IC   |
|   | Please note:                         | Check applicability; note tool length!           |
|   | Center distance [mm]:                | 82,5   |
| <b>8 249 16 013</b>   | <b>Double tool holder C 4 IC</b>     |  |
|  | Weight [kg]:                         | 5.290  |
|   | Notation:                            | 180° reversible                                  |
|   | Employment for:                      | Main- and sub spindle                            |
|   | Version:                             | right  |
|   | Shank type:                          | BMT  |
|   | Machine adaption:                    | Centering key b 20                               |
|   | Tool adaption:                       | heimatec Capto(TM) C 4<br>heimatec Capto(TM) C 4 |
|   | Coolant:                             | IC/Ext   |
|   | Please note:                         | Check applicability; note tool length!           |
|   | Center distance [mm]:                | 75   |
| <b>8 249 16 015</b>   | <b>Double tool holder C 4 IC</b>     |  |
|  | Weight [kg]:                         | 5.370  |
|   | Notation:                            | 180° reversible                                  |
|   | Employment for:                      | Main- and sub spindle                            |
|   | Version:                             | right  |
|   | Shank type:                          | BMT  |
|   | Machine adaption:                    | Centering key b 20                               |
|   | Tool adaption:                       | heimatec Capto(TM) C 4<br>heimatec Capto(TM) C 4 |
|   | Coolant:                             | IC   |
|   | Please note:                         | Check applicability; note tool length!           |
|   | Center distance [mm]:                | 75   |
| <b>8 249 16 027</b>   | <b>Double tool holder C 4 IC</b>     |  |
|  | Weight [kg]:                         | 6.280  |
|   | Notation:                            | 180° reversible                                  |
|   | Employment for:                      | Main- and sub spindle                            |
|   | Version:                             | right  |
|   | Shank type:                          | BMT  |
|   | Machine adaption:                    | Centering key b 20                               |
|   | Tool adaption:                       | heimatec Capto(TM) C 4<br>heimatec Capto(TM) C 4 |
|   | Coolant:                             | IC   |

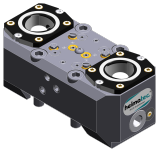



| Part-#  | Name  |  |
|---|---|--|
|   | Please note:                                | Check applicability; note tool length!           |
|   | Center distance [mm]:                       | 95   |
| <b>8 249 18 003</b>   | <b>Adapter for sensor m&amp;h IRP 40.01</b> |  |
|   | Weight [kg]:                                | 5.230  |
|   | Notation:                                   | 180° reversible                                  |
|   | Shank type:                                 | BMT  |
|   | Machine adaption:                           | Centering key b 20                               |
|   | Tool adaption:                              | Ø 32   |
|   | Coolant:                                    | no   |
|   | Center distance [mm]:                       | 112  |
| <b>8 250 15 004</b>   | <b>Multiple tool holder C 3 IC</b>          |  |
|   | Weight [kg]:                                | 4.110  |
|   | Notation:                                   | 180° reversible                                  |
|   | Employment for:                             | Main- and sub spindle                            |
|   | Version:                                    | right  |
|   | Shank type:                                 | BMT  |
|   | Machine adaption:                           | Centering key b 20                               |
|   | Tool adaption:                              | heimatec Capto(TM) C 3<br>heimatec Capto(TM) C 3 |
|   | Coolant:                                    | IC   |
|   | Please note:                                | Check applicability; note tool length!           |
|   | Offset [mm]:                                | ±55  |
| <b>8 250 16 003</b>   | <b>Multiple tool holder C 4 IC</b>          |  |
|  | Weight [kg]:                                | 4.490  |
|   | Employment for:                             | Main- and sub spindle                            |
|   | Version:                                    | right  |
|   | Shank type:                                 | BMT  |
|   | Machine adaption:                           | Centering key b 20                               |
|   | Tool adaption:                              | heimatec Capto(TM) C 4<br>heimatec Capto(TM) C 4 |
|   | Coolant:                                    | IC/Ext   |
|   | Please note:                                | Check applicability; note tool length!           |
|   | Offset [mm]:                                | ±55  |
| <b>8 250 16 005</b>   | <b>Multiple tool holder C 4 IC</b>          |  |
|   | Weight [kg]:                                | 4.620  |
|   | Employment for:                             | Main- and sub spindle                            |
|   | Version:                                    | right  |
|   | Shank type:                                 | BMT  |
|   | Machine adaption:                           | Centering key b 20                               |
|   | Tool adaption:                              | heimatec Capto(TM) C 4                           |
|   | Coolant:                                    | IC   |
|   | Please note:                                | Check applicability; note tool length!           |
|   | Offset [mm]:                                | ±55  |
| <b>8 250 16 007</b>   | <b>Double tool holder C 4 IC</b>            |  |
|   | Weight [kg]:                                | 4.630  |
|   | Notation:                                   | 180° reversible                                  |
|   | Employment for:                             | Main- and sub spindle                            |
|   | Version:                                    | left   |
|   | Shank type:                                 | BMT  |
|   | Machine adaption:                           | Centering key b 20                               |
|   | Tool adaption:                              | heimatec Capto(TM) C 4                           |
|   | Coolant:                                    | IC   |

| Part-#   | Name  |  |
|--|---|--|
|  | Please note:                                | Check applicability; note tool length! |
|  | Offset [mm]:                                | ±55                                    |
| <b>8 251 11 000</b>  | <b>Double turning holder sq. 20</b>         |  |
|  | Weight [kg]:                                | 2.250                                  |
|  | Shank type:                                 | BMT                                    |
|  | Machine adaption:                           | Centering key b 20                     |
|  | Tool adaption:                              | Sq. 20                                 |
|  | Coolant:                                    | EXT                                    |
| <b>8 251 11 003</b>  | <b>Double turning holder sq. 20</b>         |  |
|           | Weight [kg]:                                | 2.420                                  |
|  | Notation:                                   | 180° reversible                        |
|  | Employment for:                             | right cutting tools                    |
|  | Shank type:                                 | BMT                                    |
|  | Machine adaption:                           | Centering key b 20                     |
|  | Tool adaption:                              | Sq. 20                                 |
|  |   | Sq. 20                                 |
|  | Coolant:                                    | EXT                                    |
| <b>8 251 11 007</b>  | <b>Double turning holder sq. 3/4"</b>       |  |
|  | Weight [kg]:                                | 2.390                                  |
|  | Notation:                                   | 180° reversible                        |
|  | Employment for:                             | right cutting tools                    |
|  | Shank type:                                 | BMT                                    |
|  | Machine adaption:                           | Centering key b 20                     |
|  | Tool adaption:                              | Sq. 3/4" (19,05mm)                     |
|  |   | Sq. 3/4" (19,05mm)                     |
|  | Coolant:                                    | EXT                                    |
| <b>8 251 12 006</b>  | <b>Double turning holder sq. 25</b>         |  |
|  | Weight [kg]:                                | 4.910                                  |
|  | Notation:                                   | 180° reversible                        |
|  | Employment for:                             | right cutting tools                    |
|  | Shank type:                                 | BMT                                    |
|  | Machine adaption:                           | Centering key b 20                     |
|  | Tool adaption:                              | Sq. 25                                 |
|  | Coolant:                                    | EXT                                    |
| <b>8 251 13 005</b>  | <b>Combi multiple holder 6x sq. 3/4" IC</b> |  |
|  | Weight [kg]:                                | 6.300                                  |
|  | Employment for:                             | Main- and sub spindle                  |
|  | Shank type:                                 | BMT                                    |
|  | Machine adaption:                           | Centering key b 20                     |
|  | Tool adaption:                              | Sq. 3/4" (19,05mm)                     |
|  |   | Sq. 3/4" (19,05mm)                     |
|  |   | Sq. 3/4" (19,05mm)                     |
|  |   | Sq. 3/4" (19,05mm)                     |
|  | Coolant:                                    | IC/Ext                                 |
|  | Pressure max [bar]:                         | 100                                    |
|  | Please note:                                | Key rail                               |

# Nakamura

## Super NTJ-unterer Revolver

| Part-#              | Name                                      |                       |
|---------------------|---|-----------------------|
| <b>8 251 14 006</b> | <b>Combi multiple holder 6x sq. 20</b>    |                       |
|                     | Weight [kg]:                              | 6.160                 |
|                     | Notation:                                 | 180° reversible       |
|                     | Shank type:                               | BMT                   |
|                     | Machine adaption:                         | Centering key b 20    |
|                     | Tool adaption:                            | Sq. 20                |
|                     |   | Sq. 20                |
|                     |   | Sq. 20                |
|                     |   | Sq. 20                |
|                     | Coolant:                                  | EXT                   |
| <b>8 251 14 012</b> | <b>Combi multiple holder 3x sq. 20</b>    |                       |
|                     | Weight [kg]:                              | 3.800                 |
|                     | Shank type:                               | BMT                   |
|                     | Machine adaption:                         | Centering key b 20    |
|                     | Tool adaption:                            | Sq. 20                |
|                     |   | Sq. 20                |
|                     | Coolant:                                  | EXT                   |
| <b>8 251 14 018</b> | <b>Combi multiple holder 6x sq. 3/4"</b>  |                       |
|                     | Weight [kg]:                              | 6.220                 |
|                     | Notation:                                 | 180° reversible       |
|                     | Shank type:                               | BMT                   |
|                     | Machine adaption:                         | Centering key b 20    |
|                     | Tool adaption:                            | Sq. 3/4" (19,05mm)    |
|                     |   | Sq. 3/4" (19,05mm)    |
|                     |   | Sq. 3/4" (19,05mm)    |
|                     |   | Sq. 3/4" (19,05mm)    |
|                     | Coolant:                                  | EXT                   |
| <b>8 251 14 028</b> | <b>Combi multiple holder 3x sq. 3/4"</b>  |                       |
|                     | Weight [kg]:                              | 3.760                 |
|                     | Shank type:                               | BMT                   |
|                     | Machine adaption:                         | Centering key b 20    |
|                     | Tool adaption:                            | Sq. 3/4" (19,05mm)    |
|                     |   | Sq. 3/4" (19,05mm)    |
|                     | Coolant:                                  | EXT                   |
| <b>8 251 14 033</b> | <b>Combi multiple holder 3x sq. 20</b>    |                       |
|                     | Weight [kg]:                              | 3.740                 |
|                     | Shank type:                               | BMT                   |
|                     | Machine adaption:                         | Centering key b 20    |
|                     | Tool adaption:                            | Sq. 20                |
|                     |   | Sq. 20                |
|                     | Coolant:                                  | EXT                   |
| <b>8 251 14 074</b> | <b>Combi multiple holder 6x sq. 20 IC</b> |                       |
|                     | Weight [kg]:                              | 6.160                 |
|                     | Notation:                                 | 180° reversible       |
|                     | Employment for:                           | Main- and sub spindle |
|                     | Shank type:                               | BMT                   |
|                     | Machine adaption:                         | Centering key b 20    |
|                     | Tool adaption:                            | Sq. 20                |
|                     |   | Sq. 20                |
|                     |   | Sq. 20                |
|                     |   | Sq. 20                |
|                     | Coolant:                                  | IC/Ext                |
|                     | Pressure max [bar]:                       | 100                   |

| Part-#  | Name  |   |
|---|---|---|
|   | Please note:  | Key rail  |
| <b>8 251 14 075</b>   | <b>Combi multiple holder 3x sq. 20 IC</b>   |   |
|    | Shank type:<br>Machine adaption:<br>Tool adaption:<br><br>Coolant:<br>Pressure max [bar]:<br>Please note:   | BMT<br>Centering key b 20<br>Sq. 20<br>Sq. 20<br>IC/Ext<br>100<br>Key rail  |
| <b>8 251 14 098</b>   | <b>Combi multiple holder 3x sq. 20 IC</b>   |   |
|    | Weight [kg]:<br>Shank type:<br>Machine adaption:<br>Tool adaption:<br><br>Coolant:<br>Pressure max [bar]:<br>Please note:                                 | 3.480<br>BMT<br>Centering key b 20<br>Sq. 20<br>Sq. 20<br>IC/Ext<br>100<br>Key rail   |
| <b>8 251 14 100</b>   | <b>Combi double turning holder sq. 20 IC</b>  |   |
|  | Weight [kg]:<br>Notation:<br>Employment for:<br>Shank type:<br>Machine adaption:<br>Tool adaption:<br><br>Coolant:<br>Pressure max [bar]:<br>Please note: | 5.300<br>180° reversible<br>Main- and sub spindle<br>BMT<br>Centering key b 20<br>Sq. 20<br>Sq. 20<br>Sq. 20<br>Sq. 20<br>IC/Ext<br>100<br>Key rail                             |
| <b>8 251 15 031</b>   | <b>Multiple tool holder C 3 IC</b>  |   |
|   | Weight [kg]:<br>Employment for:<br>Version:<br>Shank type:<br>Machine adaption:<br>Tool adaption:<br><br>Coolant:<br>Please note:<br>Offset [mm]:         | 5.930<br>Main- and sub spindle<br>right<br>BMT<br>Centering key b 20<br>heimatec Capto(TM) C 3<br>heimatec Capto(TM) C 3<br>IC<br>Check applicability; note tool length!<br>±60 |
| <b>8 251 15 048</b>   | <b>Combi double turning holder sq. 25 IC</b>  |   |
|  | Notation:<br>Employment for:<br>Shank type:<br>Machine adaption:<br>Tool adaption:  | 180° reversible<br>Main- and sub spindle<br>BMT<br>Centering key b 20<br>Sq. 25<br>Sq. 25<br>Sq. 25<br>Sq. 25   |

Nakamura  
Super NTJ-unterer Revolver

| Part-#              | Name                               |  |
|---------------------|------------------------------------|--|
|                     | Coolant:                           | IC/Ext   |
|                     | Pressure max [bar]:                | 100  |
|                     | Please note:                       | Key rail   |
| <b>8 251 16 008</b> | <b>Multiple tool holder C 4 IC</b> |  |
|                     | Weight [kg]:                       | 6.420  |
|                     | Employment for:                    | Main- and sub spindle                                  |
|                     | Version:                           | right  |
|                     | Shank type:                        | BMT  |
|                     | Machine adaption:                  | Centering key b 20                                     |
|                     | Tool adaption:                     | heimatec Capto(TM) C 4<br>heimatec Capto(TM) C 4       |
|                     | Coolant:                           | IC   |
|                     | Please note:                       | Check applicability; note tool length!                 |
|                     | Offset [mm]:                       | ±64  |
| <b>8 253 16 001</b> | <b>Double tool holder HT 4</b>     |  |
|                     | Weight [kg]:                       | 3.740  |
|                     | Version:                           | Special  |
|                     | Shank type:                        | BMT  |
|                     | Machine adaption:                  | Centering key b 20                                     |
|                     | Tool adaption:                     | HT 4   |
|                     | Coolant:                           | IC/Ext   |
|                     | Center distance [mm]:              | 47,5/92,5  |
| <b>8 253 16 038</b> | <b>Multiple tool holder C 4 IC</b> |  |
|                     | Weight [kg]:                       | 6.060  |
|                     | Version:                           | right  |
|                     | Shank type:                        | BMT  |
|                     | Machine adaption:                  | Centering key b 20                                     |
|                     | Tool adaption:                     | heimatec Capto(TM) C 4<br>heimatec Capto(TM) C 4 - 15° |
|                     | Coolant:                           | IC   |
|                     | Please note:                       | Use necessarily check; note tool length                |
|                     | Center distance [mm]:              | 75   |
| <b>8 253 16 039</b> | <b>Multiple tool holder C 4 IC</b> |  |
|                     | Weight [kg]:                       | 4.910  |
|                     | Version:                           | offset; right  |
|                     | Shank type:                        | BMT  |
|                     | Machine adaption:                  | Centering key b 20                                     |
|                     | Tool adaption:                     | heimatec Capto(TM) C 4<br>heimatec Capto(TM) C 4 - 15° |
|                     | Coolant:                           | IC   |
|                     | Please note:                       | Check applicability; note tool length!                 |
|                     | Center distance [mm]:              | 75   |
| <b>8 253 16 040</b> | <b>Multiple tool holder C 4 IC</b> |  |
|                     | Weight [kg]:                       | 6.070  |
|                     | Version:                           | right  |
|                     | Shank type:                        | BMT  |
|                     | Machine adaption:                  | Centering key b 20                                     |
|                     | Tool adaption:                     | heimatec Capto(TM) C 4<br>heimatec Capto(TM) C 4 - 15° |
|                     | Coolant:                           | IC   |
|                     | Please note:                       | Check applicability; note tool length!                 |
|                     | Center distance [mm]:              | 75   |

Nakamura  
Super NTJ-unterer Revolver

| Part-#              | Name                                      |  |
|---------------------|---|--|
| <b>8 253 16 041</b> | <b>Multiple tool holder C 4 IC</b>        |  |
|                     | Weight [kg]:                              | 4.900  |
|                     | Version:                                  | offset; right  |
|                     | Shank type:                               | BMT  |
|                     | Machine adaption:                         | Centering key b 20                                     |
|                     | Tool adaption:                            | heimatec Capto(TM) C 4<br>heimatec Capto(TM) C 4 - 15° |
|                     | Coolant:                                  | IC   |
|                     | Please note:                              | Check applicability; note tool length!                 |
|                     | Center distance [mm]:                     | 75   |
| <b>8 253 17 016</b> | <b>Double boring bar holder Ø 25</b>      |  |
|                     | Weight [kg]:                              | 2.660  |
|                     | Notation:                                 | 180° reversible  |
|                     | Shank type:                               | BMT  |
|                     | Machine adaption:                         | Centering key b 20                                     |
|                     | Tool adaption:                            | Ø 25<br>Ø 25   |
|                     | Coolant:                                  | IC/Ext   |
|                     | Center distance [mm]:                     | 47,5/82,5  |
| <b>8 253 17 017</b> | <b>Multiple boring bar holder 3x Ø 25</b> |  |
|                     | Weight [kg]:                              | 4.900  |
|                     | Notation:                                 | 180° reversible  |
|                     | Employment for:                           | Main- and sub spindle                                  |
|                     | Shank type:                               | BMT  |
|                     | Machine adaption:                         | Centering key b 20                                     |
|                     | Tool adaption:                            | Ø 25<br>Ø 25   |
|                     | Coolant:                                  | IC/Ext   |
|                     | Center distance [mm]:                     | 47,5/82,5  |
| <b>8 253 17 034</b> | <b>Double boring bar holder Ø 1"</b>      |  |
|                     | Weight [kg]:                              | 2.480  |
|                     | Shank type:                               | BMT  |
|                     | Machine adaption:                         | Centering key b 20                                     |
|                     | Tool adaption:                            | Ø 1" (25,4mm)  |
|                     | Coolant:                                  | IC/Ext   |
|                     | Center distance [mm]:                     | 47,5/82,5  |
| <b>8 253 17 047</b> | <b>Multiple boring bar holder 3x Ø 1"</b> |  |
|                     | Weight [kg]:                              | 4.890  |
|                     | Notation:                                 | 180° reversible  |
|                     | Employment for:                           | Main- and sub spindle                                  |
|                     | Shank type:                               | BMT  |
|                     | Machine adaption:                         | Centering key b 20                                     |
|                     | Tool adaption:                            | Ø 1" (25,4mm)<br>Ø 1" (25,4mm)                         |
|                     | Coolant:                                  | IC/Ext   |
|                     | Center distance [mm]:                     | 47,5/82,5  |
| <b>8 253 17 048</b> | <b>Multiple boring bar holder 2x Ø 25</b> |  |
|                     | Weight [kg]:                              | 5.930  |
|                     | Employment for:                           | Main spindle   |
|                     | Version:                                  | long; special  |
|                     | Shank type:                               | BMT  |
|                     | Machine adaption:                         | Centering key b 20                                     |
|                     | Tool adaption:                            | Ø 25   |

# Nakamura

## Super NTJ-unterer Revolver

| Part-#              | Name                                     |                                      |
|---------------------|--|--------------------------------------|
|                     | Coolant:                                 | Ø 25 - 15°                           |
|                     | Center distance [mm]:                    | IC/Ext<br>75                         |
| <b>8 254 14 002</b> | <b>Multiple facing holder 3x sq. 20</b>  |                                      |
|                     | Weight [kg]:                             | 5.860                                |
|                     | Employment for:                          | Main spindle                         |
|                     | Version:                                 | long; special                        |
|                     | Shank type:                              | BMT                                  |
|                     | Machine adaption:                        | Centering key b 20                   |
|                     | Tool adaption:                           | Sq. 20<br>Sq. 20                     |
|                     | Coolant:                                 | EXT                                  |
|                     | Center distance [mm]:                    | 70                                   |
| <b>8 259 12 010</b> | <b>Multiple turning holder 2x sq. 20</b> |                                      |
|                     | Weight [kg]:                             | 2.890                                |
|                     | Notation:                                | 180° reversible                      |
|                     | Version:                                 | Y-axes offset                        |
|                     | Shank type:                              | BMT                                  |
|                     | Machine adaption:                        | Centering key b 20                   |
|                     | Tool adaption:                           | Sq. 20<br>Sq. 20                     |
|                     | Coolant:                                 | EXT                                  |
| <b>8 259 15 001</b> | <b>Multiple holder C 3 and sq. 20</b>    |                                      |
|                     | Weight [kg]:                             | 3.960                                |
|                     | Notation:                                | 180° reversible                      |
|                     | Shank type:                              | BMT                                  |
|                     | Machine adaption:                        | Centering key b 20                   |
|                     | Tool adaption:                           | Sq. 20<br>heimatec Capto(TM) C 3     |
|                     | Coolant:                                 | IC/Ext                               |
|                     | Center distance [mm]:                    | 55                                   |
| <b>8 259 15 002</b> | <b>Multiple holder C 3 and sq. 20</b>    |                                      |
|                     | Employment for:                          | Main- and sub spindle                |
|                     | Shank type:                              | BMT                                  |
|                     | Machine adaption:                        | Centering key b 20                   |
|                     | Tool adaption:                           | Sq. 20<br>Sq. 20<br>Sq. 20<br>Sq. 20 |
|                     | Coolant:                                 | IC/Ext                               |
|                     | Please note:                             | note machining direction for C 3!    |
|                     | Center distance [mm]:                    | 82,5                                 |
| <b>8 259 15 003</b> | <b>Multiple holder C 3 and sq. 20</b>    |                                      |
|                     | Weight [kg]:                             | 7.040                                |
|                     | Employment for:                          | Main- and sub spindle                |
|                     | Shank type:                              | BMT                                  |
|                     | Machine adaption:                        | Centering key b 20                   |
|                     | Tool adaption:                           | Sq. 20<br>Sq. 20<br>Sq. 20<br>Sq. 20 |
|                     | Coolant:                                 | IC/Ext                               |
|                     | Please note:                             | note machining direction for C 3!    |

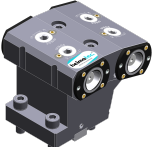
| Part-#  | Name                                    |  |
|---|---|--|
|   | Center distance [mm]:                   | 82,5   |
| <b>8 259 15 013</b>   | <b>Multiple tool holder C 3 IC</b>      |  |
|  | Weight [kg]:                            | 6.420  |
|   | Employment for:                         | Main- and sub spindle  |
|   | Version:                                | right  |
|   | Shank type:                             | BMT  |
|   | Machine adaption:                       | Centering key b 20   |
|   | Tool adaption:                          | heimatec Capto(TM) C 3<br>heimatec Capto(TM) C 3               |
|   | Coolant:                                | IC   |
|   | Please note:                            | Check applicability; note tool length!                         |
|   | Center distance [mm]:                   | 82,5   |
| <b>8 259 15 014</b>   | <b>Multiple tool holder C 3 IC</b>      |  |
|   | Weight [kg]:                            | 6.470  |
|   | Employment for:                         | Main- and sub spindle  |
|   | Version:                                | offset; right  |
|   | Shank type:                             | BMT  |
|   | Machine adaption:                       | Centering key b 20   |
|   | Tool adaption:                          | heimatec Capto(TM) C 3<br>heimatec Capto(TM) C 3               |
|   | Coolant:                                | IC   |
|   | Please note:                            | Check applicability; note tool length!                         |
|   | Center distance [mm]:                   | 82,5   |
| <b>8 259 16 007</b>   | <b>Multiple tool holder C 4 IC</b>      |  |
|   | Weight [kg]:                            | 9.320  |
|   | Employment for:                         | Main- and sub spindle  |
|   | Version:                                | right  |
|   | Shank type:                             | BMT  |
|   | Machine adaption:                       | Centering key b 20   |
|   | Tool adaption:                          | heimatec Capto(TM) C 4<br>heimatec Capto(TM) C 4               |
|   | Coolant:                                | IC   |
|   | Please note:                            | Check applicability; note tool length!                         |
|   | Center distance [mm]:                   | 75   |
| <b>8 259 17 001</b>   | <b>Multiple holder 2x C 3 and Ø 25</b>  |  |
|   | Weight [kg]:                            | 5.340  |
|   | Employment for:                         | Main- and sub spindle  |
|   | Shank type:                             | BMT  |
|   | Machine adaption:                       | Centering key b 20   |
|   | Tool adaption:                          | heimatec Capto(TM) C 3<br>heimatec Capto(TM) C 3 - 15°<br>Ø 25 |
|   | Coolant:                                | IC/Ext   |
|   | Please note:                            | note machining direction for C 3!                              |
|   | Center distance [mm]:                   | 47,5/82,5  |
| <b>8 259 19 002</b>   | <b>Multiple holder ER 25 and sq. 20</b> |  |
|   | Weight [kg]:                            | 3.620  |
|   | Notation:                               | 180° reversible  |
|   | Shank type:                             | BMT  |
|   | Machine adaption:                       | Centering key b 20   |
|   | Tool adaption:                          | Sq. 20<br>ER 25  |

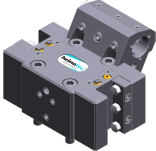
| Part-#   | Name                                     |                               |
|--|--|-------------------------------|
|  | Coolant:                                 | IC/Ext                        |
|  | Center distance [mm]:                    | 55                            |
| <b>8 259 19 004</b>  | <b>Multiple holder Ø 25 and sq. 20</b>   |                               |
|  | Weight [kg]:                             | 6.500                         |
|  | Employment for:                          | Main- and sub spindle         |
|  | Shank type:                              | BMT                           |
|  | Machine adaption:                        | Centering key b 20            |
|  | Tool adaption:                           | Sq. 20                        |
|  |  | Sq. 20                        |
|  |  | Sq. 20                        |
|  |  | Sq. 20                        |
|  | Coolant:                                 | IC/Ext                        |
|  | Center distance [mm]:                    | 82,5                          |
| <b>8 259 19 012</b>  | <b>Multiple holder Ø 1" and sq. 3/4"</b> |                               |
|  | Weight [kg]:                             | 6.610                         |
|  | Employment for:                          | Main- and sub spindle         |
|  | Shank type:                              | BMT                           |
|  | Machine adaption:                        | Centering key b 20            |
|  | Tool adaption:                           | Sq. 3/4" (19,05mm)            |
|  |  | Sq. 3/4" (19,05mm)            |
|  |  | Sq. 3/4" (19,05mm)            |
|  |  | Sq. 3/4" (19,05mm)            |
|  | Coolant:                                 | IC/Ext                        |
|  | Pressure max [bar]:                      | 140                           |
|  | Center distance [mm]:                    | 82,5                          |
| <b>8 261 18 003</b>  | <b>Tool holder for centering insert</b>  |                               |
|  | Weight [kg]:                             | 5.960                         |
|  | Notation:                                | 180° reversible               |
|  | Shank type:                              | BMT                           |
|  | Machine adaption:                        | Centering key b 20            |
|  | Tool adaption:                           | Ø 32                          |
|  | Coolant:                                 | EXT                           |
|  | Please note:                             | Price without centering point |
|  | Center distance [mm]:                    | 55 or 75                      |
| <b>8 261 18 004</b>  | <b>Tool holder for centering insert</b>  |                               |
|  | Notation:                                | 180° reversible               |
|  | Version:                                 | Special                       |
|  | Shank type:                              | BMT                           |
|  | Machine adaption:                        | Centering key b 20            |
|  | Tool adaption:                           | Ø 34                          |
|  | Coolant:                                 | EXT                           |
|  | Please note:                             | Price without centering point |
|  | Center distance [mm]:                    | 55                            |
| <b>8 262 19 002</b>  | <b>Stock stop Ø 54 offset</b>            |                               |
|  | Weight [kg]:                             | 2.980                         |
|  | Notation:                                | rotating                      |
|  | Shank type:                              | BMT                           |
|  | Machine adaption:                        | Centering key b 20            |
|  | Coolant:                                 | no                            |
|  | Please note:                             | Lenght adjustable             |
|  | Center distance [mm]:                    | 75                            |

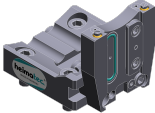
| Part-#  | Name  |                                 |
|---|---|---------------------------------|
| <b>8 263 19 012</b>   | <b>Tool holder with rotating centering point</b>  |                                 |
|   | Weight [kg]:                                      | 4.340                           |
|   | Notation:   | 180° reversible                 |
|   | Version:  | Special                         |
|   | Shank type:                                       | BMT                             |
|   | Machine adaption:                                 | Centering key b 20              |
|   | Rotation max [1/min]:                             | 6000                            |
|   | Coolant:  | EXT                             |
|   | Please note:                                      | Taper roller bearings           |
|   | Center distance [mm]:                             | 75                              |
| <b>8 263 19 013</b>   | <b>Tool holder with rotating centering point</b>  |                                 |
|   | Weight [kg]:                                      | 4.290                           |
|   | Notation:   | 180° reversible                 |
|   | Version:  | Special                         |
|   | Shank type:                                       | BMT                             |
|   | Machine adaption:                                 | Centering key b 20              |
|   | Rotation max [1/min]:                             | 6000                            |
|   | Coolant:  | EXT                             |
|   | Please note:                                      | Taper roller bearings           |
|   | Center distance [mm]:                             | 75                              |
| <b>8 268 14 000</b>   | <b>Support Y-axes adjustable</b>                  |                                 |
|   | Weight [kg]:                                      | 3.180                           |
|   | Version:  | Special                         |
|   | Shank type:                                       | BMT                             |
|   | Machine adaption:                                 | Centering key b 20              |
|   | Center distance [mm]:                             | 90                              |
| <b>8 268 18 000</b>   | <b>Support Y-axes adjustable</b>                  |                                 |
|   | Version:  | Special                         |
|   | Shank type:                                       | BMT                             |
|   | Machine adaption:                                 | Centering key b 20              |
|   | Tool adaption:                                    | Ø 38                            |
|   | Coolant:  | no                              |
|   | Center distance [mm]:                             | 75                              |
| <b>8 320 12 010</b>   | <b>Cut-off holder, height adjustable SH 26 IC</b> |                                 |
|  | Weight [kg]:                                      | 1.680                           |
|   | Notation:   | 180° reversible                 |
|   | Shank type:                                       | BMT                             |
|   | Machine adaption:                                 | Centering key b 20              |
|   | Tool adaption:                                    | Clampshaft SH 26                |
|   | Coolant:  | IC/Ext                          |
|   | Pressure max [bar]:                               | 70                              |
| <b>8 320 12 020</b>   | <b>Cut-off holder, height adjustable SH 26 IC</b> |                                 |
|   | Notation:   | 180° reversible                 |
|   | Shank type:                                       | BMT                             |
|   | Machine adaption:                                 | Centering key b 20              |
|   | Tool adaption:                                    | Clampshaft SH 26                |
|   | Coolant:  | IC/Ext                          |
|   | Pressure max [bar]:                               | 70                              |
|   | Please note:                                      | with offset cut-off tool holder |

Nakamura  
Super NTJ-unterer Revolver

| Part-#  | Name  |                                  |
|---|---|----------------------------------|
| <b>8 320 13 002</b>   | <b>Cut-off holder, height adjustable SH 32 IC</b> |                                  |
|    | Weight [kg]:                                      | 1.570                            |
|   | Notation:   | 180° reversible                  |
|   | Shank type:                                       | BMT                              |
|   | Machine adaption:                                 | Centering key b 20               |
|   | Tool adaption:                                    | Clampshaft SH 32                 |
|   | Coolant:  | IC/Ext                           |
|   | Pressure max [bar]:                               | 70                               |
| <b>8 320 13 010</b>   | <b>Cut-off holder, height adjustable SH 32 IC</b> |                                  |
|    | Weight [kg]:                                      | 1.730                            |
|   | Notation:   | 180° reversible                  |
|   | Shank type:                                       | BMT                              |
|   | Machine adaption:                                 | Centering key b 20               |
|   | Tool adaption:                                    | Clampshaft SH 32                 |
|   | Coolant:  | IC/Ext                           |
|   | Pressure max [bar]:                               | 70                               |
|   | Please note:                                      | Clampshaft internal              |
| <b>8 320 13 015</b>   | <b>Cut-off holder, height adjustable SH 32 IC</b> |                                  |
|   | Weight [kg]:                                      | 1.830                            |
|   | Notation:   | 180° reversible                  |
|   | Shank type:                                       | BMT                              |
|   | Machine adaption:                                 | Centering key b 20               |
|   | Tool adaption:                                    | Clampshaft SH 32                 |
|   | Coolant:  | IC/Ext                           |
|   | Pressure max [bar]:                               | 70                               |
|   | Please note:                                      | with offset cut-off tool holder  |
| <b>8 782 16 001</b>   | <b>Spacer plate 20mm</b>                          |                                  |
|   | Shank type:                                       | BMT                              |
|   | Machine adaption:                                 | Centering key b 20               |
|   | Tool adaption:                                    | Centering key slot b 20          |
|   | Coolant:  | EXT                              |
|   | Please note:                                      | Plate without fastening screws ! |
| <b>8 782 16 003</b>   | <b>Spacer plate 25mm</b>                          |                                  |
|  | Shank type:                                       | BMT                              |
|   | Machine adaption:                                 | Centering key b 20               |
|   | Tool adaption:                                    | Centering key slot b 20          |
|   | Coolant:  | EXT                              |
|   | Please note:                                      | Plate without fastening screws ! |

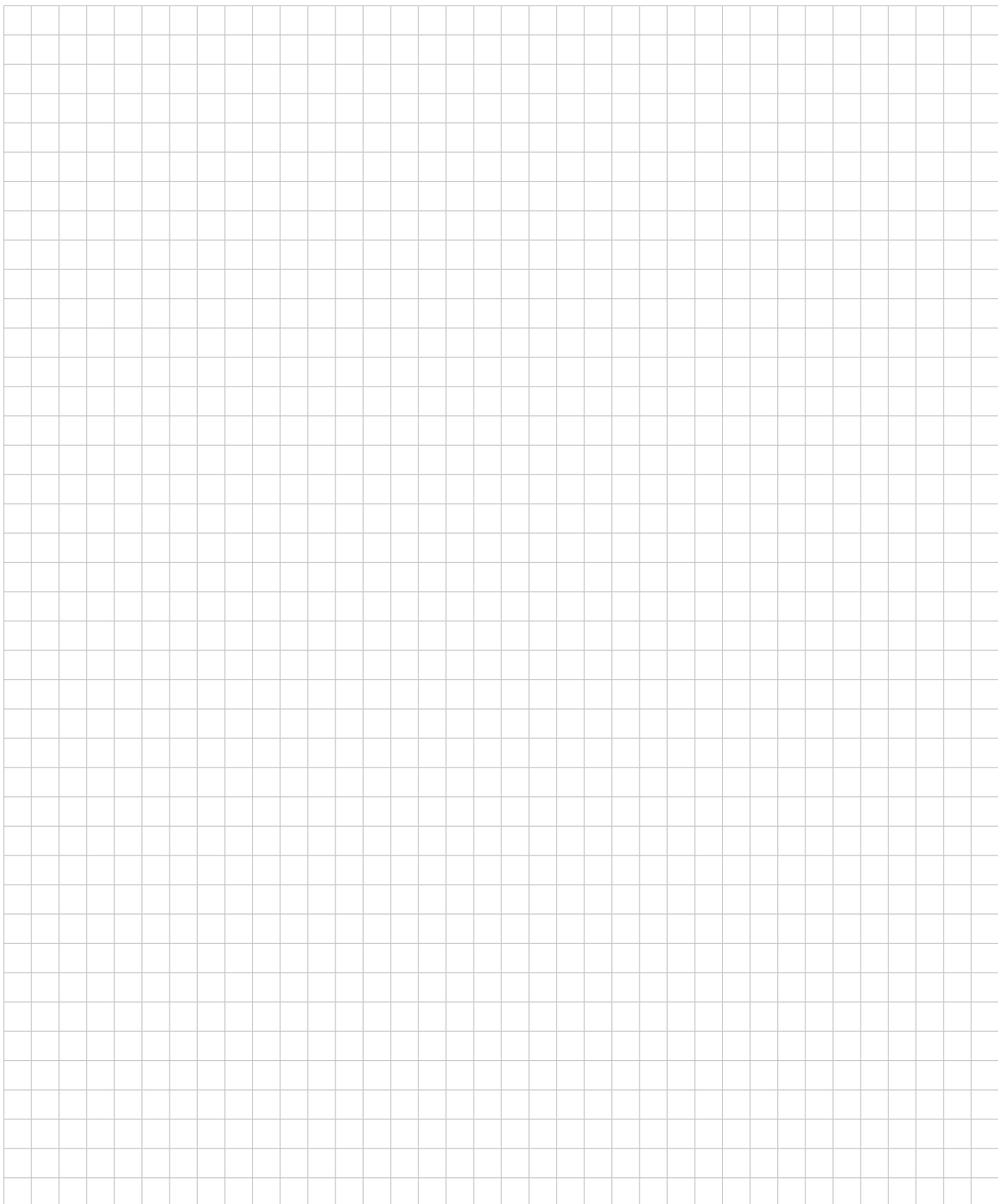

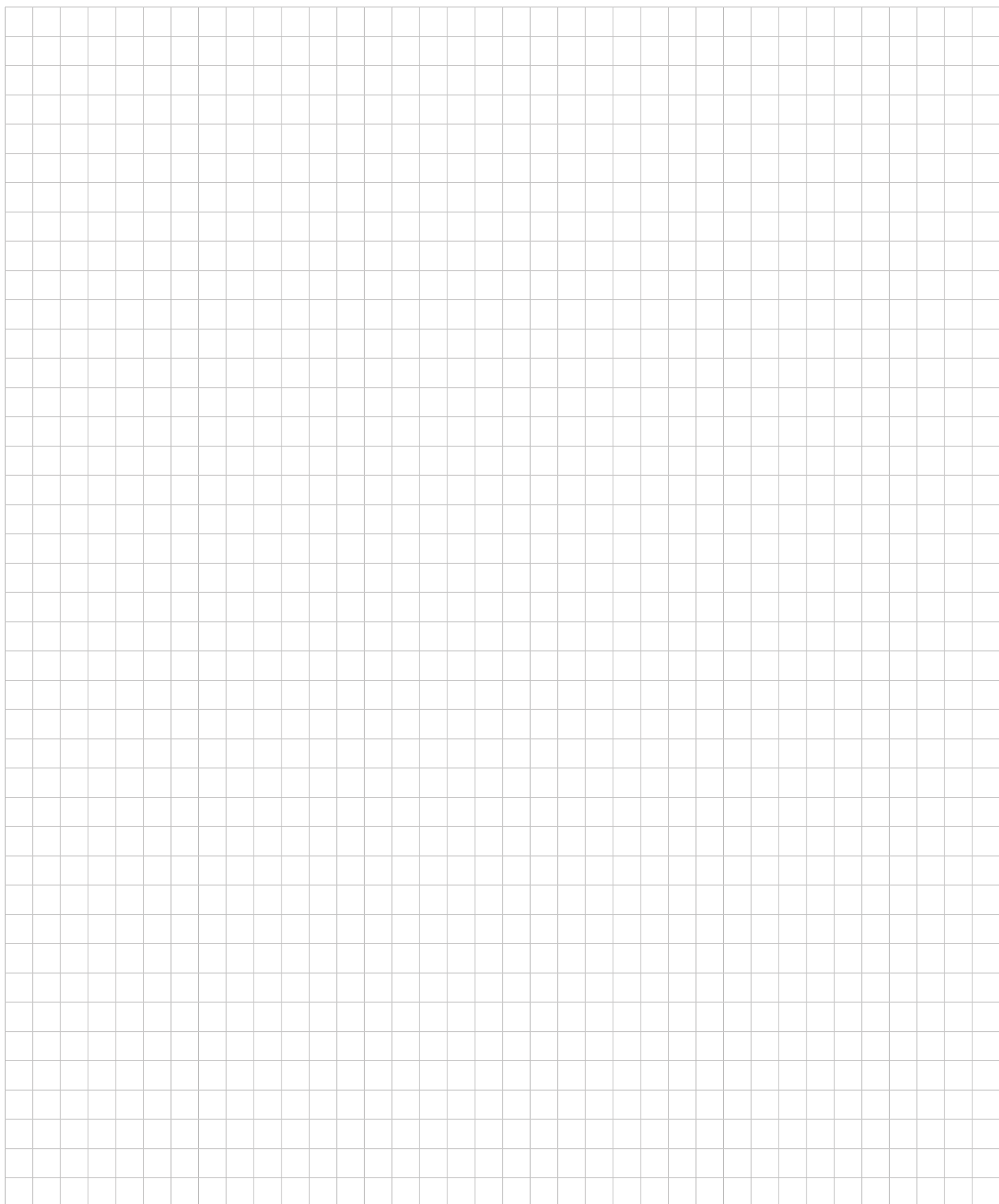

## heimatec.u-tec®

heimatec.com

Products / Tool change systems /  
u-tec® Tool-changing system



versions see catalog

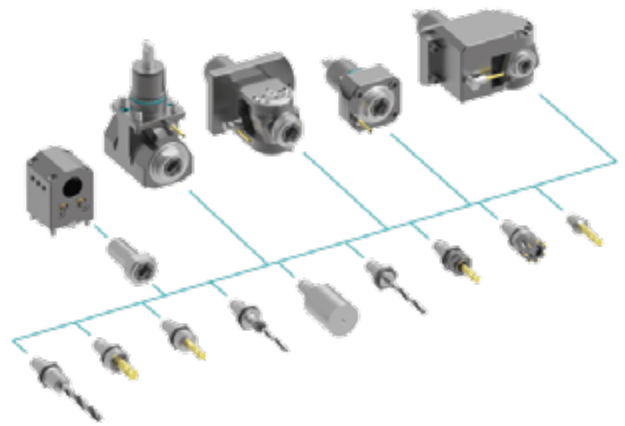

## heimatec.easy-quick

heimatec.com

Products / Tool change systems /  
easy-quick HT quick-changing system



versions see catalog

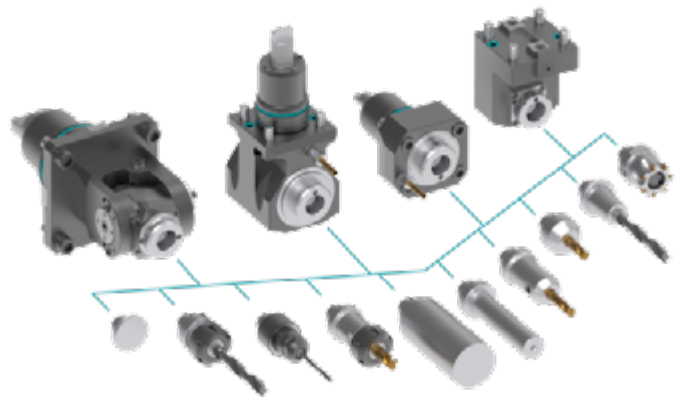

## heimatec.Capto™

heimatec.com

Products / Tool change systems /  
heimatec.Capto™ quick-changing system



versions see catalog

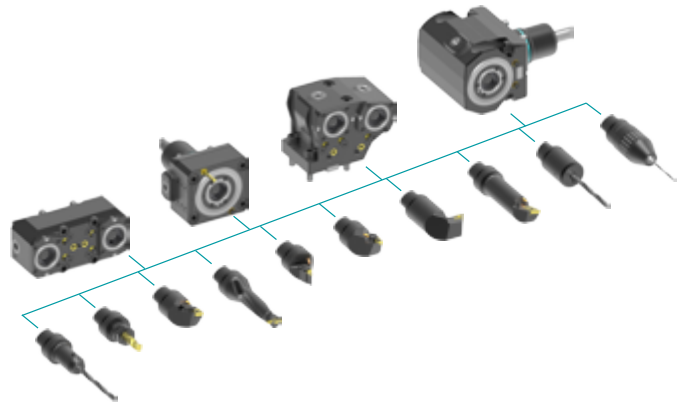

## heimatec.accessories

heimatec.com

Products / Accessories



versions see catalog





● heimatec overseas branches

○ global representations of heimatec

**heimatec**<sup>®</sup>

**heimatec GmbH**  
Präzisionswerkzeuge  
Carl-Benz-Str. 4  
77871 Renchen  
Germany

T +49 7843 9466 0  
[www.heimatec.com](http://www.heimatec.com)  
[info@heimatec.com](mailto:info@heimatec.com)

Please find the contact details of our worldwide trading partners on our website:  
<https://heimatec.com/business-partners>