

Nakamura
TMC-300 M



High-tech from heimatec - heimatec - Tools and systems for productive turning and milling

heimatec belongs to the international technology and quality leaders for precision tools and specializes in the development and production of high-precision static and live tools for all CNC lathes, CNC turn-/mill machines and CNC machining centers.

The range of products* spans from static BMT and VDI tool holders, live tools up to highly complex customer-specific individual solutions. heimatec, headquartered in Renchen, has a own subsidiary in Asia and India and numerous representatives as well as trading partners all over the world.

*OUR PRODCUTS

Static tool holders

Live tool units

Precision tools

Tools for turning and machining centres

Tools for swiss type lathes

Tool changing and uick-change systems

Tool systems for gear production

Digital tool management

This catalogue, including all its parts, is protected by copyright. Any use outside the restricted limitations of the Copyright Act without the consent of heimatec is inadmissible and liable to prosecution. This applies in particular to duplication, translation, microfilming and storage and processing in electronic systems.



heimatec GmbH reserves the right to make technical changes at any time without giving prior notice. This applies in particular to adjustments at any time to meet new or changed international standards, or in case of further developments of our products or manufacturing processes.

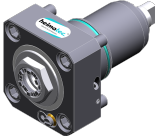

The current version of our General Terms and Conditions can be found on our website.

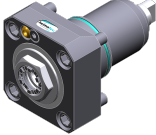
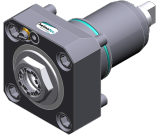
Part-#	Name	
8 010 64 003	Axial drilling and milling head Weldon 12 IC	
	Tool drive:	Flat (~DIN 1809)
	Shank size [mm]:	65.00
	Shank type:	BMT
	Tool adaption:	Weldon (DIN 1835 b) 12
	Gear ratio [i]:	1:1
	Torque max [Nm]:	50
	Rotation max [1/min]:	6000
	Rotating direction:	same
	Coolant:	IC/Ext
	Pressure max [bar]:	25
8 010 64 005	Axial drilling and milling head Weldon 12	
	Tool drive:	Flat (~DIN 1809)
	Shank size [mm]:	65.00
	Shank type:	BMT
	Tool adaption:	Weldon (DIN 1835 b) 12
	Gear ratio [i]:	1:1
	Torque max [Nm]:	50
	Rotation max [1/min]:	6000
	Rotating direction:	same
	Coolant:	EXT
8 010 64 006	Axial drilling and milling head Weldon 14 IC	
	Tool drive:	Flat (~DIN 1809)
	Shank size [mm]:	65.00
	Shank type:	BMT
	Tool adaption:	Weldon (DIN 1835 b) 14
	Gear ratio [i]:	1:1
	Torque max [Nm]:	50
	Rotation max [1/min]:	6000
	Rotating direction:	same
	Coolant:	IC/Ext
8 010 65 005	Axial drilling and milling head Weldon 16	
	Weight [kg]:	2.920
	Tool drive:	Flat (~DIN 1809)
	Shank size [mm]:	65.00
	Shank type:	BMT
	Tool adaption:	Weldon (DIN 1835 b) 16
	Gear ratio [i]:	1:1
	Torque max [Nm]:	50
	Rotation max [1/min]:	6000
	Rotating direction:	same
	Coolant:	EXT
8 010 65 006	Axial drilling and milling head Weldon 16 IC	
	Tool drive:	Flat (~DIN 1809)
	Shank size [mm]:	65.00
	Shank type:	BMT
	Tool adaption:	Weldon (DIN 1835 b) 16
	Gear ratio [i]:	1:1
	Torque max [Nm]:	50
	Rotation max [1/min]:	6000
	Rotating direction:	same
	Coolant:	IC/Ext
	Pressure max [bar]:	25

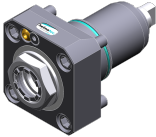
Part-#	Name	
8 010 65 017	Axial drilling and milling head ER 25 AX UT IC	
	Weight [kg]:	2.800
	Tool drive:	Flat (~DIN 1809)
	Shank size [mm]:	65.00
	Shank type:	BMT
	Tool adaption:	ER 25 A - u-tec
	Gear ratio [i]:	1:1
	Torque max [Nm]:	50
	Rotation max [1/min]:	6000
	Rotating direction:	same
	Coolant:	IC/Ext
	Pressure max [bar]:	25
	Please note:	stronger bearing
8 010 65 020	Axial drilling and milling head ER 25 AX UT IC	
	Weight [kg]:	2.700
	Tool drive:	Flat (~DIN 1809)
	Shank size [mm]:	65.00
	Shank type:	BMT
	Tool adaption:	ER 25 A - u-tec
	Gear ratio [i]:	1:1
	Torque max [Nm]:	50
	Rotation max [1/min]:	6000
	Rotating direction:	same
	Coolant:	IC/Ext
	Pressure max [bar]:	25
8 010 65 021	Axial drilling and milling head ER 25 AX UT	
	Weight [kg]:	2.670
	Tool drive:	Flat (~DIN 1809)
	Shank size [mm]:	65.00
	Shank type:	BMT
	Tool adaption:	ER 25 A - u-tec
	Gear ratio [i]:	1:1
	Torque max [Nm]:	50
	Rotation max [1/min]:	6000
	Rotating direction:	same
	Coolant:	EXT
8 010 65 022	Axial milling and drill holder ER 25 AX UT IC	
	Tool drive:	Flat (~DIN 1809)
	Shank size [mm]:	65.00
	Shank type:	BMT
	Tool adaption:	ER 25 A - u-tec
	Gear ratio [i]:	1:1
	Torque max [Nm]:	50
	Rotation max [1/min]:	5000
	Rotating direction:	same
	Coolant:	IC/Ext
	Pressure max [bar]:	100
	Please note:	Combi bearing; dryrun possible

Part-#	Name	
	8 010 65 023	Axial milling and drill holder ER 25 AX UT
		Weight [kg]: 3.950 Tool drive: Flat (~DIN 1809) Shank size [mm]: 65.00 Shank type: BMT Tool adaption: ER 25 A - u-tec Gear ratio [i]: 1:1 Torque max [Nm]: 50 Rotation max [1/min]: 5000 Rotating direction: same Coolant: EXT Please note: Combi bearing
	8 010 65 038	Axial drilling and milling head ER 25 AX UT IC
		Tool drive: Flat (~DIN 1809) Shank size [mm]: 65.00 Shank type: BMT Tool adaption: ER 25 A - u-tec Gear ratio [i]: 1:1 Torque max [Nm]: 50 Rotation max [1/min]: 5000 Rotating direction: same Coolant: IC/Ext Pressure max [bar]: 100 Please note: Dryrun possible
	8 010 66 002	Axial drilling and milling head ER 32 IC
		Weight [kg]: 2.920 Tool drive: Flat (~DIN 1809) Shank size [mm]: 65.00 Shank type: BMT Tool adaption: ER 32 Gear ratio [i]: 1:1 Torque max [Nm]: 50 Rotation max [1/min]: 6000 Rotating direction: same Coolant: IC/Ext Pressure max [bar]: 25
	8 010 66 003	Axial drilling and milling head ER 32
		Weight [kg]: 2.880 Tool drive: Flat (~DIN 1809) Shank size [mm]: 65.00 Shank type: BMT Tool adaption: ER 32 Gear ratio [i]: 1:1 Torque max [Nm]: 50 Rotation max [1/min]: 6000 Rotating direction: same Coolant: EXT

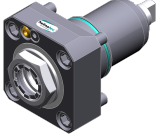
Part-#	Name	
8 010 66 017	Axial drilling and milling head HT 4	
	Weight [kg]:	2.860
	Tool drive:	Flat (~DIN 1809)
	Shank size [mm]:	65.00
	Shank type:	BMT
	Tool adaption:	HT 4
	Gear ratio [i]:	1:1
	Torque max [Nm]:	50
	Rotation max [1/min]:	6000
	Rotating direction:	same
	Coolant:	EXT
	Please note:	stronger bearing
8 010 66 043	Axial drilling and milling head ER 32 IC	
	Weight [kg]:	3.000
	Tool drive:	Flat (~DIN 1809)
	Shank size [mm]:	65.00
	Shank type:	BMT
	Tool adaption:	ER 32
	Gear ratio [i]:	1:1
	Torque max [Nm]:	50
	Rotation max [1/min]:	6000
	Rotating direction:	same
	Coolant:	IC/Ext
	Pressure max [bar]:	25
	Please note:	stronger bearing
8 010 66 050	Axial milling and drill holder ER 32 AX UT	
	Weight [kg]:	3.920
	Tool drive:	Flat (~DIN 1809)
	Shank size [mm]:	65.00
	Shank type:	BMT
	Tool adaption:	ER 32 A - u-tec
	Gear ratio [i]:	1:1
	Torque max [Nm]:	50
	Rotation max [1/min]:	5000
	Rotating direction:	same
	Coolant:	EXT
	Please note:	Combi bearing
8 010 66 067	Axial milling and drill holder ER 32 AX UT IC	
	Weight [kg]:	4.030
	Tool drive:	Flat (~DIN 1809)
	Shank size [mm]:	65.00
	Shank type:	BMT
	Tool adaption:	ER 32 A - u-tec
	Gear ratio [i]:	1:1
	Torque max [Nm]:	50
	Rotation max [1/min]:	5000
	Rotating direction:	same
	Coolant:	IC/Ext
	Pressure max [bar]:	100
	Please note:	Combi bearing; Trockenauf possible

Part-#	Name	
	8 010 66 126	Axial drilling and milling head ER 32 AX UT
	Weight [kg]:	4.080
	Tool drive:	Flat (~DIN 1809)
	Shank size [mm]:	65.00
	Shank type:	BMT
	Tool adaption:	ER 32 A - u-tec
	Gear ratio [i]:	1:1
	Torque max [Nm]:	50
	Rotation max [1/min]:	6000
	Rotating direction:	same
Coolant:	EXT	
	8 010 66 127	Axial drilling and milling head ER 32 AX UT IC
	Weight [kg]:	4.000
	Tool drive:	Flat (~DIN 1809)
	Shank size [mm]:	65.00
	Shank type:	BMT
	Tool adaption:	ER 32 A - u-tec
	Gear ratio [i]:	1:1
	Torque max [Nm]:	50
	Rotation max [1/min]:	6000
	Rotating direction:	same
Coolant:	IC/Ext	
Pressure max [bar]:	100	
Please note:	Dryrun possible	
	8 010 67 013	Axial drilling and milling head HT 5
	Weight [kg]:	2.960
	Tool drive:	Flat (~DIN 1809)
	Shank size [mm]:	65.00
	Shank type:	BMT
	Tool adaption:	HT 5
	Gear ratio [i]:	1:1
	Torque max [Nm]:	50
	Rotation max [1/min]:	6000
	Rotating direction:	same
Coolant:	EXT	
Please note:	stronger bearing	
	8 010 67 016	Axial drilling and milling head HT 5 IC
	Weight [kg]:	2.990
	Tool drive:	Flat (~DIN 1809)
	Shank size [mm]:	65.00
	Shank type:	BMT
	Tool adaption:	HT 5
	Gear ratio [i]:	1:1
	Torque max [Nm]:	50
	Rotation max [1/min]:	6000
	Rotating direction:	same
Coolant:	IC/Ext	
Pressure max [bar]:	25	
Please note:	stronger bearing	

Part-#	Name	
8 010 67 024	Axial drilling and milling head HT 5 IC	
	Tool drive:	Flat (~DIN 1809)
	Shank size [mm]:	65.00
	Shank type:	BMT
	Tool adaption:	HT 5
	Gear ratio [i]:	1:1
	Torque max [Nm]:	50
	Rotation max [1/min]:	6000
	Rotating direction:	same
	Coolant:	IC/Ext
	Pressure max [bar]:	25
8 010 67 029	Axial drilling and milling head HT 5 IC	
	Weight [kg]:	2.960
	Tool drive:	Flat (~DIN 1809)
	Shank size [mm]:	65.00
	Shank type:	BMT
	Tool adaption:	HT 5
	Gear ratio [i]:	1:1
	Torque max [Nm]:	50
	Rotation max [1/min]:	6000
	Rotating direction:	same
	Coolant:	IC/Ext
	Pressure max [bar]:	70
	Please note:	High pressure version
8 010 67 054	Axial drilling and milling head ER 40 AX UT	
	Tool drive:	Flat (~DIN 1809)
	Shank size [mm]:	65.00
	Shank type:	BMT
	Tool adaption:	ER 40 A - u-tec
	Gear ratio [i]:	1:1
	Torque max [Nm]:	50
	Rotation max [1/min]:	5000
	Rotating direction:	same
	Coolant:	EXT
	Please note:	Combi bearing
8 010 67 062	Axial drilling and milling head Weldon 25 IC	
	Weight [kg]:	4.140
	Tool drive:	Flat (~DIN 1809)
	Shank size [mm]:	65.00
	Shank type:	BMT
	Tool adaption:	Weldon (DIN 1835 b) 25
	Gear ratio [i]:	1:1
	Torque max [Nm]:	50
	Rotation max [1/min]:	5000
	Rotating direction:	same
	Coolant:	IC/Ext
	Pressure max [bar]:	25
	Please note:	Combi bearing

Part-#	Name
8 010 67 127	Axial drilling and milling head ER 40 AX UT IC
	Weight [kg]: 4.550
	Tool drive: Flat (~DIN 1809)
	Shank size [mm]: 65.00
	Shank type: BMT
	Tool adaption: ER 40 A - u-tec
	Gear ratio [i]: 1:1
	Torque max [Nm]: 50
	Rotation max [1/min]: 5000
	Rotating direction: same
	Coolant: IC/Ext
	Pressure max [bar]: 25
	Please note: Combi bearing
8 010 67 128	Axial drilling and milling head ER 40 AX UT
	Weight [kg]: 4.620
	Tool drive: Flat (~DIN 1809)
	Shank size [mm]: 65.00
	Shank type: BMT
	Tool adaption: ER 40 A - u-tec
	Gear ratio [i]: 1:1
	Torque max [Nm]: 50
	Rotation max [1/min]: 12000
	Rotating direction: same
	Coolant: EXT
	Pressure max [bar]: 140
8 011 64 003	Axial milling head universal arbor 3/4"
	Weight [kg]: 3.800
	Tool drive: Flat (~DIN 1809)
	Shank size [mm]: 65.00
	Shank type: BMT
	Tool adaption: Universal arbor 3/4" (19,05mm)
	Gear ratio [i]: 1:1
	Torque max [Nm]: 50
	Rotation max [1/min]: 6000
	Rotating direction: same
	Coolant: EXT
	Please note: Taper roller bearings
8 011 64 004	Axial milling head universal arbor 16
	Weight [kg]: 4.110
	Tool drive: Flat (~DIN 1809)
	Shank size [mm]: 65.00
	Shank type: BMT
	Tool adaption: Universal arbor 16
	Gear ratio [i]: 1:1
	Torque max [Nm]: 50
	Rotation max [1/min]: 5000
	Rotating direction: same
	Coolant: EXT
	Please note: Combi bearing

Part-#	Name		
	8 011 64 006	Axial milling head universal arbor 3/4"	
		Weight [kg]:	4.060
		Tool drive:	Flat (~DIN 1809)
		Shank size [mm]:	65.00
		Shank type:	BMT
		Tool adaption:	Universal arbor 3/4" (19,05mm)
		Gear ratio [i]:	1:1
		Torque max [Nm]:	50
		Rotation max [1/min]:	6000
		Rotating direction:	same
		Coolant:	EXT
	Please note:	Combi bearing; without cutter retaining screw	
	8 011 65 013	Axial milling head universal arbor 22	
		Weight [kg]:	4.210
		Tool drive:	Flat (~DIN 1809)
		Shank size [mm]:	65.00
		Shank type:	BMT
		Tool adaption:	Universal arbor 22
		Gear ratio [i]:	1:1
		Torque max [Nm]:	50
		Rotation max [1/min]:	5000
		Rotating direction:	same
		Coolant:	EXT
	Please note:	Combi bearing	
	8 011 66 004	Axial milling head universal arbor 27	
		Tool drive:	Flat (~DIN 1809)
		Shank size [mm]:	65.00
		Shank type:	BMT
		Tool adaption:	Universal arbor 27
		Gear ratio [i]:	1:1
		Torque max [Nm]:	50
		Rotation max [1/min]:	6000
		Rotating direction:	same
		Coolant:	EXT
		Please note:	Taper roller bearings
	8 011 66 009	Axial milling head universal arbor 27	
		Tool drive:	Flat (~DIN 1809)
		Shank size [mm]:	65.00
		Shank type:	BMT
		Tool adaption:	Universal arbor 27
		Gear ratio [i]:	1:1
		Torque max [Nm]:	50
		Rotation max [1/min]:	5000
		Rotating direction:	same
		Coolant:	EXT
		Please note:	Combi bearing
	8 011 67 002	Axial milling head universal arbor 32	
		Tool drive:	Flat (~DIN 1809)
		Shank size [mm]:	65.00
		Shank type:	BMT
		Tool adaption:	Universal arbor 32
		Torque max [Nm]:	50

Part-#	Name	
	Rotation max [1/min]:	4000
	Rotating direction:	same
	Coolant:	EXT
	Please note:	Taper roller bearings
8 013 64 002	Axial drilling and milling head ER 16 AX UT	
	Weight [kg]:	3.500
	Tool drive:	Flat (~DIN 1809)
	Shank size [mm]:	65.00
	Shank type:	BMT
	Tool adaption:	ER 16 A - u-tec
	Gear ratio [i]:	1:4
	Torque max [Nm]:	5
	Rotation max [1/min]:	24000
	Rotating direction:	same
	Coolant:	EXT
8 013 65 002	Axial drilling and milling head ER 25 AC IC	
	Tool drive:	Flat (~DIN 1809)
	Shank size [mm]:	65.00
	Shank type:	BMT
	Tool adaption:	ER 25 A
	Gear ratio [i]:	2:1
	Torque max [Nm]:	80
	Rotation max [1/min]:	2000
	Rotating direction:	same
	Coolant:	IC/Ext
	Pressure max [bar]:	25
8 014 65 000	Axial milling head universal arbor 22	
	Weight [kg]:	7.900
	Tool drive:	Flat (~DIN 1809)
	Shank size [mm]:	65.00
	Shank type:	BMT
	Tool adaption:	Universal arbor 22
	Gear ratio [i]:	2:1
	Torque max [Nm]:	80
	Rotation max [1/min]:	2000
	Rotating direction:	same
	Coolant:	EXT
8 019 65 006	Axial drilling and milling head ER 25 AX UT	
	Weight [kg]:	6.820
	Notation:	offset; 180° reversible
	Tool drive:	Flat (~DIN 1809)
	Shank size [mm]:	65.00
	Shank type:	BMT
	Tool adaption:	ER 25 A - u-tec
	Gear ratio [i]:	1:3
	Torque max [Nm]:	12
	Rotation max [1/min]:	15000
	Rotating direction:	opposite
	Coolant:	EXT
	Please note:	stronger bearing
	Offset [mm]:	50

Part-#	Name	
	8 019 65 011	Axial drilling and milling head ER 25 AX UT IC
	Weight [kg]:	8.080
	Notation:	offset; 180° reversible
	Tool drive:	Flat (~DIN 1809)
	Shank size [mm]:	65.00
	Shank type:	BMT
	Tool adaption:	ER 25 A - u-tec
	Gear ratio [i]:	1:1
	Torque max [Nm]:	50
	Rotation max [1/min]:	12000
	Rotating direction:	opposite
	Coolant:	IC/Ext
	Pressure max [bar]:	140
	Please note:	stronger bearing
Offset [mm]:	50	
	8 030 63 000	Radial drilling and milling head Weldon 8 IC
	Notation:	180° reversible
	Tool drive:	Flat (~DIN 1809)
	Shank size [mm]:	65.00
	Shank type:	BMT
	Tool adaption:	Weldon (DIN 1835 b) 8
	Gear ratio [i]:	1:1
	Torque max [Nm]:	50
	Rotation max [1/min]:	6000
	Rotating direction:	opposite
	Coolant:	IC/Ext
	Pressure max [bar]:	25
	Center distance [mm]:	65
		8 030 64 014
Notation:		180° reversible
Tool drive:		Flat (~DIN 1809)
Shank size [mm]:		65.00
Shank type:		BMT
Tool adaption:		Weldon (DIN 1835 b) 10
Gear ratio [i]:		1:1
Torque max [Nm]:		50
Rotation max [1/min]:		6000
Rotating direction:		opposite
Coolant:		IC/Ext
Pressure max [bar]:		140
Please note:		Combi bearing
Center distance [mm]:		65
	8 030 64 022	Radial drilling and milling head Weldon 12
	Notation:	180° reversible
	Tool drive:	Flat (~DIN 1809)
	Shank size [mm]:	65.00
	Shank type:	BMT
	Tool adaption:	Weldon (DIN 1835 b) 12
	Gear ratio [i]:	1:2
	Torque max [Nm]:	16
	Rotation max [1/min]:	12000
	Rotating direction:	same
	Coolant:	EXT
	Please note:	stronger bearing
	Center distance [mm]:	80

Part-#	Name	
8 030 65 010	Radial drilling and milling head ER 25	
	Notation:	180° reversible
	Tool drive:	Flat (~DIN 1809)
	Shank size [mm]:	65.00
	Shank type:	BMT
	Tool adaption:	ER 25
	Gear ratio [i]:	1:3
	Torque max [Nm]:	12
	Rotation max [1/min]:	12000
	Rotating direction:	same
	Coolant:	EXT
	Please note:	stronger bearing
	Center distance [mm]:	75
8 030 65 014	Radial drilling and milling head ER 25	
	Weight [kg]:	8.200
	Tool drive:	Flat (~DIN 1809)
	Shank size [mm]:	65.00
	Shank type:	BMT
	Tool adaption:	ER 25
	Gear ratio [i]:	1:3
	Torque max [Nm]:	8
	Rotation max [1/min]:	15000
	Rotating direction:	opposite
	Coolant:	EXT
	Center distance [mm]:	65
8 030 65 015	Radial drilling and milling head ER 25 IC	
	Weight [kg]:	7.720
	Notation:	180° reversible
	Tool drive:	Flat (~DIN 1809)
	Shank size [mm]:	65.00
	Shank type:	BMT
	Tool adaption:	ER 25
	Gear ratio [i]:	1:3
	Torque max [Nm]:	8
	Rotation max [1/min]:	15000
	Rotating direction:	opposite
	Coolant:	IC/Ext
	Pressure max [bar]:	25
	Center distance [mm]:	65
8 030 65 018	Radial drilling and milling head ER 25 IC	
	Notation:	180° reversible
	Tool drive:	Flat (~DIN 1809)
	Shank size [mm]:	65.00
	Shank type:	BMT
	Tool adaption:	ER 25
	Gear ratio [i]:	1:1
	Torque max [Nm]:	50
	Rotation max [1/min]:	6000
	Rotating direction:	opposite
	Coolant:	IC/Ext
	Pressure max [bar]:	70
	Please note:	High pressure version
	Center distance [mm]:	65

Part-#	Name	
	8 030 65 020	Radial drilling and milling head ER 25 AX UT IC
	Weight [kg]:	7.900
	Notation:	180° reversible
	Tool drive:	Flat (~DIN 1809)
	Shank size [mm]:	65.00
	Shank type:	BMT
	Tool adaption:	ER 25 A - u-tec
	Gear ratio [i]:	1:2
	Torque max [Nm]:	16
	Rotation max [1/min]:	12000
	Rotating direction:	same
	Coolant:	IC/Ext
	Pressure max [bar]:	140
	Please note:	stronger bearing
Center distance [mm]:	80	
	8 030 65 025	Radial drilling and milling head ER 25 IC
Weight [kg]:	8.630	
Notation:	180° reversible	
Tool drive:	Flat (~DIN 1809)	
Shank size [mm]:	65.00	
Shank type:	BMT	
Tool adaption:	ER 25	
Gear ratio [i]:	1:3	
Torque max [Nm]:	12	
Rotation max [1/min]:	12000	
Rotating direction:	same	
Coolant:	IC	
Pressure max [bar]:	140	
Please note:	stronger bearing	
Center distance [mm]:	75	
	8 030 65 046	Radial drilling and milling head Weldon 16
Weight [kg]:	8.060	
Notation:	180° reversible	
Tool drive:	Flat (~DIN 1809)	
Shank size [mm]:	65.00	
Shank type:	BMT	
Tool adaption:	Weldon (DIN 1835 b) 16	
Gear ratio [i]:	1:1	
Torque max [Nm]:	50	
Rotation max [1/min]:	6000	
Rotating direction:	opposite	
Coolant:	EXT	
Please note:	Combi bearing	
Center distance [mm]:	65	
	8 030 66 001	Radial drilling and milling head Weldon 20 IC
Weight [kg]:	8.400	
Notation:	180° reversible	
Tool drive:	Flat (~DIN 1809)	
Shank size [mm]:	65.00	
Shank type:	BMT	
Tool adaption:	Weldon (DIN 1835 b) 20	
Gear ratio [i]:	1:1	
Torque max [Nm]:	50	
Rotation max [1/min]:	6000	
Rotating direction:	opposite	

Part-#	Name
--------	------

Coolant: IC/Ext
 Pressure max [bar]: 25
 Please note: stronger bearing
 Center distance [mm]: 65

8 030 66 004 Radial drilling and milling head Weldon 20 IC

Notation: 180° reversible
 Tool drive: Flat (~DIN 1809)
 Shank size [mm]: 65.00
 Shank type: BMT
 Tool adaption: Weldon (DIN 1835 b) 20
 Gear ratio [i]: 1,625:1
 Torque max [Nm]: 63
 Rotation max [1/min]: 6000
 Rotating direction: opposite
 Coolant: IC/Ext
 Pressure max [bar]: 25
 Please note: stronger bearing
 Center distance [mm]: 65

8 030 66 078 Angle-mill- and drill holder ER 32 AX UT

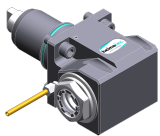

Weight [kg]: 8.340
 Notation: 180° reversible
 Tool drive: Flat (~DIN 1809)
 Shank size [mm]: 65.00
 Shank type: BMT
 Tool adaption: ER 32 A - u-tec
 Gear ratio [i]: 1:1
 Torque max [Nm]: 50
 Rotation max [1/min]: 6000
 Rotating direction: opposite
 Coolant: EXT
 Please note: Combi bearing
 Center distance [mm]: 65

8 030 66 090 Angle-mill- and drill holder ER 32 AX UT IC



Weight [kg]: 8.240
 Notation: 180° reversible
 Tool drive: Flat (~DIN 1809)
 Shank size [mm]: 65.00
 Shank type: BMT
 Tool adaption: ER 32 A - u-tec
 Gear ratio [i]: 1:1
 Torque max [Nm]: 50
 Rotation max [1/min]: 6000
 Rotating direction: opposite
 Coolant: IC/Ext
 Pressure max [bar]: 140
 Please note: Combi bearing
 Center distance [mm]: 65

Part-#	Name
--------	------

8 030 66 103

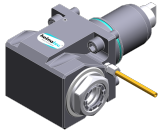

Radial drilling and milling head ER 32 AX UT

Notation: 180° reversible
 Tool drive: Flat (~DIN 1809)
 Shank size [mm]: 65.00
 Shank type: BMT
 Tool adaption: ER 32 A - u-tec
 Gear ratio [i]: 2:1
 Torque max [Nm]: 63
 Rotation max [1/min]: 3000
 Rotating direction: opposite
 Coolant: EXT
 Please note: Combi bearing
 Center distance [mm]: 65

8 030 66 127



Radial drilling and milling head ER 32 AX UT IC

Notation: 180° reversible
 Tool drive: Flat (~DIN 1809)
 Shank size [mm]: 65.00
 Shank type: BMT
 Tool adaption: ER 32 A - u-tec
 Gear ratio [i]: 2:1
 Torque max [Nm]: 63
 Rotation max [1/min]: 3000
 Rotating direction: opposite
 Coolant: IC/Ext
 Pressure max [bar]: 140
 Please note: Combi bearing
 Center distance [mm]: 65

8 030 66 257



Radial drilling and milling head ER 32 AX UT IC

Weight [kg]: 7.800
 Notation: 180° reversible
 Tool drive: Flat (~DIN 1809)
 Shank size [mm]: 65.00
 Shank type: BMT
 Tool adaption: ER 32 A - u-tec
 Gear ratio [i]: 1:1
 Torque max [Nm]: 50
 Rotation max [1/min]: 12000
 Rotating direction: opposite
 Coolant: IC/Ext
 Pressure max [bar]: 140
 Center distance [mm]: 65

8 030 66 259



Radial drilling and milling head ER 32 AX UT IC

Weight [kg]: 11.100
 Notation: 180° reversible
 Tool drive: Flat (~DIN 1809)
 Shank size [mm]: 65.00
 Shank type: BMT
 Tool adaption: ER 32 A - u-tec
 Gear ratio [i]: 1:1
 Torque max [Nm]: 50
 Rotation max [1/min]: 6000
 Rotating direction: opposite
 Coolant: IC/Ext

Part-#	Name
--------	------

Pressure max [bar]: 140
Please note: Combi bearing
Center distance [mm]: 100

8 030 66 263 Radial drilling and milling head ER 32 AX UT

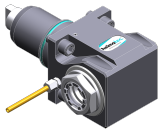

Weight [kg]: 7.600
Notation: 180° reversible
Tool drive: Flat (~DIN 1809)
Shank size [mm]: 65.00
Shank type: BMT
Tool adaption: ER 32 A - u-tec
Gear ratio [i]: 1:1
Torque max [Nm]: 50
Rotation max [1/min]: 12000
Rotating direction: opposite
Coolant: EXT
Center distance [mm]: 65

8 030 67 003 Radial drilling and milling head Weldon 25 IC

Weight [kg]: 8.720
Notation: 180° reversible
Version: Special
Tool drive: Flat (~DIN 1809)
Shank size [mm]: 65.00
Shank type: BMT
Tool adaption: Weldon (DIN 1835 b) 25 special
Gear ratio [i]: 1:1
Torque max [Nm]: 50
Rotation max [1/min]: 6000
Rotating direction: opposite
Coolant: IC/Ext
Pressure max [bar]: 25
Please note: stronger bearing
Center distance [mm]: 65

8 030 67 007 Radial drilling and milling head ER 40

Weight [kg]: 7.300
Notation: 180° reversible
Tool drive: Flat (~DIN 1809)
Shank size [mm]: 65.00
Shank type: BMT
Tool adaption: ER 40
Gear ratio [i]: 1,625:1
Torque max [Nm]: 63
Rotation max [1/min]: 4000
Rotating direction: opposite
Coolant: EXT
Center distance [mm]: 65

8 030 67 008 Radial drilling and milling head ER 40

Weight [kg]: 7.260
Notation: 180° reversible
Tool drive: Flat (~DIN 1809)
Shank size [mm]: 65.00
Shank type: BMT
Tool adaption: ER 40
Gear ratio [i]: 1:1

Part-#	Name	
	Torque max [Nm]:	50
	Rotation max [1/min]:	6000
	Rotating direction:	opposite
	Coolant:	EXT
	Center distance [mm]:	65
8 030 67 027	Radial drilling and milling head Weldon 25 IC	
	Notation:	180° reversible
	Tool drive:	Flat (~DIN 1809)
	Shank size [mm]:	65.00
	Shank type:	BMT
	Tool adaption:	Weldon (DIN 1835 b) 25
	Gear ratio [i]:	1:1
	Torque max [Nm]:	50
	Rotation max [1/min]:	6000
	Rotating direction:	opposite
	Coolant:	IC/Ext
	Pressure max [bar]:	140
	Please note:	stronger bearing
	Center distance [mm]:	65
8 030 67 028	Radial drilling and milling head HT 5 IC	
	Weight [kg]:	9.200
	Notation:	180° reversible
	Version:	Special
	Tool drive:	Flat (~DIN 1809)
	Shank size [mm]:	65.00
	Shank type:	BMT
	Tool adaption:	HT 5
	Gear ratio [i]:	1:1
	Torque max [Nm]:	50
	Rotation max [1/min]:	6000
	Rotating direction:	opposite
	Coolant:	IC/Ext
	Pressure max [bar]:	25
	Center distance [mm]:	91
8 030 67 037	Radial drilling and milling head Weldon 25 IC	
	Notation:	180° reversible
	Tool drive:	Flat (~DIN 1809)
	Shank size [mm]:	65.00
	Shank type:	BMT
	Tool adaption:	Weldon (DIN 1835 b) 25
	Gear ratio [i]:	2:1
	Torque max [Nm]:	63
	Rotation max [1/min]:	3000
	Rotating direction:	opposite
	Coolant:	IC/Ext
	Pressure max [bar]:	25
	Please note:	stronger bearing
	Center distance [mm]:	65

Part-#	Name
--------	------

8 030 67 088

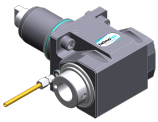

Radial drilling and milling head HT 5 IC

Weight [kg]:	8.420
Notation:	180° reversible
Tool drive:	Flat (~DIN 1809)
Shank size [mm]:	65.00
Shank type:	BMT
Tool adaption:	HT 5
Gear ratio [i]:	1:1
Torque max [Nm]:	50
Rotation max [1/min]:	6000
Rotating direction:	opposite
Coolant:	IC/Ext
Pressure max [bar]:	140
Please note:	Combi bearing
Center distance [mm]:	65

8 030 67 120

Radial drilling and milling head Weldon 25

Notation:	180° reversible
Tool drive:	Flat (~DIN 1809)
Shank size [mm]:	65.00
Shank type:	BMT
Tool adaption:	Weldon (DIN 1835 b) 25
Gear ratio [i]:	2:1
Torque max [Nm]:	63
Rotation max [1/min]:	3000
Rotating direction:	opposite
Coolant:	EXT
Please note:	Combi bearing
Center distance [mm]:	65

8 030 67 140



Radial drilling and milling head ER 40 AX UT

Notation:	180° reversible
Tool drive:	Flat (~DIN 1809)
Shank size [mm]:	65.00
Shank type:	BMT
Tool adaption:	ER 40 A - u-tec
Gear ratio [i]:	1:1
Torque max [Nm]:	50
Rotation max [1/min]:	12000
Rotating direction:	opposite
Coolant:	EXT
Pressure max [bar]:	140
Please note:	stronger bearing
Center distance [mm]:	65

8 030 67 156



Radial drilling and milling head ER 40 AX UT IC

Notation:	180° reversible
Tool drive:	Flat (~DIN 1809)
Shank size [mm]:	65.00
Shank type:	BMT
Tool adaption:	ER 40 A - u-tec
Gear ratio [i]:	1:1
Torque max [Nm]:	50
Rotation max [1/min]:	6000
Rotating direction:	opposite
Coolant:	IC/Ext
Pressure max [bar]:	140

Part-#	Name	
	Please note:	stronger bearing
	Center distance [mm]:	65
8 037 64 004	Radial disk mill head arbor 16	
	Weight [kg]:	12.840
	Notation:	180° reversible
	Version:	± 10° turnable
	Tool drive:	Flat (~DIN 1809)
	Shank size [mm]:	65.00
	Shank type:	BMT
	Tool adaption:	Arbor 16
	Gear ratio [i]:	2:1
	Torque max [Nm]:	63
	Rotation max [1/min]:	3000
	Rotating direction:	same
	Coolant:	no
	Please note:	strong version; stronger bearing
	Center distance [mm]:	87,5
8 037 65 000	Woodruff keycutter ER 25 AS	
	Weight [kg]:	7.800
	Tool drive:	Flat (~DIN 1809)
	Shank size [mm]:	65.00
	Shank type:	BMT
	Tool adaption:	ER 25 A
	Gear ratio [i]:	1,333:1
	Torque max [Nm]:	32
	Rotation max [1/min]:	2250
	Rotating direction:	opposite
	Coolant:	EXT
8 037 65 002	Radial disk mill head arbor 22	
	Weight [kg]:	13.420
	Notation:	180° reversible
	Version:	± 10° turnable
	Tool drive:	Flat (~DIN 1809)
	Shank size [mm]:	65.00
	Shank type:	BMT
	Tool adaption:	Arbor 22
	Gear ratio [i]:	2:1
	Torque max [Nm]:	63
	Rotation max [1/min]:	3000
	Rotating direction:	same
	Coolant:	no
	Please note:	strong version with stronger bearing
	Center distance [mm]:	87,5
8 037 66 000	Radial disk mill head arbor 27	
	Weight [kg]:	13.260
	Tool drive:	Flat (~DIN 1809)
	Shank size [mm]:	65.00
	Shank type:	BMT
	Tool adaption:	Arbor 27
	Gear ratio [i]:	2:1
	Torque max [Nm]:	63
	Rotation max [1/min]:	3000
	Rotating direction:	same
	Coolant:	no

Part-#	Name
--------	------

Please note: strong version; stronger bearing
Center distance [mm]: 87,5

8 039 64 001 Radial drilling and milling head ER 16

Weight [kg]: 7.800
Notation: 60° angle
Tool drive: Flat (~DIN 1809)
Shank size [mm]: 65.00
Shank type: BMT
Tool adaption: ER 16
Gear ratio [i]: 1:1
Torque max [Nm]: 16
Rotation max [1/min]: 6000
Rotating direction: opposite
Coolant: EXT

8 039 64 002 Radial drilling and milling head ER 16

Weight [kg]: 7.620
Notation: 30° angle
Tool drive: Flat (~DIN 1809)
Shank size [mm]: 65.00
Shank type: BMT
Tool adaption: ER 16
Gear ratio [i]: 1:1
Torque max [Nm]: 16
Rotation max [1/min]: 6000
Rotating direction: opposite
Coolant: EXT

8 039 64 003 Radial drilling and milling head ER 16

Weight [kg]: 7.520
Notation: 45° angle
Tool drive: Flat (~DIN 1809)
Shank size [mm]: 65.00
Shank type: BMT
Tool adaption: ER 16
Gear ratio [i]: 1:1
Torque max [Nm]: 16
Rotation max [1/min]: 6000
Rotating direction: opposite
Coolant: EXT

8 039 65 014 Radial drilling and milling head ER 25 AX UT

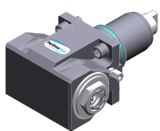

Weight [kg]: 8.760
Notation: 180° reversible
Employment for: Main- and sub spindle
Version: double spindle
Tool drive: Flat (~DIN 1809)
Shank size [mm]: 65.00
Shank type: BMT
Tool adaption: ER 25 A - u-tec
Gear ratio [i]: 1:1
Torque max [Nm]: 50
Rotation max [1/min]: 12000
Rotating direction: same/opposite
Coolant: EXT
Please note: stronger bearing

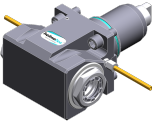
Part-#	Name	
	Center distance [mm]:	65
8 039 66 004	Radial milling head universal arbor 27	
	Weight [kg]:	9.480
	Notation:	100° angle
	Tool drive:	Flat (~DIN 1809)
	Shank size [mm]:	65.00
	Shank type:	BMT
	Tool adaption:	Universal arbor 27
	Gear ratio [i]:	1,438:1
	Torque max [Nm]:	40
	Rotation max [1/min]:	4000
	Rotating direction:	opposite
	Coolant:	EXT
	Please note:	stronger bearing
8 039 66 028	Radial drilling and milling head ER 32 AX UT	
	Weight [kg]:	8.600
	Notation:	180° reversible
	Employment for:	Main- and sub spindle
	Version:	double spindle
	Tool drive:	Flat (~DIN 1809)
	Shank size [mm]:	65.00
	Shank type:	BMT
	Tool adaption:	ER 32 A - u-tec
	Gear ratio [i]:	1:1
	Torque max [Nm]:	50
	Rotation max [1/min]:	12000
	Rotating direction:	same/opposite
	Coolant:	EXT
	Please note:	stronger bearing
	Center distance [mm]:	65
8 040 64 000	Universal head ± 90° adjustable ER 16	
	Weight [kg]:	4.800
	Tool drive:	Flat (~DIN 1809)
	Shank size [mm]:	65.00
	Shank type:	BMT
	Tool adaption:	ER 16
	Gear ratio [i]:	1:1
	Torque max [Nm]:	10
	Rotation max [1/min]:	5000
	Rotating direction:	same
	Coolant:	EXT
	Center distance [mm]:	64
8 043 64 003	Universal head +100°/-20° adj. ER16 AX UT	
	Weight [kg]:	8.910
	Notation:	offset; 180° reversible
	Tool drive:	Flat (~DIN 1809)
	Shank size [mm]:	65.00
	Shank type:	BMT
	Tool adaption:	ER 16 A - u-tec
	Gear ratio [i]:	1:1
	Torque max [Nm]:	25
	Rotation max [1/min]:	6000
	Rotating direction:	opposite

Part-#	Name
--------	------

Coolant: EXT
Center distance [mm]: 60
Offset [mm]: 35

8 043 64 007 Universal head +145°/-25° adj. ER16AX UTIK





Weight [kg]: 8.680
Notation: offset; 180° reversible
Tool drive: Flat (~DIN 1809)
Shank size [mm]: 65.00
Shank type: BMT
Tool adaption: ER 16 A - u-tec
Gear ratio [i]: 1:1
Torque max [Nm]: 25
Rotation max [1/min]: 6000
Rotating direction: same
Coolant: IC/Ext
Pressure max [bar]: 140
Center distance [mm]: 60
Offset [mm]: 60

8 043 64 012 Universal head +100°/-20° adj. ER16AX UTIK

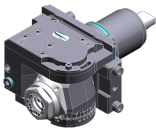

Weight [kg]: 8.960
Notation: offset; 180° reversible
Tool drive: Flat (~DIN 1809)
Shank size [mm]: 65.00
Shank type: BMT
Tool adaption: ER 16 A - u-tec
Gear ratio [i]: 1:2
Torque max [Nm]: 12
Rotation max [1/min]: 12000
Rotating direction: opposite
Coolant: IC/Ext
Pressure max [bar]: 25
Center distance [mm]: 60
Offset [mm]: 35

8 043 64 026 Universal head +100°/-20° adj. ER16AX UTIK

Weight [kg]: 8.920
Notation: offset; 180° reversible
Tool drive: Flat (~DIN 1809)
Shank size [mm]: 65.00
Shank type: BMT
Tool adaption: ER 16 A - u-tec
Gear ratio [i]: 1:1
Torque max [Nm]: 25
Rotation max [1/min]: 6000
Rotating direction: opposite
Coolant: IC/Ext
Pressure max [bar]: 25
Center distance [mm]: 60
Offset [mm]: 35

Part-#	Name	
	8 043 65 002	Universal head +100°/-20° adj. ER25 AX UT
	Weight [kg]:	8.870
	Notation:	offset; 180° reversible
	Tool drive:	Flat (~DIN 1809)
	Shank size [mm]:	65.00
	Shank type:	BMT
	Tool adaption:	ER 25 A - u-tec
	Gear ratio [i]:	1:1
	Torque max [Nm]:	25
	Rotation max [1/min]:	6000
	Rotating direction:	opposite
	Coolant:	EXT
	Please note:	stronger bearing
	Center distance [mm]:	60
Offset [mm]:	35	
	8 043 65 011	Universal head +100°/-20° adj. ER25AX UTIK
	Weight [kg]:	9.170
	Notation:	offset; 180° reversible
	Tool drive:	Flat (~DIN 1809)
	Shank size [mm]:	65.00
	Shank type:	BMT
	Tool adaption:	ER 25 A - u-tec
	Gear ratio [i]:	1:1
	Torque max [Nm]:	25
	Rotation max [1/min]:	6000
	Rotating direction:	opposite
	Coolant:	IC/Ext
	Pressure max [bar]:	25
	Please note:	stronger bearing
Center distance [mm]:	60	
Offset [mm]:	35	
	8 068 64 000	Radial whirling unit HW 46
	Notation:	180° reversible
	Tool drive:	Flat (~DIN 1809)
	Shank size [mm]:	65.00
	Shank type:	BMT
	Tool adaption:	HW 46
	Gear ratio [i]:	1:1
	Torque max [Nm]:	16
	Rotation max [1/min]:	8000
	Rotating direction:	same
	Coolant:	EXT
	Please note:	without cutting inserts carrier; check applicability;
	Center distance [mm]:	80
		8 200 03 001
Weight [kg]:		0.438
Shank type:		BMT
	8 202 10 002	Basic holder for height adjustable adapter
	Shank type: Machine adaption:	BMT Centering key b 20

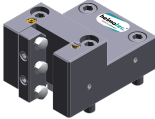
Part-#	Name	
8 202 10 003	Basic holder for height adjustable adapter	
	Weight [kg]:	2.840
	Shank type:	BMT
	Machine adaption:	Centering key b 20
	Coolant:	EXT
8 202 10 008	Basic holder longitudinal seat FN 12	
	Weight [kg]:	1.200
	Notation:	180° reversible
	Shank type:	BMT
	Machine adaption:	Centering key b 20
	Tool adaption:	Interface FN 12
	Coolant:	EXT
8 208 69 003	Test mandrel BMT 65	
	Weight [kg]:	3.280
	Shank size [mm]:	65.00
	Shank type:	BMT
8 209 14 000	Adapter for VDI 40	
	Weight [kg]:	4.560
	Shank type:	BMT
	Machine adaption:	Centering key b 20
	Tool adaption:	DIN 69880 - 40
	Coolant:	EXT
	Center distance [mm]:	35
8 209 14 001	Adapter for VDI 40	
	Weight [kg]:	5.310
	Notation:	180° reversible; offset
	Shank type:	BMT
	Machine adaption:	Centering key b 20
	Tool adaption:	DIN 69880 - 40
	Coolant:	EXT
	Center distance [mm]:	80
8 224 12 010	Cut-off holder sq. 25	
	Weight [kg]:	2.040
	Employment for:	right cutting tools
	Version:	Edge on side of turret
	Shank type:	BMT
	Machine adaption:	Centering key slot b 20
	Tool adaption:	Sq. 25
	Coolant:	EXT
8 224 12 011	Cut-off holder sq. 25	
	Weight [kg]:	2.040
	Employment for:	left cutting tools
	Version:	Edge on center of turret
	Shank type:	BMT
	Machine adaption:	Centering key b 20
	Tool adaption:	Sq. 25
	Coolant:	EXT

Part-#	Name	
8 224 13 008	Cut-off holder SH 32	
	Weight [kg]:	1.840
	Employment for:	Cut-off tool 32
	Version:	Clampshaft on turret side
	Shank type:	BMT
	Machine adaption:	Centering key b 20
	Tool adaption:	Clampshaft SH 32
	Coolant:	EXT
8 224 13 009	Cut-off holder SH 32	
	Weight [kg]:	1.170
	Employment for:	Cut-off tool 32
	Version:	Clampshaft on turret center
	Shank type:	BMT
	Machine adaption:	Centering key b 20
	Tool adaption:	Clampshaft SH 32
	Coolant:	EXT
8 224 15 000	Universal turning holder sq. 25	
	Weight [kg]:	4.380
	Notation:	180° reversible
	Shank type:	BMT
	Machine adaption:	Centering key b 20
	Tool adaption:	Sq. 25
		Sq. 25
	Coolant:	EXT
8 224 15 008	Universal turning holder sq. 1"	
	Weight [kg]:	4.370
	Notation:	180° reversible
	Shank type:	BMT
	Machine adaption:	Centering key b 20
	Tool adaption:	Sq. 1" (25,4mm)
		Sq. 1" (25,4mm)
	Coolant:	EXT
8 224 15 038	Universal turning holder sq. 25 IC	
	Weight [kg]:	4.380
	Shank type:	BMT
	Machine adaption:	Centering key b 20
	Tool adaption:	Sq. 25
		Sq. 25
	Coolant:	IC/Ext
8 224 15 051	Universal turning holder sq. 25 IC	
	Weight [kg]:	4.380
	Notation:	180° reversible
	Shank type:	BMT
	Machine adaption:	Centering key b 20
	Tool adaption:	Sq. 25
		Sq. 25
	Coolant:	IC/Ext
	Pressure max [bar]:	100
	Please note:	Key rail

Part-#	Name	
8 225 12 002	Cut-off holder sq. 25	
	Weight [kg]:	1.640
	Employment for:	left cutting tools
	Version:	Edge on side of turret
	Shank type:	BMT
	Machine adaption:	Centering key b 20
	Tool adaption:	Sq. 25
	Coolant:	EXT
8 225 12 003	Cut-off holder sq. 25	
	Employment for:	right cutting tools
	Version:	Edge on center of turret
	Shank type:	BMT
	Machine adaption:	Centering key b 20
	Tool adaption:	Sq. 25
	Coolant:	EXT
8 229 16 007	Tool holder C 4 IC	
	Notation:	180° reversible
	Version:	right
	Shank type:	BMT
	Machine adaption:	Centering key b 20
	Tool adaption:	heimatec Capto(TM) C 4
	Coolant:	IC
	Please note:	Check applicability; note tool length!
	Offset [mm]:	75
8 229 17 000	Tool holder C 5 IC	
	Weight [kg]:	5.900
	Notation:	180° reversible
	Version:	right
	Shank type:	BMT
	Machine adaption:	Centering key b 20
	Tool adaption:	heimatec Capto(TM) C 5
	Coolant:	IC/Ext
	Please note:	Check applicability; note tool length!
	Offset [mm]:	85
8 240 15 009	Insert drill holder 16 IC	
	Notation:	180° reversible
	Shank type:	BMT
	Tool adaption:	Whistle-Notch (DIN 1835 E) 16
	Coolant:	IC
	Center distance [mm]:	85
8 240 16 003	Boring bar holder Ø 20	
	Weight [kg]:	5.700
	Notation:	180° reversible
	Shank type:	BMT
	Machine adaption:	Centering key b 20
	Tool adaption:	Ø 20
	Coolant:	IC/Ext
	Center distance [mm]:	90

Part-#	Name	
8 240 16 011	Insert drill holder 20 IC	
	Weight [kg]:	7.660
	Notation:	180° reversible
	Shank type:	BMT
	Tool adaption:	Ø 20
	Coolant:	IC
	Center distance [mm]:	85
8 240 16 015	Tool holder hydro 20 - blank	
	Weight [kg]:	4.280
	Notation:	180° reversible
	Version:	Special
	Shank type:	BMT
	Machine adaption:	Centering key b 20
	Tool adaption:	Blank for hydro clamp
	Coolant:	IC/Ext
	Center distance [mm]:	90
8 240 16 031	Collet chuck holder ER 32	
	Notation:	180° reversible
	Shank type:	BMT
	Machine adaption:	Centering key b 20
	Tool adaption:	ER 32
	Coolant:	IC/Ext
	Center distance [mm]:	90
8 240 17 000	Boring bar holder Ø 25	
	Weight [kg]:	5.440
	Shank type:	BMT
	Machine adaption:	Centering key b 20
	Tool adaption:	Ø 25
	Coolant:	IC/Ext
	Center distance [mm]:	90
8 240 17 010	Boring bar holder Ø 30	
	Weight [kg]:	5.960
	Shank type:	BMT
	Machine adaption:	Centering key b 20
	Tool adaption:	Ø 30
	Coolant:	EXT
	Center distance [mm]:	57,5
8 240 17 018	Tool holder HT 5	
	Weight [kg]:	6.480
	Shank type:	BMT
	Machine adaption:	Centering key b 20
	Tool adaption:	HT 5
	Coolant:	IC/Ext
	Center distance [mm]:	90
8 240 17 019	Tool holder HT 5	
	Weight [kg]:	6.080
	Notation:	offset
	Shank type:	BMT
	Machine adaption:	Centering key b 20
	Tool adaption:	HT 5
	Coolant:	IC/Ext

Part-#	Name	
	Center distance [mm]:	90
8 240 17 025	Insert drill holder 25 IC	
	Weight [kg]:	7.630
	Notation:	180° reversible
	Shank type:	BMT
	Tool adaption:	Whistle-Notch (DIN 1835 E) 25
	Coolant:	IC
	Center distance [mm]:	85
8 240 17 060	Collet chuck holder ER 40	
	Notation:	180° reversible
	Shank type:	BMT
	Machine adaption:	Centering key b 20
	Tool adaption:	ER 40
	Coolant:	IC/Ext
	Center distance [mm]:	90
8 240 17 082	Tool holder C 5 IC	
	Weight [kg]:	6.020
	Notation:	180° reversible
	Version:	offset; right
	Shank type:	BMT
	Machine adaption:	Centering key b 20
	Tool adaption:	heimatec Capto(TM) C 5
	Coolant:	IC
	Center distance [mm]:	80
8 240 17 113	Tool holder C 5 IC	
	Weight [kg]:	7.200
	Notation:	180° reversible
	Version:	right
	Shank type:	BMT
	Machine adaption:	Centering key b 20
	Tool adaption:	heimatec Capto(TM) C 5
	Coolant:	IC
	Center distance [mm]:	80
8 240 18 000	Boring bar holder Ø 32	
	Weight [kg]:	5.220
	Notation:	180° reversible
	Shank type:	BMT
	Machine adaption:	Centering key b 20
	Tool adaption:	Ø 32
	Coolant:	IC/Ext
	Center distance [mm]:	90
8 240 18 002	Boring bar holder Ø 32	
	Weight [kg]:	5.760
	Notation:	offset
	Shank type:	BMT
	Machine adaption:	Centering key b 20
	Tool adaption:	Ø 32
	Coolant:	IC/Ext
	Center distance [mm]:	90

Part-#	Name	
8 240 18 003	Boring bar holder Ø 32	
	Weight [kg]:	5.780
	Shank type:	BMT
	Machine adaption:	Centering key b 20
	Tool adaption:	Ø 32
	Coolant:	IC/Ext
	Center distance [mm]:	107,5
8 240 18 020	Boring bar holder Ø 32	
	Weight [kg]:	3.800
	Version:	Special
	Shank type:	BMT
	Machine adaption:	Centering key b 20
	Tool adaption:	Ø 32
	Coolant:	IC/Ext
	Center distance [mm]:	60
8 240 18 022	Insert drill holder 32 IC	
	Weight [kg]:	7.400
	Notation:	180° reversible
	Shank type:	BMT
	Tool adaption:	Ø 32
	Coolant:	IC
	Center distance [mm]:	85
8 240 18 035	Boring bar holder Ø 1 1/2"	
	Weight [kg]:	4.910
	Notation:	180° reversible
	Shank type:	BMT
	Machine adaption:	Centering key b 20
	Tool adaption:	Ø 1 1/2" (38,1mm)
	Coolant:	IC/Ext
	Center distance [mm]:	90
8 240 18 041	Boring bar holder Ø 1 1/4"	
	Weight [kg]:	5.160
	Notation:	180° reversible
	Shank type:	BMT
	Machine adaption:	Centering key b 20
	Tool adaption:	Ø 1 1/4" (31,75mm)
	Coolant:	IC/Ext
	Center distance [mm]:	90
8 240 19 000	Boring bar holder Ø 40	
	Weight [kg]:	4.830
	Notation:	180° reversible
	Shank type:	BMT
	Machine adaption:	Centering key b 20
	Tool adaption:	Ø 40
	Coolant:	IC/Ext
	Center distance [mm]:	90





Part-#	Name	
8 240 19 003	Boring bar holder Ø 40	
	Weight [kg]:	5.640
	Notation:	180° reversible
	Shank type:	BMT
	Machine adaption:	Centering key b 20
	Tool adaption:	Ø 40
	Coolant:	IC/Ext
	Center distance [mm]:	107,5
8 240 19 004	Boring bar holder Ø 50	
	Weight [kg]:	7.600
	Notation:	offset
	Shank type:	BMT
	Machine adaption:	Centering key b 20
	Tool adaption:	Ø 50
	Coolant:	IC/Ext
	Center distance [mm]:	85
8 240 19 005	Boring bar holder Ø 40 offset	
	Weight [kg]:	7.920
	Notation:	180° reversible
	Version:	offset
	Shank type:	BMT
	Machine adaption:	Centering key b 20
	Tool adaption:	Ø 40
	Coolant:	IC/Ext
	Center distance [mm]:	90
	Offset [mm]:	60
8 240 19 006	Boring bar holder Ø 42	
	Notation:	180° reversible
	Version:	Special
	Shank type:	BMT
	Machine adaption:	Centering key b 20
	Tool adaption:	Ø 42
	Coolant:	IC/Ext
	Center distance [mm]:	90
8 240 19 017	Boring bar holder Ø 40	
	Weight [kg]:	3.540
	Version:	Special
	Shank type:	BMT
	Machine adaption:	Centering key b 20
	Tool adaption:	Ø 40
	Coolant:	IC/Ext
	Center distance [mm]:	60
8 240 19 019	Insert drill holder 40 IC	
	Weight [kg]:	7.100
	Notation:	180° reversible
	Shank type:	BMT
	Tool adaption:	Ø 40
	Coolant:	IC
	Center distance [mm]:	85

Part-#	Name	
8 244 12 000	Facing holder sq. 25	
	Weight [kg]:	5.460
	Notation:	180° reversible
	Shank type:	BMT
	Machine adaption:	Centering key b 20
	Tool adaption:	Sq. 25
	Coolant:	EXT
8 249 16 011	Double collet chuck holder ER 32	
	Weight [kg]:	5.940
	Notation:	180° reversible
	Employment for:	Main- and sub spindle
	Shank type:	BMT
	Machine adaption:	Centering key b 20
	Tool adaption:	ER 32
		ER 32
	Coolant:	IC/Ext
	Center distance [mm]:	90
8 249 17 006	Double collet chuck holder ER 40	
	Notation:	180° reversible
	Employment for:	Main- and sub spindle
	Shank type:	BMT
	Machine adaption:	Centering key b 20
	Tool adaption:	ER 40
		ER 40
	Coolant:	IC/Ext
	Center distance [mm]:	90
8 250 16 006	Double tool holder C 4 IC	
	Weight [kg]:	5.500
	Employment for:	Main- and sub spindle
	Version:	right
	Shank type:	BMT
	Machine adaption:	Centering key b 20
	Tool adaption:	heimatec Capto(TM) C 4
		heimatec Capto(TM) C 4
	Coolant:	IC
	Please note:	Check applicability; note tool length!
	Offset [mm]:	±75
8 250 16 010	Double tool holder C 4 IC	
	Weight [kg]:	2.940
	Employment for:	Main- and sub spindle
	Version:	right
	Shank type:	BMT
	Machine adaption:	Centering key b 20
	Tool adaption:	heimatec Capto(TM) C 4
		heimatec Capto(TM) C 4
	Coolant:	IC
	Pressure max [bar]:	80
	Please note:	Check applicability; note tool length!
	Offset [mm]:	±24

Part-#	Name	
8 251 12 000	Double turning holder sq. 25	
	Weight [kg]:	6.920
	Employment for:	right cutting tools
	Shank type:	BMT
	Machine adaption:	Centering key b 20
	Tool adaption:	Sq. 25
	Coolant:	EXT
8 251 15 000	Combi double turning holder sq. 25	
	Weight [kg]:	6.800
	Shank type:	BMT
	Machine adaption:	Centering key b 20
	Tool adaption:	Sq. 25
		Sq. 25
		Sq. 25
		Sq. 25
	Coolant:	EXT
8 251 15 007	Combi double turning holder sq. 1"	
	Weight [kg]:	6.780
	Shank type:	BMT
	Machine adaption:	Centering key b 20
	Tool adaption:	Sq. 1" (25,4mm)
		Sq. 1" (25,4mm)
		Sq. 1" (25,4mm)
		Sq. 1" (25,4mm)
	Coolant:	EXT
8 253 15 016	Double boring bar holder Ø 16	
	Weight [kg]:	5.440
	Notation:	180° reversible
	Shank type:	BMT
	Machine adaption:	Centering key b 20
	Tool adaption:	Ø 16
		Ø 16
	Coolant:	IC/Ext
	Please note:	untere boring bar zur main spindle obere boring bar zur
	Center distance [mm]:	57,5/100
8 253 16 000	Double tool holder HT 4	
	Weight [kg]:	6.620
	Shank type:	BMT
	Machine adaption:	Centering key b 20
	Tool adaption:	HT 4
	Coolant:	IC/Ext
	Please note:	Holder 180° reversible
	Center distance [mm]:	57,5/100
8 253 16 035	Double boring bar holder Ø 20	
	Weight [kg]:	5.280
	Notation:	180° reversible
	Shank type:	BMT
	Machine adaption:	Centering key b 20
	Tool adaption:	Ø 20
		Ø 20
	Coolant:	IC/Ext
	Please note:	untere boring bar zur main spindle obere boring bar zur

Part-#	Name	
	Center distance [mm]:	57,5/100
8 253 17 003	Double boring bar holder Ø 25	
	Weight [kg]:	5.680
	Shank type:	BMT
	Machine adaption:	Centering key b 20
	Tool adaption:	Ø 25
	Coolant:	IC/Ext
	Center distance [mm]:	57,5/107,5
8 253 17 007	Double boring bar holder Ø 25	
	Weight [kg]:	4.980
	Notation:	180° reversible
	Shank type:	BMT
	Machine adaption:	Centering key b 20
	Tool adaption:	Ø 25
	Coolant:	IC/Ext
	Center distance [mm]:	57,5/100
8 253 17 041	Double boring bar holder Ø 25	
	Weight [kg]:	5.560
	Notation:	180° reversible
	Version:	Special
	Shank type:	BMT
	Machine adaption:	Centering key b 20
	Tool adaption:	Ø 25
	Coolant:	IC/Ext
	Center distance [mm]:	65/110
8 253 17 050	Double boring bar holder Ø 1"	
	Weight [kg]:	4.940
	Notation:	180° reversible
	Shank type:	BMT
	Machine adaption:	Centering key b 20
	Tool adaption:	Ø 1" (25,4mm)
	Coolant:	IC/Ext
	Center distance [mm]:	57,5/100
8 253 17 089	Double boring bar holder Ø 25	
	Weight [kg]:	4.980
	Notation:	180° reversible
	Shank type:	BMT
	Machine adaption:	Centering key b 20
	Tool adaption:	Ø 25
	Coolant:	IC/Ext
	Please note:	untere boring bar zur main spindle obere boring bar zur
	Center distance [mm]:	57,5/100

Part-#	Name	
8 253 18 018	Double boring bar holder Ø 32	
	Weight [kg]:	8.420
	Notation:	180° reversible
	Shank type:	BMT
	Machine adaption:	Centering key b 20
	Tool adaption:	Ø 32
		Ø 32
	Coolant:	IC/Ext
	Please note:	untere boring bar zur main spindle obere boring bar zur
	Center distance [mm]:	57,5/100
8 261 18 002	Tool holder for centering insert	
	Weight [kg]:	6.110
	Notation:	180° reversible
	Shank type:	BMT
	Machine adaption:	Centering key b 20
	Tool adaption:	Ø 32
	Coolant:	EXT
	Please note:	Price without centering point
	Center distance [mm]:	57,5
8 263 19 010	Tool holder with rotating centering point	
	Weight [kg]:	8.160
	Notation:	180° reversible
	Shank type:	BMT
	Machine adaption:	Centering key b 20
	Rotation max [1/min]:	6000
	Coolant:	EXT
	Please note:	Taper roller bearings
	Center distance [mm]:	90
8 263 19 031	Tool holder with rotating centering point	
	Weight [kg]:	8.280
	Notation:	180° reversible
	Shank type:	BMT
	Machine adaption:	Centering key b 20
	Rotation max [1/min]:	6000
	Coolant:	EXT
	Please note:	Taper roller bearings
	Center distance [mm]:	90
8 269 19 001	Tool holder with rotating centering point	
	Weight [kg]:	8.510
	Notation:	180° reversible
	Version:	Special; double spindle
	Shank type:	BMT
	Machine adaption:	Centering key b 20
	Rotation max [1/min]:	6000
	Coolant:	EXT
	Please note:	Taper roller bearings
	Center distance [mm]:	90

Part-#	Name	
8 269 19 002	Tool holder with rotating centering point	
	Weight [kg]:	8.380
	Notation:	180° reversible
	Version:	Special; double spindle
	Shank type:	BMT
	Machine adaption:	Centering key b 20
	Rotation max [1/min]:	6000
	Coolant:	EXT
	Please note:	Taper roller bearings
	Center distance [mm]:	90
8 320 13 004	Cut-off holder, height adjustable SH 32 IC	
	Weight [kg]:	1.830
	Notation:	180° reversible
	Shank type:	BMT
	Machine adaption:	Centering key b 20
	Tool adaption:	Clampshaft SH 32
	Coolant:	IC/Ext
	Pressure max [bar]:	70
8 320 13 016	Cut-off holder, height adjustable SH 32 IC	
	Weight [kg]:	2.050
	Notation:	180° reversible
	Shank type:	BMT
	Machine adaption:	Centering key b 20
	Tool adaption:	Clampshaft SH 32
	Coolant:	IC/Ext
	Pressure max [bar]:	70
	Please note:	with offset cut-off tool holder use
8 320 13 017	Cut-off holder, height adjustable SH 32 IC	
	Weight [kg]:	1.960
	Notation:	180° reversible
	Shank type:	BMT
	Machine adaption:	Centering key b 20
	Tool adaption:	Clampshaft SH 32
	Coolant:	IC/Ext
	Pressure max [bar]:	70
	Please note:	Clampshaft internal
8 320 19 002	Cut-off holder, height adjustable 845 IC	
	Weight [kg]:	1.740
	Notation:	180° reversible
	Shank type:	BMT
	Machine adaption:	Centering key b 20
	Tool adaption:	 System 845
	Coolant:	IC
	Pressure max [bar]:	70
8 320 19 017	Cut-off holder, height adjustable 845 IC	
	Notation:	180° reversible
	Shank type:	BMT
	Machine adaption:	Centering key b 20
	Tool adaption:	 System 845
	Coolant:	IC
	Pressure max [bar]:	70
	Please note:	Clampshaft internal

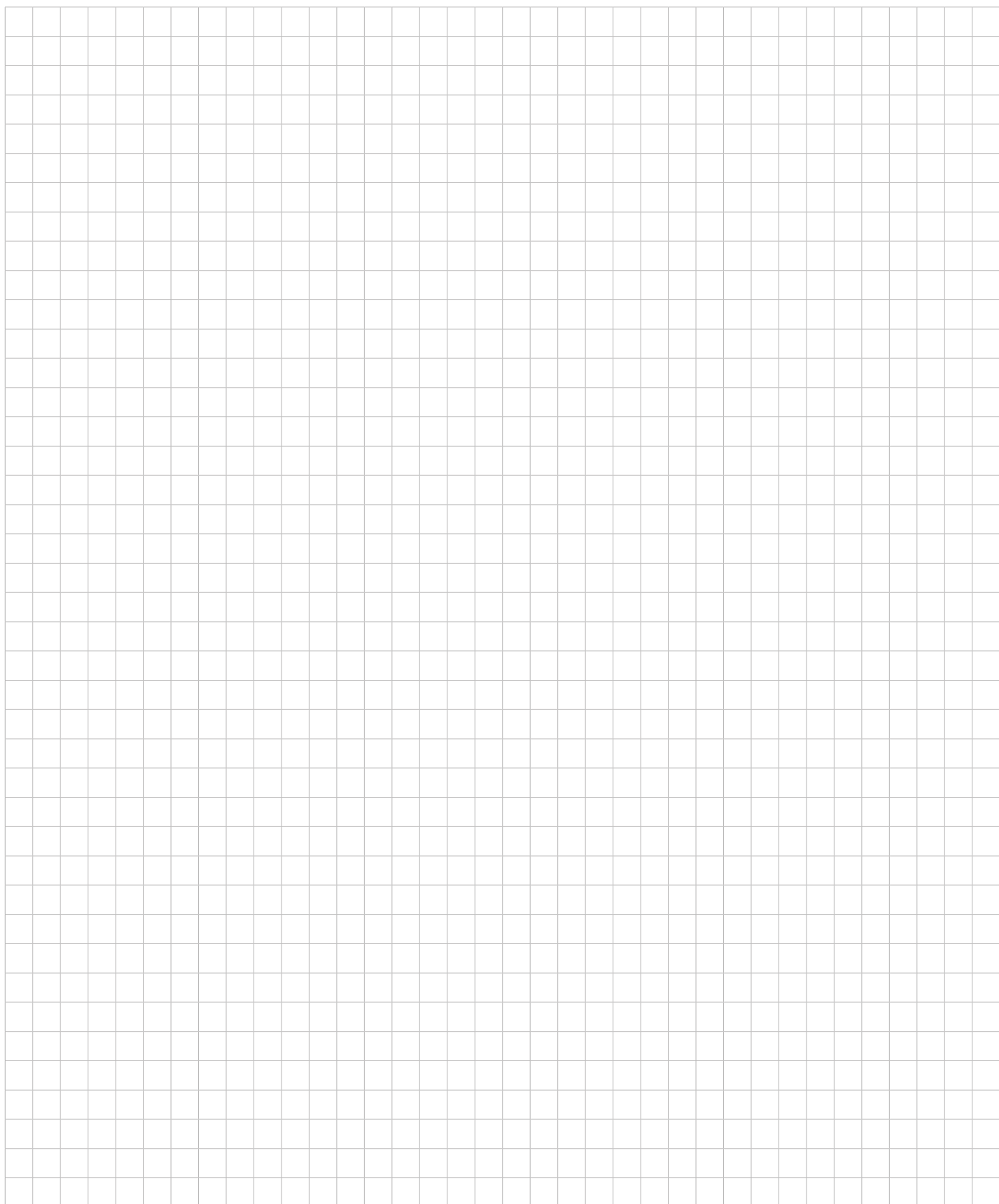

heimatec.u-tec®

heimatec.com

Products / Tool change systems /
u-tec® Tool-changing system



versions see catalog

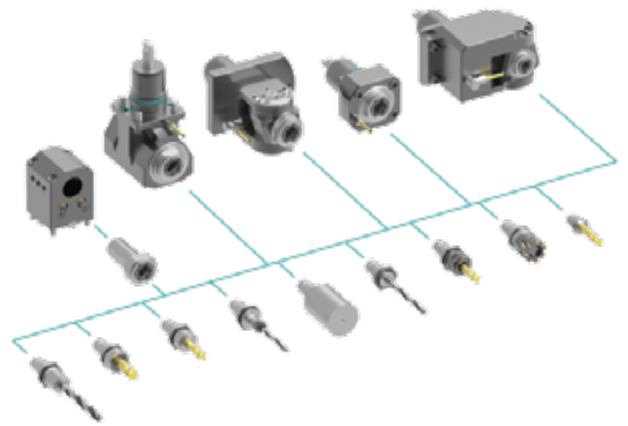

heimatec.easy-quick

heimatec.com

Products / Tool change systems /
easy-quick HT quick-changing system



versions see catalog

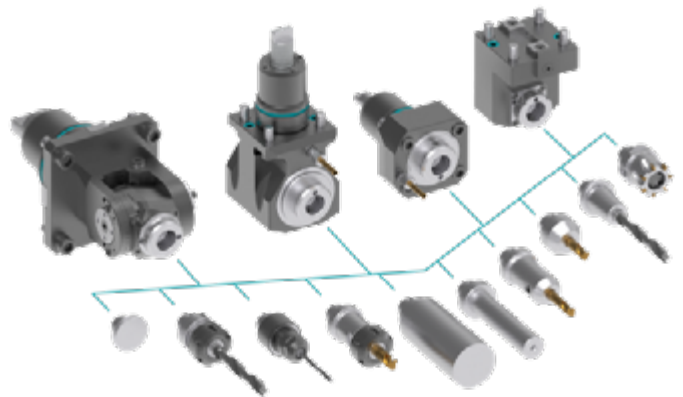

heimatec.Capto™

heimatec.com

Products / Tool change systems /
heimatec.Capto™ quick-changing system



versions see catalog

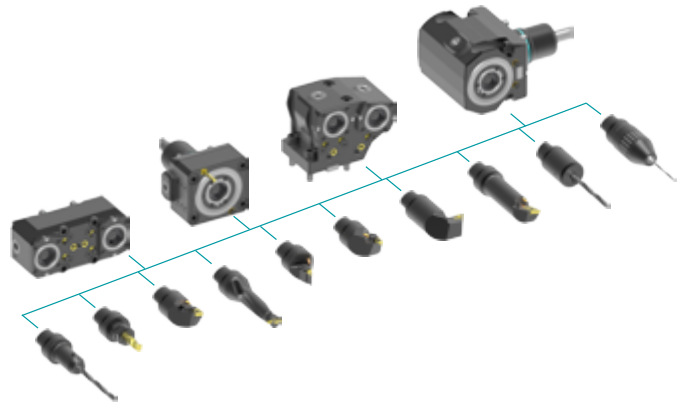

heimatec.accessories

heimatec.com

Products / Accessories



versions see catalog





● heimatec overseas branches

○ global representations of heimatec

heimatec[®]

heimatec GmbH
Präzisionswerkzeuge
Carl-Benz-Str. 4
77871 Renchen
Germany

T +49 7843 9466 0
www.heimatec.com
info@heimatec.com

Please find the contact details of our worldwide trading partners on our website:
<https://heimatec.com/business-partners>