

Emco

ET 420 TCM



High-tech from heimatec - heimatec - Tools and systems for productive turning and milling

heimatec belongs to the international technology and quality leaders for precision tools and specializes in the development and production of high-precision static and live tools for all CNC lathes, CNC turn-/mill machines and CNC machining centers.

The range of products* spans from static BMT and VDI tool holders, live tools up to highly complex customer-specific individual solutions. heimatec, headquartered in Renchen, has a own subsidiary in Asia and India and numerous representatives as well as trading partners all over the world.

*OUR PRODCUTS

Static tool holders

Live tool units

Precision tools

Tools for turning and machining centres

Tools for swiss type lathes

Tool changing and uick-change systems

Tool systems for gear production

Digital tool management

This catalogue, including all its parts, is protected by copyright. Any use outside the restricted limitations of the Copyright Act without the consent of heimatec is inadmissible and liable to prosecution. This applies in particular to duplication, translation, microfilming and storage and processing in electronic systems.

heimatec GmbH reserves the right to make technical changes at any time without giving prior notice. This applies in particular to adjustments at any time to meet new or changed international standards, or in case of further developments of our products or manufacturing processes.

The current version of our General Terms and Conditions can be found on our website.

Part-#	Name	
8 009 33 000	Adapter as extension	
	Tool drive:	Key slot
	Shank type:	BMT
	Machine adaption:	Centering bore Ø 38
	Tool adaption:	Center 38
	Gear ratio [i]:	1:1
	Torque max [Nm]:	10
	Rotation max [1/min]:	8000
	Rotating direction:	same
	Coolant:	no
8 009 33 001	Adapter as extension	
	Weight [kg]:	0.540
	Tool drive:	Key slot
	Shank type:	BMT
	Machine adaption:	Centering bore Ø 38
	Tool adaption:	Center 38
	Gear ratio [i]:	1:1
	Torque max [Nm]:	10
	Rotation max [1/min]:	8000
	Rotating direction:	same
	Coolant:	no
8 010 34 000	Axial drilling and milling head ER 16	
	Weight [kg]:	0.560
	Tool drive:	Key slot
	Shank type:	BMT
	Machine adaption:	Centering bore Ø 38
	Tool adaption:	ER 16
	Gear ratio [i]:	1:1
	Torque max [Nm]:	10
	Rotation max [1/min]:	8000
	Rotating direction:	same
8 011 34 000	Axial milling head universal arbor 16	
	Tool drive:	Key slot
	Shank type:	BMT
	Machine adaption:	Centering bore Ø 38
	Tool adaption:	Universal arbor 16
	Gear ratio [i]:	1:1
	Torque max [Nm]:	10
	Rotation max [1/min]:	8000
	Rotating direction:	same
8 011 34 001	Axial milling head universal arbor 16	
	Weight [kg]:	0.780
	Tool drive:	Key slot
	Shank type:	BMT
	Machine adaption:	Centering bore Ø 38
	Tool adaption:	Universal arbor 16
	Gear ratio [i]:	1:1
	Torque max [Nm]:	10
	Rotation max [1/min]:	8000
	Rotating direction:	same

Part-#	Name	
8 030 34 000	Radial drilling and milling head ER 16	
	Weight [kg]:	2.000
	Tool drive:	Key slot
	Shank size [mm]:	38.00
	Shank type:	BMT
	Machine adaption:	Centering bore Ø 38
	Tool adaption:	ER 16
	Gear ratio [i]:	1:1
	Torque max [Nm]:	10
	Rotation max [1/min]:	6000
	Rotating direction:	opposite
8 030 34 002	Radial drilling and milling head ER 20	
	Weight [kg]:	1.700
	Tool drive:	Key slot
	Shank type:	BMT
	Machine adaption:	Centering bore Ø 38
	Tool adaption:	ER 20
	Gear ratio [i]:	1:1
	Torque max [Nm]:	10
	Rotation max [1/min]:	6000
	Rotating direction:	opposite
8 039 34 000	Radial drilling and milling head ER 16	
	Weight [kg]:	1.800
	Version:	double spindle
	Tool drive:	Key slot
	Shank type:	BMT
	Machine adaption:	Centering bore Ø 38
	Tool adaption:	ER 16
	Gear ratio [i]:	1:1
	Torque max [Nm]:	10
	Rotation max [1/min]:	5000
	Rotating direction:	same/opposite
8 040 33 000	Universal head ± 90° adjustable ER 11 AX	
	Tool drive:	Key slot
	Shank type:	BMT
	Machine adaption:	Centering bore Ø 38
	Tool adaption:	ER 11 A
	Gear ratio [i]:	1:1
	Torque max [Nm]:	10
	Rotation max [1/min]:	6300
	Rotating direction:	same
	Coolant:	EXT
	Please note:	Tool length with 0-position max. 8mm





heimatec.u-tec®

heimatec.com

Products / Tool change systems /
u-tec® Tool-changing system



versions see catalog



heimatec.easy-quick

heimatec.com

Products / Tool change systems /
easy-quick HT quick-changing system



versions see catalog



heimatec.Capto™

heimatec.com

Products / Tool change systems /
heimatec.Capto™ quick-changing system



versions see catalog

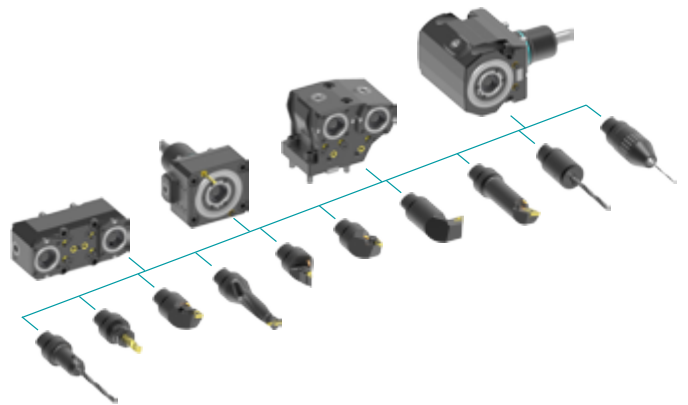

heimatec.accessories

heimatec.com

Products / Accessories



versions see catalog





● heimatec overseas branches

○ global representations of heimatec

heimatec[®]

heimatec GmbH
Präzisionswerkzeuge
Carl-Benz-Str. 4
77871 Renchen
Germany

T +49 7843 9466 0
www.heimatec.com
info@heimatec.com

Please find the contact details of our worldwide trading partners on our website:
<https://heimatec.com/business-partners>