

ER-Hydrospannzange



für heimatec Standardwerkzeuge



ER-Hydrospannzange

Artikel-Nr.	Spannsystem D	Gewinde G	d ₁ [mm]	d ₂ [mm]	L [mm]	l ₁ [mm]	l ₂ [mm]
ER 16-HYDRO.030	ER 16	M 24x1,0	3	36	43,7	22,5	11,5
ER 16-HYDRO.040			4	36	43,7	22,5	11,5
ER 16-HYDRO.050			5	36	43,7	22,5	11,5
ER 16-HYDRO.060			6	36	45,7	24,5	13,5
ER 16-HYDRO.080			8	36	45,7	24,5	13,5
ER 20-HYDRO.030	ER 20	M 28x1,5	3	38	48,3	24	13
ER 20-HYDRO.040			4	38	48,3	24	13
ER 20-HYDRO.050			5	38	48,3	24	13
ER 20-HYDRO.060			6	38	48,3	24	13
ER 20-HYDRO.080			8	38	48,3	24	13
ER 20-HYDRO.100			10	40	48,3	24	13
ER 25-HYDRO.050	ER 25	M 32x1,5	5	40	51	24,5	12
ER 25-HYDRO.060			6	40	51	24,5	12
ER 25-HYDRO.070			7	40	51	24,5	12
ER 25-HYDRO.080			8	40	51	24,5	12
ER 25-HYDRO.100			10	40	51	24,5	12
ER 25-HYDRO.120			12	42	51	24,5	12
ER 25-HYDRO.140			14	44	51	24,5	12
ER 25-HYDRO.160			16	46	49	26,5	14
ER 32-HYDRO.060	ER 32	M 40x1,5	6	50	58,3	26,5	12
ER 32-HYDRO.080			8	50	58,3	26,5	12
ER 32-HYDRO.100			10	50	58,3	26,5	12
ER 32-HYDRO.120			12	50	58,3	26,5	12
ER 32-HYDRO.140			14	50	58,3	26,5	12
ER 32-HYDRO.160			16	50	58,3	26,5	12
ER 32-HYDRO.180			18	50	58,3	26,5	12
ER 32-HYDRO.200	20	50	58,3	26,5	12		
ER 40-HYDRO.160	ER 40	M 50x1,5	16	63	72	36,5	20,5
ER 40-HYDRO.200			20	63	72	36,5	20,5
ER 40-HYDRO.250			25	63	72	36,5	20,5
ER 16-HYDRO.0317	ER 16	M 24x1,0	1/8"	36	43,7	22,5	11,5
ER 16-HYDRO.0635			1/4"	36	45,7	24,5	13,5

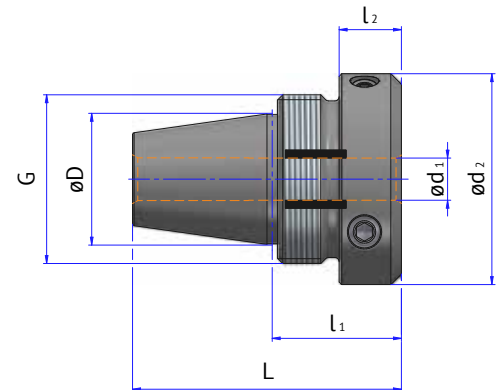

Vorteile:

- hohe Flexibilität
- gleichbleibender Spindelrundlauf
- Kegel zu Kegel zentriert sich nahezu auf null
- Dämpfung durch Hydrodehn

Zubehör

Reduzierbuchse

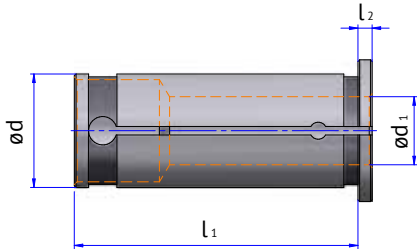

Artikel-Nr.	d [mm]	d ₁ [mm]	l ₁ [mm]	l ₂ [mm]
8 669 01 000	12	3	44,0	2,0
8 669 02 000	12	4	44,0	2,0
8 669 02 002	12	5	44,0	2,0
8 669 02 001	12	6	44,0	2,0
8 669 03 000	12	8	44,0	2,0
8 669 11 000	20	3	50,0	2,5
8 669 12 001	20	4	50,0	2,5
8 669 12 002	20	5	50,0	2,5
8 669 12 000	20	6	50,0	2,5
8 669 13 000	20	8	50,0	2,5
8 669 14 002	20	10	50,0	2,5
8 669 14 000	20	12	50,0	2,5
8 669 14 001	20	14	50,0	2,5
8 669 15 000	20	16	50,0	2,5
8 669 22 001	25	5	57,0	2,5
8 669 22 000	25	6	57,0	2,5
8 669 23 000	25	8	57,0	2,5
8 669 24 004	25	10	57,0	2,5
8 669 24 002	25	12	57,0	2,5
8 669 24 003	25	14	57,0	2,5
8 669 25 000	25	16	57,0	2,5
8 669 25 001	25	18	57,0	2,5
8 669 26 000	25	20	57,0	2,5

Gelenk-Stirnlochschlüssel

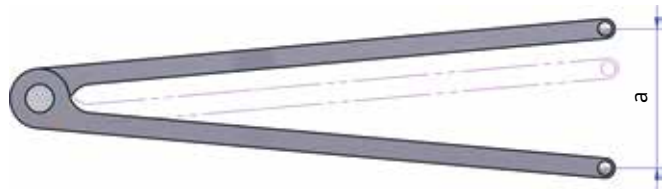

Artikel-Nr.	Spannweite a [mm]	Zapfen ø [mm]	Gesamtlänge [mm]
1 655 011 003	14 - 100	5,0	215,0

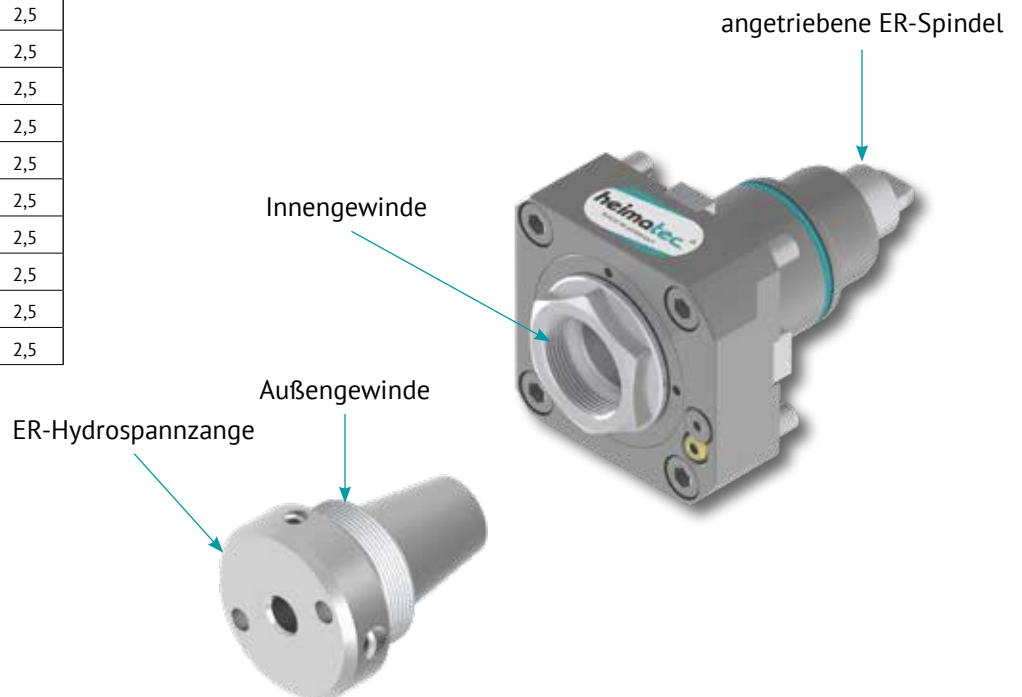
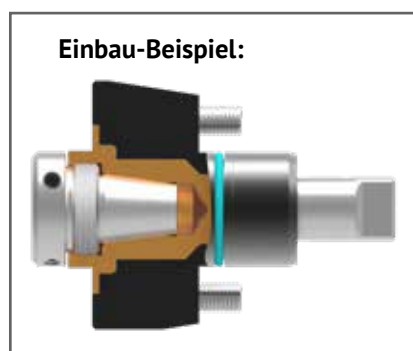



● heimatec®-Niederlassungen

○ unsere weltweiten Vertretungen

heimatec®

heimatec GmbH
Präzisionswerkzeuge
Carl-Benz-Str. 4
DE-77871 Renchen

T +49 7843 9466 0
F +49 7843 9466 66
www.heimatec.de
info@heimatec.de

Die Kontaktdaten unserer weltweiten Handelspartner finden Sie auf unserer Internetseite:
<https://heimatec.com/handelspartner>