

Nakamura  
**WT-300 Ø 65/71**  
**Std.**



# High-tech from heimatec - heimatec - Tools and systems for productive turning and milling

heimatec belongs to the international technology and quality leaders for precision tools and specializes in the development and production of high-precision static and live tools for all CNC lathes, CNC turn-/mill machines and CNC machining centers.

The range of products\* spans from static BMT and VDI tool holders, live tools up to highly complex customer-specific individual solutions. heimatec, headquartered in Renchen, has a own subsidiary in Asia and India and numerous representatives as well as trading partners all over the world.

## \*OUR PRODCUTS

Static tool holders

Live tool units

Precision tools

Tools for turning and machining centres

Tools for swiss type lathes

Tool changing and uick-change systems

Tool systems for gear production

Digital tool management

This catalogue, including all its parts, is protected by copyright. Any use outside the restricted limitations of the Copyright Act without the consent of heimatec is inadmissible and liable to prosecution. This applies in particular to duplication, translation, microfilming and storage and processing in electronic systems.



**heimatec GmbH** reserves the right to make technical changes at any time without giving prior notice. This applies in particular to adjustments at any time to meet new or changed international standards, or in case of further developments of our products or manufacturing processes.

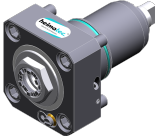

The current version of our General Terms and Conditions can be found on our website.

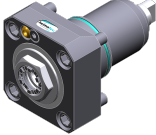
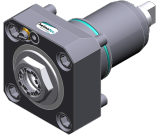
Part-#	Name	
<b>8 010 64 003</b>	<b>Axial drilling and milling head Weldon 12 IC</b>	
	Tool drive:	Flat (~DIN 1809)
	Shank size [mm]:	65.00
	Shank type:	BMT
	Tool adaption:	Weldon (DIN 1835 b) 12
	Gear ratio [i]:	1:1
	Torque max [Nm]:	50
	Rotation max [1/min]:	6000
	Rotating direction:	same
	Coolant:	IC/Ext
	Pressure max [bar]:	25
<b>8 010 64 005</b>	<b>Axial drilling and milling head Weldon 12</b>	
	Tool drive:	Flat (~DIN 1809)
	Shank size [mm]:	65.00
	Shank type:	BMT
	Tool adaption:	Weldon (DIN 1835 b) 12
	Gear ratio [i]:	1:1
	Torque max [Nm]:	50
	Rotation max [1/min]:	6000
	Rotating direction:	same
	Coolant:	EXT
<b>8 010 64 006</b>	<b>Axial drilling and milling head Weldon 14 IC</b>	
	Tool drive:	Flat (~DIN 1809)
	Shank size [mm]:	65.00
	Shank type:	BMT
	Tool adaption:	Weldon (DIN 1835 b) 14
	Gear ratio [i]:	1:1
	Torque max [Nm]:	50
	Rotation max [1/min]:	6000
	Rotating direction:	same
	Coolant:	IC/Ext
<b>8 010 65 005</b>	<b>Axial drilling and milling head Weldon 16</b>	
	Weight [kg]:	2.920
	Tool drive:	Flat (~DIN 1809)
	Shank size [mm]:	65.00
	Shank type:	BMT
	Tool adaption:	Weldon (DIN 1835 b) 16
	Gear ratio [i]:	1:1
	Torque max [Nm]:	50
	Rotation max [1/min]:	6000
	Rotating direction:	same
	Coolant:	EXT
<b>8 010 65 006</b>	<b>Axial drilling and milling head Weldon 16 IC</b>	
	Tool drive:	Flat (~DIN 1809)
	Shank size [mm]:	65.00
	Shank type:	BMT
	Tool adaption:	Weldon (DIN 1835 b) 16
	Gear ratio [i]:	1:1
	Torque max [Nm]:	50
	Rotation max [1/min]:	6000
	Rotating direction:	same
	Coolant:	IC/Ext
	Pressure max [bar]:	25

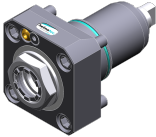
Part-#	Name	
<b>8 010 65 017</b>	<b>Axial drilling and milling head ER 25 AX UT IC</b>	
	Weight [kg]:	2.800
	Tool drive:	Flat (~DIN 1809)
	Shank size [mm]:	65.00
	Shank type:	BMT
	Tool adaption:	ER 25 A - u-tec
	Gear ratio [i]:	1:1
	Torque max [Nm]:	50
	Rotation max [1/min]:	6000
	Rotating direction:	same
	Coolant:	IC/Ext
	Pressure max [bar]:	25
	Please note:	stronger bearing
<b>8 010 65 020</b>	<b>Axial drilling and milling head ER 25 AX UT IC</b>	
	Weight [kg]:	2.700
	Tool drive:	Flat (~DIN 1809)
	Shank size [mm]:	65.00
	Shank type:	BMT
	Tool adaption:	ER 25 A - u-tec
	Gear ratio [i]:	1:1
	Torque max [Nm]:	50
	Rotation max [1/min]:	6000
	Rotating direction:	same
	Coolant:	IC/Ext
	Pressure max [bar]:	25
<b>8 010 65 021</b>	<b>Axial drilling and milling head ER 25 AX UT</b>	
	Weight [kg]:	2.670
	Tool drive:	Flat (~DIN 1809)
	Shank size [mm]:	65.00
	Shank type:	BMT
	Tool adaption:	ER 25 A - u-tec
	Gear ratio [i]:	1:1
	Torque max [Nm]:	50
	Rotation max [1/min]:	6000
	Rotating direction:	same
	Coolant:	EXT
<b>8 010 65 022</b>	<b>Axial milling and drill holder ER 25 AX UT IC</b>	
	Tool drive:	Flat (~DIN 1809)
	Shank size [mm]:	65.00
	Shank type:	BMT
	Tool adaption:	ER 25 A - u-tec
	Gear ratio [i]:	1:1
	Torque max [Nm]:	50
	Rotation max [1/min]:	5000
	Rotating direction:	same
	Coolant:	IC/Ext
	Pressure max [bar]:	100
	Please note:	Combi bearing; dryrun possible

Part-#	Name	
	<b>8 010 65 023</b>	<b>Axial milling and drill holder ER 25 AX UT</b>
		Weight [kg]: 3.950 Tool drive: Flat (~DIN 1809) Shank size [mm]: 65.00 Shank type: BMT Tool adaption: ER 25 A - u-tec Gear ratio [i]: 1:1 Torque max [Nm]: 50 Rotation max [1/min]: 5000 Rotating direction: same Coolant: EXT Please note: Combi bearing
	<b>8 010 65 038</b>	<b>Axial drilling and milling head ER 25 AX UT IC</b>
		Tool drive: Flat (~DIN 1809) Shank size [mm]: 65.00 Shank type: BMT Tool adaption: ER 25 A - u-tec Gear ratio [i]: 1:1 Torque max [Nm]: 50 Rotation max [1/min]: 5000 Rotating direction: same Coolant: IC/Ext Pressure max [bar]: 100 Please note: Dryrun possible
	<b>8 010 66 002</b>	<b>Axial drilling and milling head ER 32 IC</b>
		Weight [kg]: 2.920 Tool drive: Flat (~DIN 1809) Shank size [mm]: 65.00 Shank type: BMT Tool adaption: ER 32 Gear ratio [i]: 1:1 Torque max [Nm]: 50 Rotation max [1/min]: 6000 Rotating direction: same Coolant: IC/Ext Pressure max [bar]: 25
	<b>8 010 66 003</b>	<b>Axial drilling and milling head ER 32</b>
		Weight [kg]: 2.880 Tool drive: Flat (~DIN 1809) Shank size [mm]: 65.00 Shank type: BMT Tool adaption: ER 32 Gear ratio [i]: 1:1 Torque max [Nm]: 50 Rotation max [1/min]: 6000 Rotating direction: same Coolant: EXT

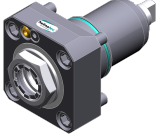
Part-#	Name	
<b>8 010 66 017</b>	<b>Axial drilling and milling head HT 4</b>	
	Weight [kg]:	2.860
	Tool drive:	Flat (~DIN 1809)
	Shank size [mm]:	65.00
	Shank type:	BMT
	Tool adaption:	HT 4
	Gear ratio [i]:	1:1
	Torque max [Nm]:	50
	Rotation max [1/min]:	6000
	Rotating direction:	same
	Coolant:	EXT
	Please note:	stronger bearing
<b>8 010 66 043</b>	<b>Axial drilling and milling head ER 32 IC</b>	
	Weight [kg]:	3.000
	Tool drive:	Flat (~DIN 1809)
	Shank size [mm]:	65.00
	Shank type:	BMT
	Tool adaption:	ER 32
	Gear ratio [i]:	1:1
	Torque max [Nm]:	50
	Rotation max [1/min]:	6000
	Rotating direction:	same
	Coolant:	IC/Ext
	Pressure max [bar]:	25
	Please note:	stronger bearing
<b>8 010 66 050</b>	<b>Axial milling and drill holder ER 32 AX UT</b>	
	Weight [kg]:	3.920
	Tool drive:	Flat (~DIN 1809)
	Shank size [mm]:	65.00
	Shank type:	BMT
	Tool adaption:	ER 32 A - u-tec
	Gear ratio [i]:	1:1
	Torque max [Nm]:	50
	Rotation max [1/min]:	5000
	Rotating direction:	same
	Coolant:	EXT
	Please note:	Combi bearing
<b>8 010 66 067</b>	<b>Axial milling and drill holder ER 32 AX UT IC</b>	
	Weight [kg]:	4.030
	Tool drive:	Flat (~DIN 1809)
	Shank size [mm]:	65.00
	Shank type:	BMT
	Tool adaption:	ER 32 A - u-tec
	Gear ratio [i]:	1:1
	Torque max [Nm]:	50
	Rotation max [1/min]:	5000
	Rotating direction:	same
	Coolant:	IC/Ext
	Pressure max [bar]:	100
	Please note:	Combi bearing; Trockenauf possible

Part-#	Name	
	<b>8 010 66 126</b>	<b>Axial drilling and milling head ER 32 AX UT</b>
	Weight [kg]:	4.080
	Tool drive:	Flat (~DIN 1809)
	Shank size [mm]:	65.00
	Shank type:	BMT
	Tool adaption:	ER 32 A - u-tec
	Gear ratio [i]:	1:1
	Torque max [Nm]:	50
	Rotation max [1/min]:	6000
	Rotating direction:	same
Coolant:	EXT	
	<b>8 010 66 127</b>	<b>Axial drilling and milling head ER 32 AX UT IC</b>
	Weight [kg]:	4.000
	Tool drive:	Flat (~DIN 1809)
	Shank size [mm]:	65.00
	Shank type:	BMT
	Tool adaption:	ER 32 A - u-tec
	Gear ratio [i]:	1:1
	Torque max [Nm]:	50
	Rotation max [1/min]:	6000
	Rotating direction:	same
Coolant:	IC/Ext	
Pressure max [bar]:	100	
Please note:	Dryrun possible	
	<b>8 010 67 013</b>	<b>Axial drilling and milling head HT 5</b>
	Weight [kg]:	2.960
	Tool drive:	Flat (~DIN 1809)
	Shank size [mm]:	65.00
	Shank type:	BMT
	Tool adaption:	HT 5
	Gear ratio [i]:	1:1
	Torque max [Nm]:	50
	Rotation max [1/min]:	6000
	Rotating direction:	same
Coolant:	EXT	
Please note:	stronger bearing	
	<b>8 010 67 016</b>	<b>Axial drilling and milling head HT 5 IC</b>
	Weight [kg]:	2.990
	Tool drive:	Flat (~DIN 1809)
	Shank size [mm]:	65.00
	Shank type:	BMT
	Tool adaption:	HT 5
	Gear ratio [i]:	1:1
	Torque max [Nm]:	50
	Rotation max [1/min]:	6000
	Rotating direction:	same
Coolant:	IC/Ext	
Pressure max [bar]:	25	
Please note:	stronger bearing	

Part-#	Name	
<b>8 010 67 024</b>	<b>Axial drilling and milling head HT 5 IC</b>	
	Tool drive:	Flat (~DIN 1809)
	Shank size [mm]:	65.00
	Shank type:	BMT
	Tool adaption:	HT 5
	Gear ratio [i]:	1:1
	Torque max [Nm]:	50
	Rotation max [1/min]:	6000
	Rotating direction:	same
	Coolant:	IC/Ext
	Pressure max [bar]:	25
<b>8 010 67 029</b>	<b>Axial drilling and milling head HT 5 IC</b>	
	Weight [kg]:	2.960
	Tool drive:	Flat (~DIN 1809)
	Shank size [mm]:	65.00
	Shank type:	BMT
	Tool adaption:	HT 5
	Gear ratio [i]:	1:1
	Torque max [Nm]:	50
	Rotation max [1/min]:	6000
	Rotating direction:	same
	Coolant:	IC/Ext
	Pressure max [bar]:	70
	Please note:	High pressure version
<b>8 010 67 054</b>	<b>Axial drilling and milling head ER 40 AX UT</b>	
	Tool drive:	Flat (~DIN 1809)
	Shank size [mm]:	65.00
	Shank type:	BMT
	Tool adaption:	ER 40 A - u-tec
	Gear ratio [i]:	1:1
	Torque max [Nm]:	50
	Rotation max [1/min]:	5000
	Rotating direction:	same
	Coolant:	EXT
	Please note:	Combi bearing
<b>8 010 67 062</b>	<b>Axial drilling and milling head Weldon 25 IC</b>	
	Weight [kg]:	4.140
	Tool drive:	Flat (~DIN 1809)
	Shank size [mm]:	65.00
	Shank type:	BMT
	Tool adaption:	Weldon (DIN 1835 b) 25
	Gear ratio [i]:	1:1
	Torque max [Nm]:	50
	Rotation max [1/min]:	5000
	Rotating direction:	same
	Coolant:	IC/Ext
	Pressure max [bar]:	25
	Please note:	Combi bearing

Part-#	Name
<b>8 010 67 127</b>	<b>Axial drilling and milling head ER 40 AX UT IC</b>
	Weight [kg]: 4.550
	Tool drive: Flat (~DIN 1809)
	Shank size [mm]: 65.00
	Shank type: BMT
	Tool adaption: ER 40 A - u-tec
	Gear ratio [i]: 1:1
	Torque max [Nm]: 50
	Rotation max [1/min]: 5000
	Rotating direction: same
	Coolant: IC/Ext
	Pressure max [bar]: 25
	Please note: Combi bearing
<b>8 010 67 128</b>	<b>Axial drilling and milling head ER 40 AX UT</b>
	Weight [kg]: 4.620
	Tool drive: Flat (~DIN 1809)
	Shank size [mm]: 65.00
	Shank type: BMT
	Tool adaption: ER 40 A - u-tec
	Gear ratio [i]: 1:1
	Torque max [Nm]: 50
	Rotation max [1/min]: 12000
	Rotating direction: same
	Coolant: EXT
	Pressure max [bar]: 140
<b>8 011 64 003</b>	<b>Axial milling head universal arbor 3/4"</b>
	Weight [kg]: 3.800
	Tool drive: Flat (~DIN 1809)
	Shank size [mm]: 65.00
	Shank type: BMT
	Tool adaption: Universal arbor 3/4" (19,05mm)
	Gear ratio [i]: 1:1
	Torque max [Nm]: 50
	Rotation max [1/min]: 6000
	Rotating direction: same
	Coolant: EXT
	Please note: Taper roller bearings
<b>8 011 64 004</b>	<b>Axial milling head universal arbor 16</b>
	Weight [kg]: 4.110
	Tool drive: Flat (~DIN 1809)
	Shank size [mm]: 65.00
	Shank type: BMT
	Tool adaption: Universal arbor 16
	Gear ratio [i]: 1:1
	Torque max [Nm]: 50
	Rotation max [1/min]: 5000
	Rotating direction: same
	Coolant: EXT
	Please note: Combi bearing

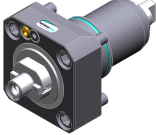

Part-#	Name		
	<b>8 011 64 006</b>	<b>Axial milling head universal arbor 3/4"</b>	
		Weight [kg]:	4.060
		Tool drive:	Flat (~DIN 1809)
		Shank size [mm]:	65.00
		Shank type:	BMT
		Tool adaption:	Universal arbor 3/4" (19,05mm)
		Gear ratio [i]:	1:1
		Torque max [Nm]:	50
		Rotation max [1/min]:	6000
		Rotating direction:	same
		Coolant:	EXT
	Please note:	Combi bearing; without cutter retaining screw	
	<b>8 011 65 013</b>	<b>Axial milling head universal arbor 22</b>	
		Weight [kg]:	4.210
		Tool drive:	Flat (~DIN 1809)
		Shank size [mm]:	65.00
		Shank type:	BMT
		Tool adaption:	Universal arbor 22
		Gear ratio [i]:	1:1
		Torque max [Nm]:	50
		Rotation max [1/min]:	5000
		Rotating direction:	same
		Coolant:	EXT
	Please note:	Combi bearing	
	<b>8 011 66 004</b>	<b>Axial milling head universal arbor 27</b>	
		Tool drive:	Flat (~DIN 1809)
		Shank size [mm]:	65.00
		Shank type:	BMT
		Tool adaption:	Universal arbor 27
		Gear ratio [i]:	1:1
		Torque max [Nm]:	50
		Rotation max [1/min]:	6000
		Rotating direction:	same
		Coolant:	EXT
		Please note:	Taper roller bearings
	<b>8 011 66 009</b>	<b>Axial milling head universal arbor 27</b>	
		Tool drive:	Flat (~DIN 1809)
		Shank size [mm]:	65.00
		Shank type:	BMT
		Tool adaption:	Universal arbor 27
		Gear ratio [i]:	1:1
		Torque max [Nm]:	50
		Rotation max [1/min]:	5000
		Rotating direction:	same
		Coolant:	EXT
		Please note:	Combi bearing
	<b>8 011 67 002</b>	<b>Axial milling head universal arbor 32</b>	
		Tool drive:	Flat (~DIN 1809)
		Shank size [mm]:	65.00
		Shank type:	BMT
		Tool adaption:	Universal arbor 32
		Torque max [Nm]:	50

Part-#	Name	
	Rotation max [1/min]:	4000
	Rotating direction:	same
	Coolant:	EXT
	Please note:	Taper roller bearings
<b>8 013 64 002</b>	<b>Axial drilling and milling head ER 16 AX UT</b>	
	Weight [kg]:	3.500
	Tool drive:	Flat (~DIN 1809)
	Shank size [mm]:	65.00
	Shank type:	BMT
	Tool adaption:	ER 16 A - u-tec
	Gear ratio [i]:	1:4
	Torque max [Nm]:	5
	Rotation max [1/min]:	24000
	Rotating direction:	same
	Coolant:	EXT
<b>8 013 65 002</b>	<b>Axial drilling and milling head ER 25 AC IC</b>	
	Tool drive:	Flat (~DIN 1809)
	Shank size [mm]:	65.00
	Shank type:	BMT
	Tool adaption:	ER 25 A
	Gear ratio [i]:	2:1
	Torque max [Nm]:	80
	Rotation max [1/min]:	2000
	Rotating direction:	same
	Coolant:	IC/Ext
	Pressure max [bar]:	25
<b>8 014 65 000</b>	<b>Axial milling head universal arbor 22</b>	
	Weight [kg]:	7.900
	Tool drive:	Flat (~DIN 1809)
	Shank size [mm]:	65.00
	Shank type:	BMT
	Tool adaption:	Universal arbor 22
	Gear ratio [i]:	2:1
	Torque max [Nm]:	80
	Rotation max [1/min]:	2000
	Rotating direction:	same
	Coolant:	EXT
<b>8 019 65 006</b>	<b>Axial drilling and milling head ER 25 AX UT</b>	
	Weight [kg]:	6.820
	Notation:	offset; 180° reversible
	Tool drive:	Flat (~DIN 1809)
	Shank size [mm]:	65.00
	Shank type:	BMT
	Tool adaption:	ER 25 A - u-tec
	Gear ratio [i]:	1:3
	Torque max [Nm]:	12
	Rotation max [1/min]:	15000
	Rotating direction:	opposite
	Coolant:	EXT
	Please note:	stronger bearing
	Offset [mm]:	50

Part-#	Name	
	<b>8 019 65 011</b>	<b>Axial drilling and milling head ER 25 AX UT IC</b>
	Weight [kg]:	8.080
	Notation:	offset; 180° reversible
	Tool drive:	Flat (~DIN 1809)
	Shank size [mm]:	65.00
	Shank type:	BMT
	Tool adaption:	ER 25 A - u-tec
	Gear ratio [i]:	1:1
	Torque max [Nm]:	50
	Rotation max [1/min]:	12000
	Rotating direction:	opposite
	Coolant:	IC/Ext
	Pressure max [bar]:	140
	Please note:	stronger bearing
Offset [mm]:	50	
	<b>8 030 62 000</b>	<b>Radial drilling and milling head Weldon 6</b>
	Weight [kg]:	8.160
	Tool drive:	Flat (~DIN 1809)
	Shank size [mm]:	65.00
	Shank type:	BMT
	Tool adaption:	Weldon (DIN 1835 b) 6
	Gear ratio [i]:	1:3
	Torque max [Nm]:	8
	Rotation max [1/min]:	15000
	Rotating direction:	opposite
	Coolant:	EXT
Center distance [mm]:	65	
	<b>8 030 63 000</b>	<b>Radial drilling and milling head Weldon 8 IC</b>
	Notation:	180° reversible
	Tool drive:	Flat (~DIN 1809)
	Shank size [mm]:	65.00
	Shank type:	BMT
	Tool adaption:	Weldon (DIN 1835 b) 8
	Gear ratio [i]:	1:1
	Torque max [Nm]:	50
	Rotation max [1/min]:	6000
	Rotating direction:	opposite
	Coolant:	IC/Ext
Pressure max [bar]:	25	
Center distance [mm]:	65	
	<b>8 030 64 014</b>	<b>Radial drilling and milling head Weldon 10 IC</b>
	Notation:	180° reversible
	Tool drive:	Flat (~DIN 1809)
	Shank size [mm]:	65.00
	Shank type:	BMT
	Tool adaption:	Weldon (DIN 1835 b) 10
	Gear ratio [i]:	1:1
	Torque max [Nm]:	50
	Rotation max [1/min]:	6000
	Rotating direction:	opposite
	Coolant:	IC/Ext
Pressure max [bar]:	140	
Please note:	Combi bearing	
Center distance [mm]:	65	

Part-#	Name	
<b>8 030 64 022</b>	<b>Radial drilling and milling head Weldon 12</b>	
	Notation:	180° reversible
	Tool drive:	Flat (~DIN 1809)
	Shank size [mm]:	65.00
	Shank type:	BMT
	Tool adaption:	Weldon (DIN 1835 b) 12
	Gear ratio [i]:	1:2
	Torque max [Nm]:	16
	Rotation max [1/min]:	12000
	Rotating direction:	same
	Coolant:	EXT
	Please note:	stronger bearing
	Center distance [mm]:	80
<b>8 030 65 010</b>	<b>Radial drilling and milling head ER 25</b>	
	Notation:	180° reversible
	Tool drive:	Flat (~DIN 1809)
	Shank size [mm]:	65.00
	Shank type:	BMT
	Tool adaption:	ER 25
	Gear ratio [i]:	1:3
	Torque max [Nm]:	12
	Rotation max [1/min]:	12000
	Rotating direction:	same
	Coolant:	EXT
	Please note:	stronger bearing
	Center distance [mm]:	75
<b>8 030 65 014</b>	<b>Radial drilling and milling head ER 25</b>	
	Weight [kg]:	8.200
	Tool drive:	Flat (~DIN 1809)
	Shank size [mm]:	65.00
	Shank type:	BMT
	Tool adaption:	ER 25
	Gear ratio [i]:	1:3
	Torque max [Nm]:	8
	Rotation max [1/min]:	15000
	Rotating direction:	opposite
	Coolant:	EXT
	Center distance [mm]:	65
<b>8 030 65 015</b>	<b>Radial drilling and milling head ER 25 IC</b>	
	Weight [kg]:	7.720
	Notation:	180° reversible
	Tool drive:	Flat (~DIN 1809)
	Shank size [mm]:	65.00
	Shank type:	BMT
	Tool adaption:	ER 25
	Gear ratio [i]:	1:3
	Torque max [Nm]:	8
	Rotation max [1/min]:	15000
	Rotating direction:	opposite
	Coolant:	IC/Ext
	Pressure max [bar]:	25
	Center distance [mm]:	65

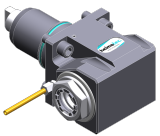
Part-#	Name	
<b>8 030 65 018</b>	<b>Radial drilling and milling head ER 25 IC</b>	
	Notation:	180° reversible
	Tool drive:	Flat (~DIN 1809)
	Shank size [mm]:	65.00
	Shank type:	BMT
	Tool adaption:	ER 25
	Gear ratio [i]:	1:1
	Torque max [Nm]:	50
	Rotation max [1/min]:	6000
	Rotating direction:	opposite
	Coolant:	IC/Ext
	Pressure max [bar]:	70
	Please note:	High pressure version
	Center distance [mm]:	65
<b>8 030 65 020</b>	<b>Radial drilling and milling head ER 25 AX UT IC</b>	
	Weight [kg]:	7.900
	Notation:	180° reversible
	Tool drive:	Flat (~DIN 1809)
	Shank size [mm]:	65.00
	Shank type:	BMT
	Tool adaption:	ER 25 A - u-tec
	Gear ratio [i]:	1:2
	Torque max [Nm]:	16
	Rotation max [1/min]:	12000
	Rotating direction:	same
	Coolant:	IC/Ext
	Pressure max [bar]:	140
	Please note:	stronger bearing
	Center distance [mm]:	80
<b>8 030 65 025</b>	<b>Radial drilling and milling head ER 25 IC</b>	
	Weight [kg]:	8.630
	Notation:	180° reversible
	Tool drive:	Flat (~DIN 1809)
	Shank size [mm]:	65.00
	Shank type:	BMT
	Tool adaption:	ER 25
	Gear ratio [i]:	1:3
	Torque max [Nm]:	12
	Rotation max [1/min]:	12000
	Rotating direction:	same
	Coolant:	IC
	Pressure max [bar]:	140
	Please note:	stronger bearing
	Center distance [mm]:	75
<b>8 030 65 046</b>	<b>Radial drilling and milling head Weldon 16</b>	
	Weight [kg]:	8.060
	Notation:	180° reversible
	Tool drive:	Flat (~DIN 1809)
	Shank size [mm]:	65.00
	Shank type:	BMT
	Tool adaption:	Weldon (DIN 1835 b) 16
	Gear ratio [i]:	1:1
	Torque max [Nm]:	50
	Rotation max [1/min]:	6000
	Rotating direction:	opposite

Part-#	Name	
	Coolant:	EXT
	Please note:	Combi bearing
	Center distance [mm]:	65
<b>8 030 66 001</b>	<b>Radial drilling and milling head Weldon 20 IC</b>	
	Weight [kg]:	8.400
	Notation:	180° reversible
	Tool drive:	Flat (~DIN 1809)
	Shank size [mm]:	65.00
	Shank type:	BMT
	Tool adaption:	Weldon (DIN 1835 b) 20
	Gear ratio [i]:	1:1
	Torque max [Nm]:	50
	Rotation max [1/min]:	6000
	Rotating direction:	opposite
	Coolant:	IC/Ext
	Pressure max [bar]:	25
	Please note:	stronger bearing
	Center distance [mm]:	65
<b>8 030 66 004</b>	<b>Radial drilling and milling head Weldon 20 IC</b>	
	Notation:	180° reversible
	Tool drive:	Flat (~DIN 1809)
	Shank size [mm]:	65.00
	Shank type:	BMT
	Tool adaption:	Weldon (DIN 1835 b) 20
	Gear ratio [i]:	1,625:1
	Torque max [Nm]:	63
	Rotation max [1/min]:	6000
	Rotating direction:	opposite
	Coolant:	IC/Ext
	Pressure max [bar]:	25
	Please note:	stronger bearing
	Center distance [mm]:	65
<b>8 030 66 078</b>	<b>Angle-mill- and drill holder ER 32 AX UT</b>	
	Weight [kg]:	8.340
	Notation:	180° reversible
	Tool drive:	Flat (~DIN 1809)
	Shank size [mm]:	65.00
	Shank type:	BMT
	Tool adaption:	ER 32 A - u-tec
	Gear ratio [i]:	1:1
	Torque max [Nm]:	50
	Rotation max [1/min]:	6000
	Rotating direction:	opposite
	Coolant:	EXT
	Please note:	Combi bearing
	Center distance [mm]:	65
<b>8 030 66 090</b>	<b>Angle-mill- and drill holder ER 32 AX UT IC</b>	
	Weight [kg]:	8.240
	Notation:	180° reversible
	Tool drive:	Flat (~DIN 1809)
	Shank size [mm]:	65.00
	Shank type:	BMT
	Tool adaption:	ER 32 A - u-tec

Part-#	Name
--------	------

Gear ratio [i]:	1:1
Torque max [Nm]:	50
Rotation max [1/min]:	6000
Rotating direction:	opposite
Coolant:	IC/Ext
Pressure max [bar]:	140
Please note:	Combi bearing
Center distance [mm]:	65

**8 030 66 103 Radial drilling and milling head ER 32 AX UT**

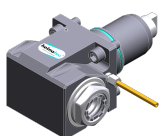

Notation:	180° reversible
Tool drive:	Flat (~DIN 1809)
Shank size [mm]:	65.00
Shank type:	BMT
Tool adaption:	ER 32 A - u-tec
Gear ratio [i]:	2:1
Torque max [Nm]:	63
Rotation max [1/min]:	3000
Rotating direction:	opposite
Coolant:	EXT
Please note:	Combi bearing
Center distance [mm]:	65

**8 030 66 127 Radial drilling and milling head ER 32 AX UT IC**



Notation:	180° reversible
Tool drive:	Flat (~DIN 1809)
Shank size [mm]:	65.00
Shank type:	BMT
Tool adaption:	ER 32 A - u-tec
Gear ratio [i]:	2:1
Torque max [Nm]:	63
Rotation max [1/min]:	3000
Rotating direction:	opposite
Coolant:	IC/Ext
Pressure max [bar]:	140
Please note:	Combi bearing
Center distance [mm]:	65

**8 030 66 257 Radial drilling and milling head ER 32 AX UT IC**

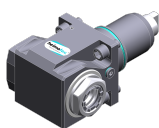

Weight [kg]:	7.800
Notation:	180° reversible
Tool drive:	Flat (~DIN 1809)
Shank size [mm]:	65.00
Shank type:	BMT
Tool adaption:	ER 32 A - u-tec
Gear ratio [i]:	1:1
Torque max [Nm]:	50
Rotation max [1/min]:	12000
Rotating direction:	opposite
Coolant:	IC/Ext
Pressure max [bar]:	140
Center distance [mm]:	65

Part-#	Name
--------	------

**8 030 66 259**



**Radial drilling and milling head ER 32 AX UT IC**  
 Weight [kg]: 11.100  
 Notation: 180° reversible  
 Tool drive: Flat (~DIN 1809)  
 Shank size [mm]: 65.00  
 Shank type: BMT  
 Tool adaption: ER 32 A - u-tec  
 Gear ratio [i]: 1:1  
 Torque max [Nm]: 50  
 Rotation max [1/min]: 6000  
 Rotating direction: opposite  
 Coolant: IC/Ext  
 Pressure max [bar]: 140  
 Please note: Combi bearing  
 Center distance [mm]: 100

**8 030 66 263**

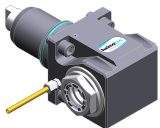

**Radial drilling and milling head ER 32 AX UT**  
 Weight [kg]: 7.600  
 Notation: 180° reversible  
 Tool drive: Flat (~DIN 1809)  
 Shank size [mm]: 65.00  
 Shank type: BMT  
 Tool adaption: ER 32 A - u-tec  
 Gear ratio [i]: 1:1  
 Torque max [Nm]: 50  
 Rotation max [1/min]: 12000  
 Rotating direction: opposite  
 Coolant: EXT  
 Center distance [mm]: 65

**8 030 67 003**

**Radial drilling and milling head Weldon 25 IC**  
 Weight [kg]: 8.720  
 Notation: 180° reversible  
 Version: Special  
 Tool drive: Flat (~DIN 1809)  
 Shank size [mm]: 65.00  
 Shank type: BMT  
 Tool adaption: Weldon (DIN 1835 b) 25 special  
 Gear ratio [i]: 1:1  
 Torque max [Nm]: 50  
 Rotation max [1/min]: 6000  
 Rotating direction: opposite  
 Coolant: IC/Ext  
 Pressure max [bar]: 25  
 Please note: stronger bearing  
 Center distance [mm]: 65

**8 030 67 007**

**Radial drilling and milling head ER 40**  
 Weight [kg]: 7.300  
 Notation: 180° reversible  
 Tool drive: Flat (~DIN 1809)  
 Shank size [mm]: 65.00  
 Shank type: BMT  
 Tool adaption: ER 40  
 Gear ratio [i]: 1,625:1  
 Torque max [Nm]: 63  
 Rotation max [1/min]: 4000

Part-#	Name	
	Rotating direction:	opposite
	Coolant:	EXT
	Center distance [mm]:	65
<b>8 030 67 008</b>	<b>Radial drilling and milling head ER 40</b>	
	Weight [kg]:	7.260
	Notation:	180° reversible
	Tool drive:	Flat (~DIN 1809)
	Shank size [mm]:	65.00
	Shank type:	BMT
	Tool adaption:	ER 40
	Gear ratio [i]:	1:1
	Torque max [Nm]:	50
	Rotation max [1/min]:	6000
	Rotating direction:	opposite
	Coolant:	EXT
	Center distance [mm]:	65
<b>8 030 67 027</b>	<b>Radial drilling and milling head Weldon 25 IC</b>	
	Notation:	180° reversible
	Tool drive:	Flat (~DIN 1809)
	Shank size [mm]:	65.00
	Shank type:	BMT
	Tool adaption:	Weldon (DIN 1835 b) 25
	Gear ratio [i]:	1:1
	Torque max [Nm]:	50
	Rotation max [1/min]:	6000
	Rotating direction:	opposite
	Coolant:	IC/Ext
	Pressure max [bar]:	140
	Please note:	stronger bearing
	Center distance [mm]:	65
<b>8 030 67 028</b>	<b>Radial drilling and milling head HT 5 IC</b>	
	Weight [kg]:	9.200
	Notation:	180° reversible
	Version:	Special
	Tool drive:	Flat (~DIN 1809)
	Shank size [mm]:	65.00
	Shank type:	BMT
	Tool adaption:	HT 5
	Gear ratio [i]:	1:1
	Torque max [Nm]:	50
	Rotation max [1/min]:	6000
	Rotating direction:	opposite
	Coolant:	IC/Ext
	Pressure max [bar]:	25
	Center distance [mm]:	91
<b>8 030 67 037</b>	<b>Radial drilling and milling head Weldon 25 IC</b>	
	Notation:	180° reversible
	Tool drive:	Flat (~DIN 1809)
	Shank size [mm]:	65.00
	Shank type:	BMT
	Tool adaption:	Weldon (DIN 1835 b) 25
	Gear ratio [i]:	2:1
	Torque max [Nm]:	63
	Rotation max [1/min]:	3000

Part-#	Name
--------	------

Rotating direction: opposite  
Coolant: IC/Ext  
Pressure max [bar]: 25  
Please note: stronger bearing  
Center distance [mm]: 65

**8 030 67 088**

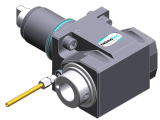

**Radial drilling and milling head HT 5 IC**  
Weight [kg]: 8.420  
Notation: 180° reversible  
Tool drive: Flat (~DIN 1809)  
Shank size [mm]: 65.00  
Shank type: BMT  
Tool adaption: HT 5  
Gear ratio [i]: 1:1  
Torque max [Nm]: 50  
Rotation max [1/min]: 6000  
Rotating direction: opposite  
Coolant: IC/Ext  
Pressure max [bar]: 140  
Please note: Combi bearing  
Center distance [mm]: 65

**8 030 67 120**

**Radial drilling and milling head Weldon 25**  
Notation: 180° reversible  
Tool drive: Flat (~DIN 1809)  
Shank size [mm]: 65.00  
Shank type: BMT  
Tool adaption: Weldon (DIN 1835 b) 25  
Gear ratio [i]: 2:1  
Torque max [Nm]: 63  
Rotation max [1/min]: 3000  
Rotating direction: opposite  
Coolant: EXT  
Please note: Combi bearing  
Center distance [mm]: 65

**8 030 67 140**

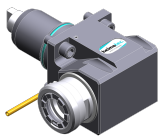

**Radial drilling and milling head ER 40 AX UT**  
Notation: 180° reversible  
Tool drive: Flat (~DIN 1809)  
Shank size [mm]: 65.00  
Shank type: BMT  
Tool adaption: ER 40 A - u-tec  
Gear ratio [i]: 1:1  
Torque max [Nm]: 50  
Rotation max [1/min]: 12000  
Rotating direction: opposite  
Coolant: EXT  
Pressure max [bar]: 140  
Please note: stronger bearing  
Center distance [mm]: 65

## Part-#

## Name

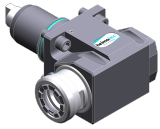
**8 030 67 156****Radial drilling and milling head ER 40 AX UT IC**

Notation:	180° reversible
Tool drive:	Flat (~DIN 1809)
Shank size [mm]:	65.00
Shank type:	BMT
Tool adaption:	ER 40 A - u-tec
Gear ratio [i]:	1:1
Torque max [Nm]:	50
Rotation max [1/min]:	6000
Rotating direction:	opposite
Coolant:	IC/Ext
Pressure max [bar]:	140
Please note:	stronger bearing
Center distance [mm]:	65

**8 037 62 001****Radial disk mill head arbor 10**

Weight [kg]:	12.940
Notation:	180° reversible
Version:	± 10° turnable
Tool drive:	Flat (~DIN 1809)
Shank size [mm]:	65.00
Shank type:	BMT
Tool adaption:	Arbor 10
Gear ratio [i]:	2:1
Torque max [Nm]:	63
Rotation max [1/min]:	3000
Rotating direction:	same
Coolant:	no
Please note:	strong version with stronger bearing
Center distance [mm]:	87,5

**8 037 63 005****Radial disk mill head arbor 13**

Weight [kg]:	12.880
Notation:	180° reversible
Version:	± 10° turnable
Tool drive:	Flat (~DIN 1809)
Shank size [mm]:	65.00
Shank type:	BMT
Tool adaption:	Arbor 13
Gear ratio [i]:	2:1
Torque max [Nm]:	63
Rotation max [1/min]:	3000
Rotating direction:	same
Coolant:	no
Please note:	strong version with stronger bearing
Center distance [mm]:	87,5

**8 037 64 004****Radial disk mill head arbor 16**

Weight [kg]:	12.840
Notation:	180° reversible
Version:	± 10° turnable
Tool drive:	Flat (~DIN 1809)
Shank size [mm]:	65.00
Shank type:	BMT
Tool adaption:	Arbor 16
Gear ratio [i]:	2:1
Torque max [Nm]:	63
Rotation max [1/min]:	3000

Part-#	Name	
	Rotating direction:	same
	Coolant:	no
	Please note:	strong version; stronger bearing
	Center distance [mm]:	87,5
<b>8 037 64 007</b>	<b>Radial disk mill head arbor 3/4"</b>	
	Weight [kg]:	13.300
	Version:	Special
	Tool drive:	Flat (~DIN 1809)
	Shank size [mm]:	65.00
	Shank type:	BMT
	Tool adaption:	Arbor 3/4" (19,05mm)
	Gear ratio [i]:	2:1
	Torque max [Nm]:	63
	Rotation max [1/min]:	3000
	Rotating direction:	same
	Coolant:	no
	Please note:	stronger bearing
	Center distance [mm]:	87,5
<b>8 037 65 000</b>	<b>Woodruff keycutter ER 25 AS</b>	
	Weight [kg]:	7.800
	Tool drive:	Flat (~DIN 1809)
	Shank size [mm]:	65.00
	Shank type:	BMT
	Tool adaption:	ER 25 A
	Gear ratio [i]:	1,333:1
	Torque max [Nm]:	32
	Rotation max [1/min]:	2250
	Rotating direction:	opposite
	Coolant:	EXT
<b>8 037 65 002</b>	<b>Radial disk mill head arbor 22</b>	
	Weight [kg]:	13.420
	Notation:	180° reversible
	Version:	± 10° turnable
	Tool drive:	Flat (~DIN 1809)
	Shank size [mm]:	65.00
	Shank type:	BMT
	Tool adaption:	Arbor 22
	Gear ratio [i]:	2:1
	Torque max [Nm]:	63
	Rotation max [1/min]:	3000
	Rotating direction:	same
	Coolant:	no
	Please note:	strong version with stronger bearing
	Center distance [mm]:	87,5
<b>8 037 65 005</b>	<b>Radial disk mill head arbor 22</b>	
	Weight [kg]:	16.620
	Version:	Special
	Tool drive:	Flat (~DIN 1809)
	Shank size [mm]:	65.00
	Shank type:	BMT
	Tool adaption:	Arbor 22
	Gear ratio [i]:	2:1
	Torque max [Nm]:	63
	Rotation max [1/min]:	3000

Part-#	Name	
	Rotating direction:	same
	Coolant:	EXT
	Please note:	stronger bearing
<b>8 037 65 030</b>	<b>Radial disk mill head arbor 22</b>	
	Weight [kg]:	14.790
	Version:	± 30° turnable
	Tool drive:	Flat (~DIN 1809)
	Shank size [mm]:	65.00
	Shank type:	BMT
	Tool adaption:	Arbor 22
	Gear ratio [i]:	2:1
	Torque max [Nm]:	63
	Rotation max [1/min]:	3000
	Rotating direction:	same
	Coolant:	no
	Please note:	strong version; stronger bearing
	Center distance [mm]:	98
<b>8 037 66 000</b>	<b>Radial disk mill head arbor 27</b>	
	Weight [kg]:	13.260
	Tool drive:	Flat (~DIN 1809)
	Shank size [mm]:	65.00
	Shank type:	BMT
	Tool adaption:	Arbor 27
	Gear ratio [i]:	2:1
	Torque max [Nm]:	63
	Rotation max [1/min]:	3000
	Rotating direction:	same
	Coolant:	no
	Please note:	strong version; stronger bearing
	Center distance [mm]:	87,5
<b>8 039 64 001</b>	<b>Radial drilling and milling head ER 16</b>	
	Weight [kg]:	7.800
	Notation:	60° angle
	Tool drive:	Flat (~DIN 1809)
	Shank size [mm]:	65.00
	Shank type:	BMT
	Tool adaption:	ER 16
	Gear ratio [i]:	1:1
	Torque max [Nm]:	16
	Rotation max [1/min]:	6000
	Rotating direction:	opposite
	Coolant:	EXT
<b>8 039 64 002</b>	<b>Radial drilling and milling head ER 16</b>	
	Weight [kg]:	7.620
	Notation:	30° angle
	Tool drive:	Flat (~DIN 1809)
	Shank size [mm]:	65.00
	Shank type:	BMT
	Tool adaption:	ER 16
	Gear ratio [i]:	1:1
	Torque max [Nm]:	16
	Rotation max [1/min]:	6000
	Rotating direction:	opposite
	Coolant:	EXT

Part-#	Name
--------	------

**8 039 64 003 Radial drilling and milling head ER 16**

Weight [kg]: 7.520  
 Notation: 45° angle  
 Tool drive: Flat (~DIN 1809)  
 Shank size [mm]: 65.00  
 Shank type: BMT  
 Tool adaption: ER 16  
 Gear ratio [i]: 1:1  
 Torque max [Nm]: 16  
 Rotation max [1/min]: 6000  
 Rotating direction: opposite  
 Coolant: EXT

**8 039 65 014 Radial drilling and milling head ER 25 AX UT**

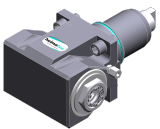

Weight [kg]: 8.760  
 Notation: 180° reversible  
 Employment for: Main- and sub spindle  
 Version: double spindle  
 Tool drive: Flat (~DIN 1809)  
 Shank size [mm]: 65.00  
 Shank type: BMT  
 Tool adaption: ER 25 A - u-tec  
 Gear ratio [i]: 1:1  
 Torque max [Nm]: 50  
 Rotation max [1/min]: 12000  
 Rotating direction: same/opposite  
 Coolant: EXT  
 Please note: stronger bearing  
 Center distance [mm]: 65

**8 039 66 004 Radial milling head universal arbor 27**

Weight [kg]: 9.480  
 Notation: 100° angle  
 Tool drive: Flat (~DIN 1809)  
 Shank size [mm]: 65.00  
 Shank type: BMT  
 Tool adaption: Universal arbor 27  
 Gear ratio [i]: 1,438:1  
 Torque max [Nm]: 40  
 Rotation max [1/min]: 4000  
 Rotating direction: opposite  
 Coolant: EXT  
 Please note: stronger bearing

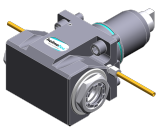

**8 039 66 028 Radial drilling and milling head ER 32 AX UT**



Weight [kg]: 8.600  
 Notation: 180° reversible  
 Employment for: Main- and sub spindle  
 Version: double spindle  
 Tool drive: Flat (~DIN 1809)  
 Shank size [mm]: 65.00  
 Shank type: BMT  
 Tool adaption: ER 32 A - u-tec  
 Gear ratio [i]: 1:1  
 Torque max [Nm]: 50  
 Rotation max [1/min]: 12000  
 Rotating direction: same/opposite

Part-#	Name	
	Coolant:	EXT
	Please note:	stronger bearing
	Center distance [mm]:	65
<b>8 040 64 000</b>	<b>Universal head ± 90° adjustable ER 16</b>	
	Weight [kg]:	4.800
	Tool drive:	Flat (~DIN 1809)
	Shank size [mm]:	65.00
	Shank type:	BMT
	Tool adaption:	ER 16
	Gear ratio [i]:	1:1
	Torque max [Nm]:	10
	Rotation max [1/min]:	5000
	Rotating direction:	same
	Coolant:	EXT
	Center distance [mm]:	64
<b>8 043 64 003</b>	<b>Universal head +100°/-20° adj. ER16 AX UT</b>	
	Weight [kg]:	8.910
	Notation:	offset; 180° reversible
	Tool drive:	Flat (~DIN 1809)
	Shank size [mm]:	65.00
	Shank type:	BMT
	Tool adaption:	ER 16 A - u-tec
	Gear ratio [i]:	1:1
	Torque max [Nm]:	25
	Rotation max [1/min]:	6000
	Rotating direction:	opposite
	Coolant:	EXT
	Center distance [mm]:	60
	Offset [mm]:	35
<b>8 043 64 007</b>	<b>Universal head +145°/-25° adj. ER16AX UTIK</b>	
	Weight [kg]:	8.680
	Notation:	offset; 180° reversible
	Tool drive:	Flat (~DIN 1809)
	Shank size [mm]:	65.00
	Shank type:	BMT
	Tool adaption:	ER 16 A - u-tec
	Gear ratio [i]:	1:1
	Torque max [Nm]:	25
	Rotation max [1/min]:	6000
	Rotating direction:	same
	Coolant:	IC/Ext
	Pressure max [bar]:	140
	Center distance [mm]:	60
	Offset [mm]:	60
<b>8 043 64 012</b>	<b>Universal head +100°/-20° adj. ER16AX UTIK</b>	
	Weight [kg]:	8.960
	Notation:	offset; 180° reversible
	Tool drive:	Flat (~DIN 1809)
	Shank size [mm]:	65.00
	Shank type:	BMT
	Tool adaption:	ER 16 A - u-tec
	Gear ratio [i]:	1:2
	Torque max [Nm]:	12

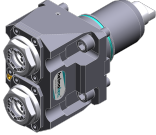
Part-#	Name	
	Rotation max [1/min]:	12000
	Rotating direction:	opposite
	Coolant:	IC/Ext
	Pressure max [bar]:	25
	Center distance [mm]:	60
	Offset [mm]:	35
<b>8 043 64 026</b>	<b>Universal head +100°/-20° adj. ER16AX UTIK</b>	
	Weight [kg]:	8.920
	Notation:	offset; 180° reversible
	Tool drive:	Flat (~DIN 1809)
	Shank size [mm]:	65.00
	Shank type:	BMT
	Tool adaption:	ER 16 A - u-tec
	Gear ratio [i]:	1:1
	Torque max [Nm]:	25
	Rotation max [1/min]:	6000
	Rotating direction:	opposite
	Coolant:	IC/Ext
	Pressure max [bar]:	25
	Center distance [mm]:	60
	Offset [mm]:	35
<b>8 043 65 002</b>	<b>Universal head +100°/-20° adj. ER25 AX UT</b>	
	Weight [kg]:	8.870
	Notation:	offset; 180° reversible
	Tool drive:	Flat (~DIN 1809)
	Shank size [mm]:	65.00
	Shank type:	BMT
	Tool adaption:	ER 25 A - u-tec
	Gear ratio [i]:	1:1
	Torque max [Nm]:	25
	Rotation max [1/min]:	6000
	Rotating direction:	opposite
	Coolant:	EXT
	Please note:	stronger bearing
	Center distance [mm]:	60
	Offset [mm]:	35
<b>8 043 65 011</b>	<b>Universal head +100°/-20° adj. ER25AX UTIK</b>	
	Weight [kg]:	9.170
	Notation:	offset; 180° reversible
	Tool drive:	Flat (~DIN 1809)
	Shank size [mm]:	65.00
	Shank type:	BMT
	Tool adaption:	ER 25 A - u-tec
	Gear ratio [i]:	1:1
	Torque max [Nm]:	25
	Rotation max [1/min]:	6000
	Rotating direction:	opposite
	Coolant:	IC/Ext
	Pressure max [bar]:	25
	Please note:	stronger bearing
	Center distance [mm]:	60
	Offset [mm]:	35

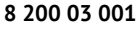
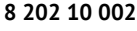
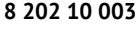
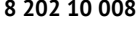
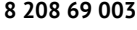
Part-#	Name	
	<b>8 050 65 007 Multispindle drilling head ER 25 AX UT</b>	
	Weight [kg]:	6.740
	Notation:	180° reversible
	Version:	2-spindles
	Tool drive:	Flat (~DIN 1809)
	Shank size [mm]:	65.00
	Shank type:	BMT
	Tool adaption:	ER 25 A - u-tec
	Gear ratio [i]:	1:1
	Torque max [Nm]:	32/Sp.
	Rotation max [1/min]:	6000
	Rotating direction:	opposite
	Coolant:	EXT
	Please note:	stronger bearing
	<b>8 068 64 000 Radial whirling unit HW 46</b>	
	Notation:	180° reversible
	Tool drive:	Flat (~DIN 1809)
	Shank size [mm]:	65.00
	Shank type:	BMT
	Tool adaption:	HW 46
	Gear ratio [i]:	1:1
	Torque max [Nm]:	16
	Rotation max [1/min]:	8000
	Rotating direction:	same
	Coolant:	EXT
	Please note:	without cutting inserts carrier; check applicability;
	Center distance [mm]:	80
	<b>8 200 03 001 Cover plate</b>	
	Weight [kg]:	0.438
	Shank type:	BMT
	<b>8 202 10 002 Basic holder for height adjustable adapter</b>	
	Shank type:	BMT
	Machine adaption:	Centering key b 20
	<b>8 202 10 003 Basic holder for height adjustable adapter</b>	
	Weight [kg]:	2.840
	Shank type:	BMT
	Machine adaption:	Centering key b 20
	Coolant:	EXT
	<b>8 202 10 008 Basic holder longitudinal seat FN 12</b>	
	Weight [kg]:	1.200
	Notation:	180° reversible
	Shank type:	BMT
	Machine adaption:	Centering key b 20
	Tool adaption:	Interface FN 12
	Coolant:	EXT
	<b>8 208 69 003 Test mandrel BMT 65</b>	
	Weight [kg]:	3.280
	Shank size [mm]:	65.00
	Shank type:	BMT

Part-#	Name	
<b>8 209 14 000</b>	<b>Adapter for VDI 40</b>	
	Weight [kg]:	4.560
	Shank type:	BMT
	Machine adaption:	Centering key b 20
	Tool adaption:	DIN 69880 - 40
	Coolant:	EXT
	Center distance [mm]:	35
<b>8 209 14 001</b>	<b>Adapter for VDI 40</b>	
	Weight [kg]:	5.310
	Notation:	180° reversible; offset
	Shank type:	BMT
	Machine adaption:	Centering key b 20
	Tool adaption:	DIN 69880 - 40
	Coolant:	EXT
	Center distance [mm]:	80
<b>8 224 12 010</b>	<b>Cut-off holder sq. 25</b>	
	Weight [kg]:	2.040
	Employment for:	right cutting tools
	Version:	Edge on side of turret
	Shank type:	BMT
	Machine adaption:	Centering key slot b 20
	Tool adaption:	Sq. 25
	Coolant:	EXT
<b>8 224 12 011</b>	<b>Cut-off holder sq. 25</b>	
	Weight [kg]:	2.040
	Employment for:	left cutting tools
	Version:	Edge on center of turret
	Shank type:	BMT
	Machine adaption:	Centering key b 20
	Tool adaption:	Sq. 25
	Coolant:	EXT
<b>8 224 13 008</b>	<b>Cut-off holder SH 32</b>	
	Weight [kg]:	1.840
	Employment for:	Cut-off tool 32
	Version:	Clampshaft on turret side
	Shank type:	BMT
	Machine adaption:	Centering key b 20
	Tool adaption:	Clampshaft SH 32
	Coolant:	EXT
<b>8 224 13 009</b>	<b>Cut-off holder SH 32</b>	
	Weight [kg]:	1.170
	Employment for:	Cut-off tool 32
	Version:	Clampshaft on turret center
	Shank type:	BMT
	Machine adaption:	Centering key b 20
	Tool adaption:	Clampshaft SH 32
	Coolant:	EXT

Part-#	Name	
<b>8 224 15 000</b>	<b>Universal turning holder sq. 25</b>	
	Weight [kg]:	4.380
	Notation:	180° reversible
	Shank type:	BMT
	Machine adaption:	Centering key b 20
	Tool adaption:	Sq. 25
		Sq. 25
	Coolant:	EXT
<b>8 224 15 008</b>	<b>Universal turning holder sq. 1"</b>	
	Weight [kg]:	4.370
	Notation:	180° reversible
	Shank type:	BMT
	Machine adaption:	Centering key b 20
	Tool adaption:	Sq. 1" (25,4mm)
		Sq. 1" (25,4mm)
	Coolant:	EXT
<b>8 224 15 038</b>	<b>Universal turning holder sq. 25 IC</b>	
	Weight [kg]:	4.380
	Shank type:	BMT
	Machine adaption:	Centering key b 20
	Tool adaption:	Sq. 25
		Sq. 25
	Coolant:	IC/Ext
<b>8 224 15 051</b>	<b>Universal turning holder sq. 25 IC</b>	
	Weight [kg]:	4.380
	Notation:	180° reversible
	Shank type:	BMT
	Machine adaption:	Centering key b 20
	Tool adaption:	Sq. 25
		Sq. 25
	Coolant:	IC/Ext
	Pressure max [bar]:	100
	Please note:	Key rail
<b>8 225 12 002</b>	<b>Cut-off holder sq. 25</b>	
	Weight [kg]:	1.640
	Employment for:	left cutting tools
	Version:	Edge on side of turret
	Shank type:	BMT
	Machine adaption:	Centering key b 20
	Tool adaption:	Sq. 25
	Coolant:	EXT
<b>8 225 12 003</b>	<b>Cut-off holder sq. 25</b>	
	Employment for:	right cutting tools
	Version:	Edge on center of turret
	Shank type:	BMT
	Machine adaption:	Centering key b 20
	Tool adaption:	Sq. 25
	Coolant:	EXT

Part-#	Name	
<b>8 229 16 007</b>	<b>Tool holder C 4 IC</b>	
	Notation:	180° reversible
	Version:	right
	Shank type:	BMT
	Machine adaption:	Centering key b 20
	Tool adaption:	heimatec Capto(TM) C 4
	Coolant:	IC
	Please note:	Check applicability; note tool length!
	Offset [mm]:	75
<b>8 229 17 000</b>	<b>Tool holder C 5 IC</b>	
	Weight [kg]:	5.900
	Notation:	180° reversible
	Version:	right
	Shank type:	BMT
	Machine adaption:	Centering key b 20
	Tool adaption:	heimatec Capto(TM) C 5
	Coolant:	IC/Ext
	Please note:	Check applicability; note tool length!
	Offset [mm]:	85
<b>8 240 15 009</b>	<b>Insert drill holder 16 IC</b>	
	Notation:	180° reversible
	Shank type:	BMT
	Tool adaption:	Whistle-Notch (DIN 1835 E) 16
	Coolant:	IC
	Center distance [mm]:	85
<b>8 240 16 003</b>	<b>Boring bar holder Ø 20</b>	
	Weight [kg]:	5.700
	Notation:	180° reversible
	Shank type:	BMT
	Machine adaption:	Centering key b 20
	Tool adaption:	Ø 20
	Coolant:	IC/Ext
	Center distance [mm]:	90
<b>8 240 16 011</b>	<b>Insert drill holder 20 IC</b>	
	Weight [kg]:	7.660
	Notation:	180° reversible
	Shank type:	BMT
	Tool adaption:	Ø 20
	Coolant:	IC
	Center distance [mm]:	85
<b>8 240 16 015</b>	<b>Tool holder hydro 20 - blank</b>	
	Weight [kg]:	4.280
	Notation:	180° reversible
	Version:	Special
	Shank type:	BMT
	Machine adaption:	Centering key b 20
	Tool adaption:	Blank for hydro clamp
	Coolant:	IC/Ext
	Center distance [mm]:	90

Part-#	Name	
<b>8 240 16 031</b>	<b>Collet chuck holder ER 32</b>	
	Notation:	180° reversible
	Shank type:	BMT
	Machine adaption:	Centering key b 20
	Tool adaption:	ER 32
	Coolant:	IC/Ext
	Center distance [mm]:	90
<b>8 240 17 000</b>	<b>Boring bar holder Ø 25</b>	
	Weight [kg]:	5.440
	Shank type:	BMT
	Machine adaption:	Centering key b 20
	Tool adaption:	Ø 25
	Coolant:	IC/Ext
	Center distance [mm]:	90
<b>8 240 17 010</b>	<b>Boring bar holder Ø 30</b>	
	Weight [kg]:	5.960
	Shank type:	BMT
	Machine adaption:	Centering key b 20
	Tool adaption:	Ø 30
	Coolant:	EXT
	Center distance [mm]:	57,5
<b>8 240 17 018</b>	<b>Tool holder HT 5</b>	
	Weight [kg]:	6.480
	Shank type:	BMT
	Machine adaption:	Centering key b 20
	Tool adaption:	HT 5
	Coolant:	IC/Ext
	Center distance [mm]:	90
<b>8 240 17 019</b>	<b>Tool holder HT 5</b>	
	Weight [kg]:	6.080
	Notation:	offset
	Shank type:	BMT
	Machine adaption:	Centering key b 20
	Tool adaption:	HT 5
	Coolant:	IC/Ext
	Center distance [mm]:	90
<b>8 240 17 025</b>	<b>Insert drill holder 25 IC</b>	
	Weight [kg]:	7.630
	Notation:	180° reversible
	Shank type:	BMT
	Tool adaption:	Whistle-Notch (DIN 1835 E) 25
	Coolant:	IC
	Center distance [mm]:	85
<b>8 240 17 060</b>	<b>Collet chuck holder ER 40</b>	
	Notation:	180° reversible
	Shank type:	BMT
	Machine adaption:	Centering key b 20
	Tool adaption:	ER 40
	Coolant:	IC/Ext
	Center distance [mm]:	90





Part-#	Name	
<b>8 240 17 082</b>	<b>Tool holder C 5 IC</b>	
	Weight [kg]:	6.020
	Notation:	180° reversible
	Version:	offset; right
	Shank type:	BMT
	Machine adaption:	Centering key b 20
	Tool adaption:	heimatec Capto(TM) C 5
	Coolant:	IC
	Center distance [mm]:	80
<b>8 240 17 113</b>	<b>Tool holder C 5 IC</b>	
	Weight [kg]:	7.200
	Notation:	180° reversible
	Version:	right
	Shank type:	BMT
	Machine adaption:	Centering key b 20
	Tool adaption:	heimatec Capto(TM) C 5
	Coolant:	IC
	Center distance [mm]:	80
<b>8 240 18 000</b>	<b>Boring bar holder Ø 32</b>	
	Weight [kg]:	5.220
	Notation:	180° reversible
	Shank type:	BMT
	Machine adaption:	Centering key b 20
	Tool adaption:	Ø 32
	Coolant:	IC/Ext
	Center distance [mm]:	90
<b>8 240 18 002</b>	<b>Boring bar holder Ø 32</b>	
	Weight [kg]:	5.760
	Notation:	offset
	Shank type:	BMT
	Machine adaption:	Centering key b 20
	Tool adaption:	Ø 32
	Coolant:	IC/Ext
	Center distance [mm]:	90
<b>8 240 18 020</b>	<b>Boring bar holder Ø 32</b>	
	Weight [kg]:	3.800
	Version:	Special
	Shank type:	BMT
	Machine adaption:	Centering key b 20
	Tool adaption:	Ø 32
	Coolant:	IC/Ext
	Center distance [mm]:	60
<b>8 240 18 022</b>	<b>Insert drill holder 32 IC</b>	
	Weight [kg]:	7.400
	Notation:	180° reversible
	Shank type:	BMT
	Tool adaption:	Ø 32
	Coolant:	IC
	Center distance [mm]:	85

Part-#	Name	
<b>8 240 18 035</b>	<b>Boring bar holder Ø 1 1/2"</b>	
	Weight [kg]:	4.910
	Notation:	180° reversible
	Shank type:	BMT
	Machine adaption:	Centering key b 20
	Tool adaption:	Ø 1 1/2" (38,1mm)
	Coolant:	IC/Ext
	Center distance [mm]:	90
<b>8 240 18 041</b>	<b>Boring bar holder Ø 1 1/4"</b>	
	Weight [kg]:	5.160
	Notation:	180° reversible
	Shank type:	BMT
	Machine adaption:	Centering key b 20
	Tool adaption:	Ø 1 1/4" (31,75mm)
	Coolant:	IC/Ext
	Center distance [mm]:	90
<b>8 240 19 000</b>	<b>Boring bar holder Ø 40</b>	
	Weight [kg]:	4.830
	Notation:	180° reversible
	Shank type:	BMT
	Machine adaption:	Centering key b 20
	Tool adaption:	Ø 40
	Coolant:	IC/Ext
	Center distance [mm]:	90
<b>8 240 19 004</b>	<b>Boring bar holder Ø 50</b>	
	Weight [kg]:	7.600
	Notation:	offset
	Shank type:	BMT
	Machine adaption:	Centering key b 20
	Tool adaption:	Ø 50
	Coolant:	IC/Ext
	Center distance [mm]:	85
<b>8 240 19 005</b>	<b>Boring bar holder Ø 40 offset</b>	
	Weight [kg]:	7.920
	Notation:	180° reversible
	Version:	offset
	Shank type:	BMT
	Machine adaption:	Centering key b 20
	Tool adaption:	Ø 40
	Coolant:	IC/Ext
	Center distance [mm]:	90
	Offset [mm]:	60
<b>8 240 19 006</b>	<b>Boring bar holder Ø 42</b>	
	Notation:	180° reversible
	Version:	Special
	Shank type:	BMT
	Machine adaption:	Centering key b 20
	Tool adaption:	Ø 42
	Coolant:	IC/Ext
	Center distance [mm]:	90

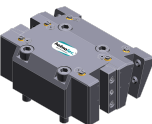
Part-#	Name	
<b>8 240 19 017</b>	<b>Boring bar holder Ø 40</b>	
	Weight [kg]:	3.540
	Version:	Special
	Shank type:	BMT
	Machine adaption:	Centering key b 20
	Tool adaption:	Ø 40
	Coolant:	IC/Ext
	Center distance [mm]:	60
<b>8 240 19 019</b>	<b>Insert drill holder 40 IC</b>	
	Weight [kg]:	7.100
	Notation:	180° reversible
	Shank type:	BMT
	Tool adaption:	Ø 40
	Coolant:	IC
	Center distance [mm]:	85
<b>8 244 12 000</b>	<b>Facing holder sq. 25</b>	
	Weight [kg]:	5.460
	Notation:	180° reversible
	Shank type:	BMT
	Machine adaption:	Centering key b 20
	Tool adaption:	Sq. 25
	Coolant:	EXT
<b>8 249 16 011</b>	<b>Double collet chuck holder ER 32</b>	
	Weight [kg]:	5.940
	Notation:	180° reversible
	Employment for:	Main- and sub spindle
	Shank type:	BMT
	Machine adaption:	Centering key b 20
	Tool adaption:	ER 32
		ER 32
	Coolant:	IC/Ext
	Center distance [mm]:	90
<b>8 249 17 006</b>	<b>Double collet chuck holder ER 40</b>	
	Notation:	180° reversible
	Employment for:	Main- and sub spindle
	Shank type:	BMT
	Machine adaption:	Centering key b 20
	Tool adaption:	ER 40
		ER 40
	Coolant:	IC/Ext
	Center distance [mm]:	90
<b>8 250 16 006</b>	<b>Double tool holder C 4 IC</b>	
	Weight [kg]:	5.500
	Employment for:	Main- and sub spindle
	Version:	right
	Shank type:	BMT
	Machine adaption:	Centering key b 20
	Tool adaption:	heimatec Capto(TM) C 4
		heimatec Capto(TM) C 4
	Coolant:	IC
	Please note:	Check applicability; note tool length!

Part-#	Name	
	Offset [mm]:	±75
<b>8 250 16 010</b>	<b>Double tool holder C 4 IC</b>	
	Weight [kg]:	2.940
	Employment for:	Main- and sub spindle
	Version:	right
	Shank type:	BMT
	Machine adaption:	Centering key b 20
	Tool adaption:	heimatec Capto(TM) C 4 heimatec Capto(TM) C 4
	Coolant:	IC
	Pressure max [bar]:	80
	Please note:	Check applicability; note tool length!
	Offset [mm]:	±24
<b>8 251 12 000</b>	<b>Double turning holder sq. 25</b>	
	Weight [kg]:	6.920
	Employment for:	right cutting tools
	Shank type:	BMT
	Machine adaption:	Centering key b 20
	Tool adaption:	Sq. 25
	Coolant:	EXT
<b>8 251 13 011</b>	<b>Combi multiple holder 6x sq. 3/4" IC</b>	
	Employment for:	Main- and sub spindle
	Shank type:	BMT
	Machine adaption:	Centering key b 20
	Tool adaption:	Sq. 3/4" (19,05mm) Sq. 3/4" (19,05mm) Sq. 3/4" (19,05mm) Sq. 3/4" (19,05mm)
	Coolant:	IC/Ext
	Pressure max [bar]:	100
	Please note:	Key rail
<b>8 251 14 009</b>	<b>Combi multiple holder 6x sq. 20</b>	
	Weight [kg]:	7.820
	Employment for:	Main- and sub spindle
	Shank type:	BMT
	Machine adaption:	Centering key b 20
	Tool adaption:	Sq. 20 Sq. 20 Sq. 20 Sq. 20
	Coolant:	EXT
<b>8 251 14 021</b>	<b>Combi multiple holder 6x sq. 3/4"</b>	
	Weight [kg]:	7.860
	Employment for:	Main- and sub spindle
	Shank type:	BMT
	Machine adaption:	Centering key b 20
	Tool adaption:	Sq. 3/4" (19,05mm) Sq. 3/4" (19,05mm) Sq. 3/4" (19,05mm) Sq. 3/4" (19,05mm)
	Coolant:	EXT



Part-#	Name	
<b>8 251 14 086</b>	<b>Combi multiple holder 6x sq. 20 IC</b>	
	Employment for: Shank type: Machine adaption: Tool adaption:	Main- and sub spindle BMT Centering key b 20 Sq. 20 Sq. 20 Sq. 20 Sq. 20 IC/Ext 100 Key rail
	Coolant: Pressure max [bar]: Please note:	
<b>8 251 15 000</b>	<b>Combi double turning holder sq. 25</b>	
	Weight [kg]: Shank type: Machine adaption: Tool adaption:	6.800 BMT Centering key b 20 Sq. 25 Sq. 25 Sq. 25 Sq. 25 EXT
	Coolant:	
<b>8 251 15 007</b>	<b>Combi double turning holder sq. 1"</b>	
	Weight [kg]: Shank type: Machine adaption: Tool adaption:	6.780 BMT Centering key b 20 Sq. 1" (25,4mm) Sq. 1" (25,4mm) Sq. 1" (25,4mm) Sq. 1" (25,4mm) EXT
	Coolant:	
<b>8 251 16 001</b>	<b>Multiple tool holder C 4 IC</b>	
	Weight [kg]: Employment for: Version: Shank type: Machine adaption: Tool adaption:	7.400 Main- and sub spindle right BMT Centering key b 20 heimatec Capto(TM) C 4 heimatec Capto(TM) C 4
	Coolant: Please note: Offset [mm]:	IC Check applicability; note tool length! ±75 ±75
<b>8 251 16 002</b>	<b>Multiple tool holder C 4 IC</b>	
	Version: Shank type: Machine adaption: Tool adaption:	right BMT Centering key b 20 heimatec Capto(TM) C 4 heimatec Capto(TM) C 4 - 15°
	Coolant: Please note: Offset [mm]:	IC Check applicability; note tool length! 75 75

Part-#	Name	
<b>8 251 16 003</b>	<b>Multiple tool holder C 4 IC</b>	
	Version:	right
	Shank type:	BMT
	Machine adaption:	Centering key b 20
	Tool adaption:	heimatec Capto(TM) C 4 heimatec Capto(TM) C 4 - 15°
	Coolant:	IC
	Please note:	Check applicability; note tool length!
	Offset [mm]:	75 75
<b>8 253 15 016</b>	<b>Double boring bar holder Ø 16</b>	
	Weight [kg]:	5.440
	Notation:	180° reversible
	Shank type:	BMT
	Machine adaption:	Centering key b 20
	Tool adaption:	Ø 16 Ø 16
	Coolant:	IC/Ext
	Please note:	untere boring bar zur main spindle obere boring bar zur
	Center distance [mm]:	57,5/100
<b>8 253 16 000</b>	<b>Double tool holder HT 4</b>	
	Weight [kg]:	6.620
	Shank type:	BMT
	Machine adaption:	Centering key b 20
	Tool adaption:	HT 4
	Coolant:	IC/Ext
	Please note:	Holder 180° reversible
	Center distance [mm]:	57,5/100
<b>8 253 16 035</b>	<b>Double boring bar holder Ø 20</b>	
	Weight [kg]:	5.280
	Notation:	180° reversible
	Shank type:	BMT
	Machine adaption:	Centering key b 20
	Tool adaption:	Ø 20 Ø 20
	Coolant:	IC/Ext
	Please note:	untere boring bar zur main spindle obere boring bar zur
	Center distance [mm]:	57,5/100
<b>8 253 17 007</b>	<b>Double boring bar holder Ø 25</b>	
	Weight [kg]:	4.980
	Notation:	180° reversible
	Shank type:	BMT
	Machine adaption:	Centering key b 20
	Tool adaption:	Ø 25 Ø 25
	Coolant:	IC/Ext
	Center distance [mm]:	57,5/100

Part-#	Name	
<b>8 253 17 019</b>	<b>Multiple boring bar holder 3x Ø 25</b>	
	Weight [kg]:	8.260
	Notation:	180° reversible
	Employment for:	Main- and sub spindle
	Shank type:	BMT
	Machine adaption:	Centering key b 20
	Tool adaption:	Ø 25 Ø 25
	Coolant:	IC/Ext
	Center distance [mm]:	57,5/97,5
<b>8 253 17 041</b>	<b>Double boring bar holder Ø 25</b>	
	Weight [kg]:	5.560
	Notation:	180° reversible
	Version:	Special
	Shank type:	BMT
	Machine adaption:	Centering key b 20
	Tool adaption:	Ø 25 Ø 25
	Coolant:	IC/Ext
	Center distance [mm]:	65/110
<b>8 253 17 045</b>	<b>Multiple boring bar holder 3x Ø 1"</b>	
	Weight [kg]:	8.370
	Notation:	180° reversible
	Employment for:	Main- and sub spindle
	Shank type:	BMT
	Machine adaption:	Centering key b 20
	Tool adaption:	Ø 1" (25,4mm) Ø 1" (25,4mm)
	Coolant:	IC/Ext
	Center distance [mm]:	57,5/97,5
<b>8 253 17 050</b>	<b>Double boring bar holder Ø 1"</b>	
	Weight [kg]:	4.940
	Notation:	180° reversible
	Shank type:	BMT
	Machine adaption:	Centering key b 20
	Tool adaption:	Ø 1" (25,4mm) Ø 1" (25,4mm)
	Coolant:	IC/Ext
	Center distance [mm]:	57,5/100
<b>8 253 17 089</b>	<b>Double boring bar holder Ø 25</b>	
	Weight [kg]:	4.980
	Notation:	180° reversible
	Shank type:	BMT
	Machine adaption:	Centering key b 20
	Tool adaption:	Ø 25 Ø 25
	Coolant:	IC/Ext
	Please note:	untere boring bar zur main spindle obere boring bar zur
	Center distance [mm]:	57,5/100

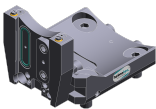
Part-#	Name	
<b>8 253 18 018</b>	<b>Double boring bar holder Ø 32</b>	
	Weight [kg]:	8.420
	Notation:	180° reversible
	Shank type:	BMT
	Machine adaption:	Centering key b 20
	Tool adaption:	Ø 32
		Ø 32
	Coolant:	IC/Ext
	Please note:	untere boring bar zur main spindle obere boring bar zur
	Center distance [mm]:	57,5/100
<b>8 259 16 008</b>	<b>Multiple tool holder C 4 IC</b>	
	Weight [kg]:	11.580
	Employment for:	Main- and sub spindle
	Version:	right
	Shank type:	BMT
	Machine adaption:	Centering key b 20
	Tool adaption:	heimatec Capto(TM) C 4
		heimatec Capto(TM) C 4
	Coolant:	IC
	Pressure max [bar]:	80
	Please note:	Check applicability; note tool length!
	Center distance [mm]:	90
<b>8 259 19 003</b>	<b>Multiple holder Ø 25 and sq. 20</b>	
	Weight [kg]:	9.100
	Notation:	180° reversible
	Employment for:	Main- and sub spindle
	Shank type:	BMT
	Machine adaption:	Centering key b 20
	Tool adaption:	Sq. 20
		Sq. 20
		Sq. 20
		Sq. 20
	Coolant:	IC/Ext
	Center distance [mm]:	97,5
<b>8 261 18 002</b>	<b>Tool holder for centering insert</b>	
	Weight [kg]:	6.110
	Notation:	180° reversible
	Shank type:	BMT
	Machine adaption:	Centering key b 20
	Tool adaption:	Ø 32
	Coolant:	EXT
	Please note:	Price without centering point
	Center distance [mm]:	57,5
<b>8 263 19 010</b>	<b>Tool holder with rotating centering point</b>	
	Weight [kg]:	8.160
	Notation:	180° reversible
	Shank type:	BMT
	Machine adaption:	Centering key b 20
	Rotation max [1/min]:	6000
	Coolant:	EXT
	Please note:	Taper roller bearings
	Center distance [mm]:	90

Part-#	Name	
<b>8 263 19 031</b>	<b>Tool holder with rotating centering point</b>	
	Weight [kg]:	8.280
	Notation:	180° reversible
	Shank type:	BMT
	Machine adaption:	Centering key b 20
	Rotation max [1/min]:	6000
	Coolant:	EXT
	Please note:	Taper roller bearings
	Center distance [mm]:	90
<b>8 269 19 001</b>	<b>Tool holder with rotating centering point</b>	
	Weight [kg]:	8.510
	Notation:	180° reversible
	Version:	Special; double spindle
	Shank type:	BMT
	Machine adaption:	Centering key b 20
	Rotation max [1/min]:	6000
	Coolant:	EXT
	Please note:	Taper roller bearings
	Center distance [mm]:	90
<b>8 269 19 002</b>	<b>Tool holder with rotating centering point</b>	
	Weight [kg]:	8.380
	Notation:	180° reversible
	Version:	Special; double spindle
	Shank type:	BMT
	Machine adaption:	Centering key b 20
	Rotation max [1/min]:	6000
	Coolant:	EXT
	Please note:	Taper roller bearings
	Center distance [mm]:	90
<b>8 320 13 004</b>	<b>Cut-off holder, height adjustable SH 32 IC</b>	
	Weight [kg]:	1.830
	Notation:	180° reversible
	Shank type:	BMT
	Machine adaption:	Centering key b 20
	Tool adaption:	Clampshaft SH 32
	Coolant:	IC/Ext
	Pressure max [bar]:	70
<b>8 320 13 016</b>	<b>Cut-off holder, height adjustable SH 32 IC</b>	
	Weight [kg]:	2.050
	Notation:	180° reversible
	Shank type:	BMT
	Machine adaption:	Centering key b 20
	Tool adaption:	Clampshaft SH 32
	Coolant:	IC/Ext
	Pressure max [bar]:	70
	Please note:	with offset cut-off tool holder use

Part-#	Name	
<b>8 320 13 017</b>	<b>Cut-off holder, height adjustable SH 32 IC</b>	
	Weight [kg]:	1.960
	Notation:	180° reversible
	Shank type:	BMT
	Machine adaption:	Centering key b 20
	Tool adaption:	Clampshaft SH 32
	Coolant:	IC/Ext
	Pressure max [bar]:	70
	Please note:	Clampshaft internal
<b>8 320 19 002</b>	<b>Cut-off holder, height adjustable 845 IC</b>	
	Weight [kg]:	1.740
	Notation:	180° reversible
	Shank type:	BMT
	Machine adaption:	Centering key b 20
	Tool adaption:	 System 845
	Coolant:	IC
	Pressure max [bar]:	70
<b>8 320 19 017</b>	<b>Cut-off holder, height adjustable 845 IC</b>	
	Notation:	180° reversible
	Shank type:	BMT
	Machine adaption:	Centering key b 20
	Tool adaption:	 System 845
	Coolant:	IC
	Pressure max [bar]:	70
	Please note:	Clampshaft internal

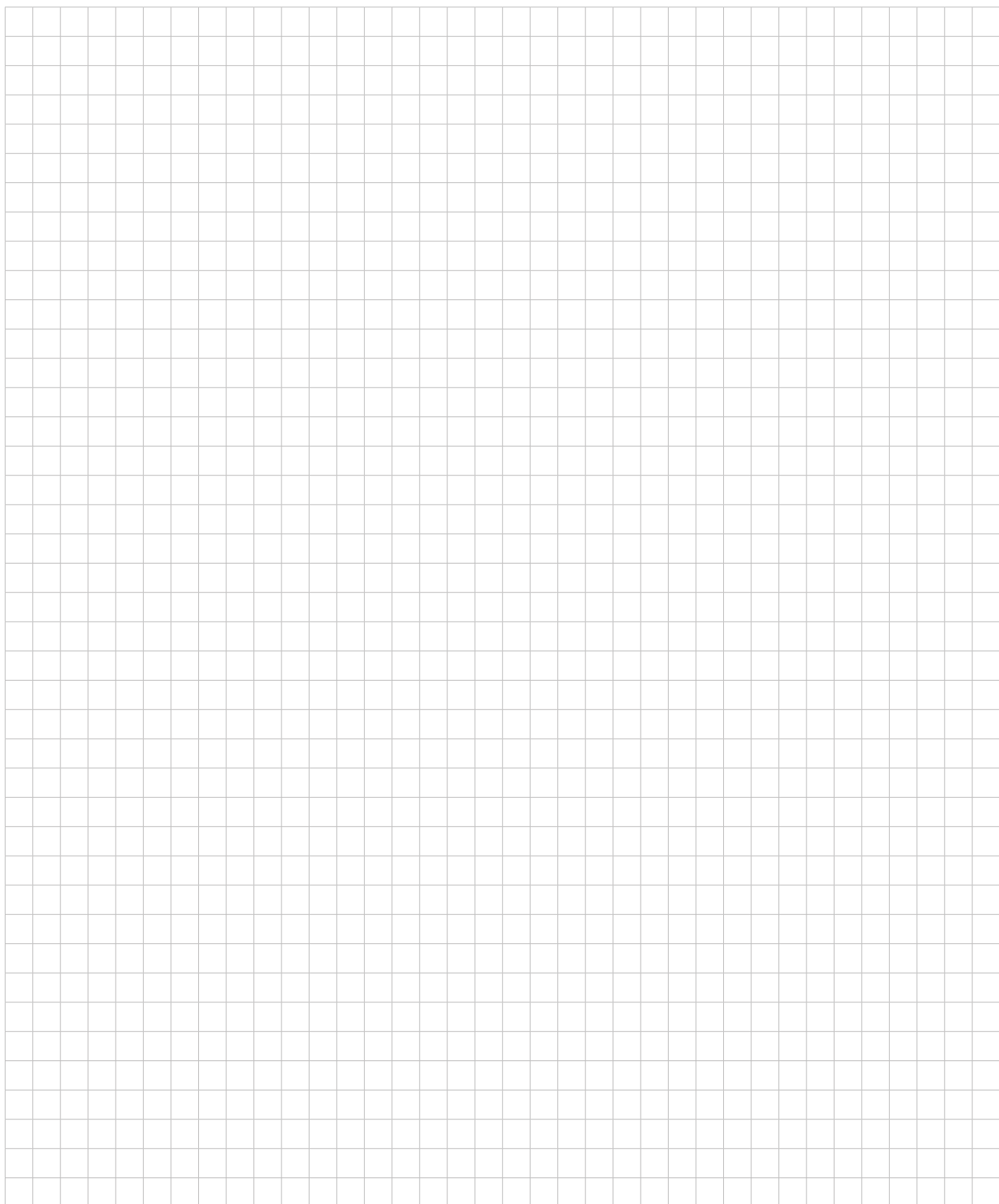

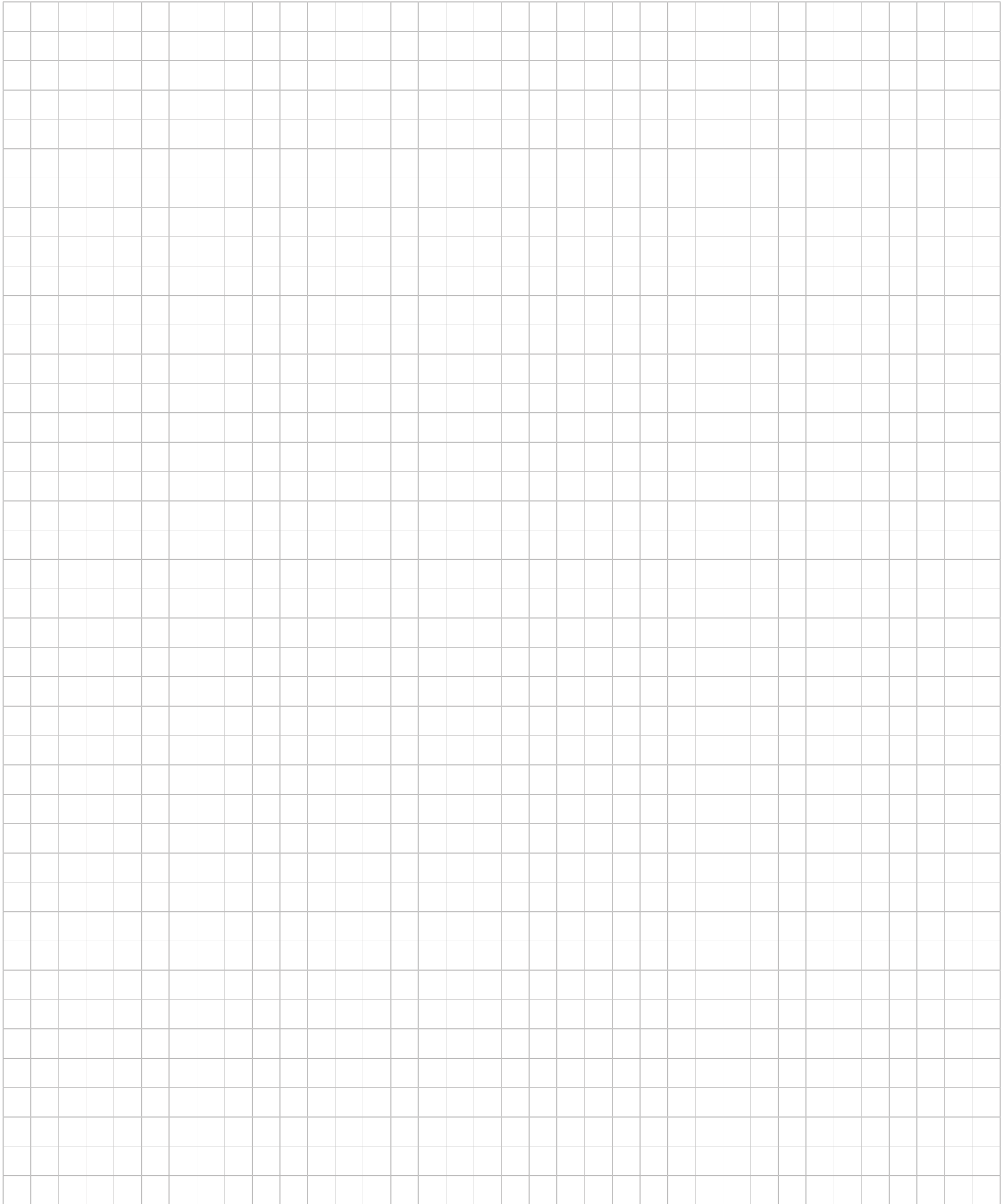

## heimatec.u-tec®

heimatec.com

Products / Tool change systems /  
u-tec® Tool-changing system



versions see catalog

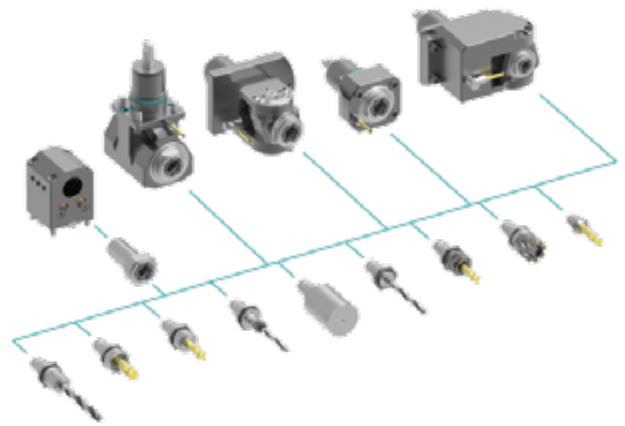

## heimatec.easy-quick

heimatec.com

Products / Tool change systems /  
easy-quick HT quick-changing system



versions see catalog

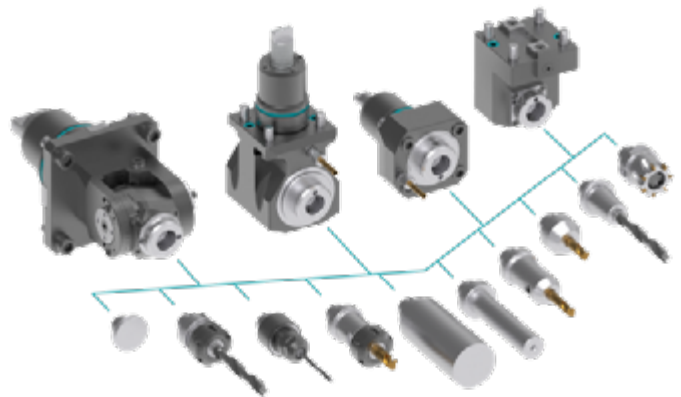

## heimatec.Capto™

heimatec.com

Products / Tool change systems /  
heimatec.Capto™ quick-changing system



versions see catalog

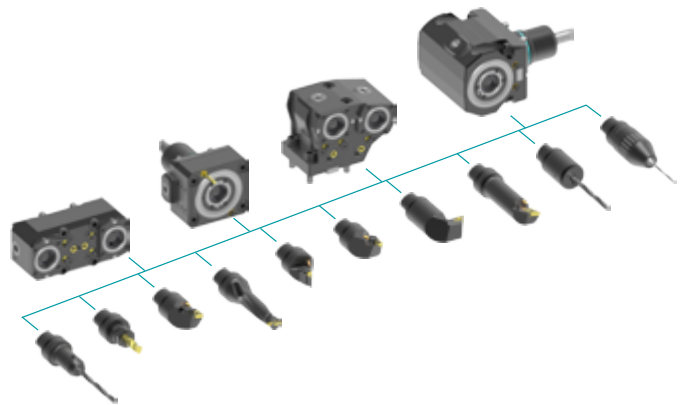

## heimatec.accessories

heimatec.com

Products / Accessories



versions see catalog





● heimatec overseas branches

○ global representations of heimatec

**heimatec**<sup>®</sup>

**heimatec GmbH**  
Präzisionswerkzeuge  
Carl-Benz-Str. 4  
77871 Renchen  
Germany

T +49 7843 9466 0  
[www.heimatec.com](http://www.heimatec.com)  
[info@heimatec.com](mailto:info@heimatec.com)

Please find the contact details of our worldwide trading partners on our website:  
<https://heimatec.com/business-partners>