

Gildemeister
CTV 250



High-tech from heimatec - heimatec - Tools and systems for productive turning and milling

heimatec belongs to the international technology and quality leaders for precision tools and specializes in the development and production of high-precision static and live tools for all CNC lathes, CNC turn-/mill machines and CNC machining centers.

The range of products* spans from static BMT and VDI tool holders, live tools up to highly complex customer-specific individual solutions. heimatec, headquartered in Renchen, has a own subsidiary in Asia and India and numerous representatives as well as trading partners all over the world.

*OUR PRODCUTS

Static tool holders

Live tool units

Precision tools

Tools for turning and machining centres

Tools for swiss type lathes

Tool changing and uick-change systems

Tool systems for gear production

Digital tool management

This catalogue, including all its parts, is protected by copyright. Any use outside the restricted limitations of the Copyright Act without the consent of heimatec is inadmissible and liable to prosecution. This applies in particular to duplication, translation, microfilming and storage and processing in electronic systems.

heimatec GmbH reserves the right to make technical changes at any time without giving prior notice. This applies in particular to adjustments at any time to meet new or changed international standards, or in case of further developments of our products or manufacturing processes.

The current version of our General Terms and Conditions can be found on our website.

Part-#	Name
--------	------

8 010 45 053	Axial drilling and milling head ER 25 IC
Weight [kg]:	3.420
Tool drive:	DIN 5480
Shank size [mm]:	40.00
Shank type:	VDI
Tool adaption:	ER 25
Gear ratio [i]:	1:1
Torque max [Nm]:	50
Rotation max [1/min]:	6000
Rotating direction:	same
Coolant:	IC/Ext
Pressure max [bar]:	25
Please note:	round housing ø 84

8 010 45 094	Axial drilling and milling head ER 25 AX UT
Weight [kg]:	3.440
Tool drive:	DIN 5480
Shank size [mm]:	40.00
Shank type:	VDI
Tool adaption:	ER 25 A - u-tec
Gear ratio [i]:	1:1
Torque max [Nm]:	50
Rotation max [1/min]:	6000
Rotating direction:	same
Coolant:	EXT

8 010 45 156	Axial drilling and milling head ER 25 AX UT IC
Weight [kg]:	3.410
Tool drive:	DIN 5480
Shank size [mm]:	40.00
Shank type:	VDI
Tool adaption:	ER 25 A - u-tec
Gear ratio [i]:	1:1
Torque max [Nm]:	50
Rotation max [1/min]:	6000
Rotating direction:	same
Coolant:	IC/Ext
Pressure max [bar]:	25



8 010 46 152	Axial drilling and milling head ER 32 AX UT
Weight [kg]:	3.270
Tool drive:	DIN 5480
Shank size [mm]:	40.00
Shank type:	VDI
Tool adaption:	ER 32 A - u-tec
Gear ratio [i]:	1:1
Torque max [Nm]:	50
Rotation max [1/min]:	6000
Rotating direction:	same
Coolant:	EXT

Part-#	Name	
8 010 46 165	Axial drilling and milling head ER 32 AX UT IC	
	Weight [kg]:	3.440
	Tool drive:	DIN 5480
	Shank size [mm]:	40.00
	Shank type:	VDI
	Tool adaption:	ER 32 A - u-tec
	Gear ratio [i]:	1:1
	Torque max [Nm]:	50
	Rotation max [1/min]:	6000
	Rotating direction:	same
	Coolant:	IC/Ext
	Pressure max [bar]:	25
8 010 46 235	Axial drilling and milling head ER 32 AX UT IC	
	Tool drive:	DIN 5480
	Shank size [mm]:	40.00
	Shank type:	VDI
	Tool adaption:	ER 32 A - u-tec
	Gear ratio [i]:	1:1
	Torque max [Nm]:	50
	Rotation max [1/min]:	10000
	Rotating direction:	same
	Coolant:	IC/Ext
	Pressure max [bar]:	100
	Please note:	Dryrun possible
8 010 46 304	Axial drilling and milling head C 4	
	Weight [kg]:	4.330
	Version:	right
	Tool drive:	DIN 5480
	Shank size [mm]:	40.00
	Shank type:	VDI
	Tool adaption:	heimatec Capto(TM) C 4
	Gear ratio [i]:	1:1
	Torque max [Nm]:	50
	Rotation max [1/min]:	6000
	Rotating direction:	same
	Coolant:	EXT
	Please note:	stronger bearing
8 010 47 034	Axial drilling and milling head HT 5	
	Weight [kg]:	3.300
	Tool drive:	DIN 5480
	Shank size [mm]:	40.00
	Shank type:	VDI
	Tool adaption:	HT 5
	Gear ratio [i]:	1:1
	Torque max [Nm]:	50
	Rotation max [1/min]:	6000
	Rotating direction:	same
	Coolant:	EXT
	Please note:	round housing Ø 84

Part-#	Name	
8 010 47 086	Axial drilling and milling head HT 5	
	Weight [kg]:	3.330
	Tool drive:	DIN 5480
	Shank size [mm]:	40.00
	Shank type:	VDI
	Tool adaption:	HT 5
	Gear ratio [i]:	1:1
	Torque max [Nm]:	50
	Rotation max [1/min]:	4000
	Rotating direction:	same
	Coolant:	EXT
	Please note:	Combi bearing
8 010 48 001	Axial drilling and milling head HT 6 IC	
	Weight [kg]:	4.220
	Tool drive:	DIN 5480
	Shank size [mm]:	40.00
	Shank type:	VDI
	Tool adaption:	HT 6
	Gear ratio [i]:	1:1
	Torque max [Nm]:	50
	Rotation max [1/min]:	6000
	Rotating direction:	same
	Coolant:	IC/Ext
	Pressure max [bar]:	25
	Please note:	round housing ø 84
8 013 44 005	Axial drilling and milling head ER 16 AX UT	
	Weight [kg]:	2.940
	Tool drive:	DIN 5480
	Shank size [mm]:	40.00
	Shank type:	VDI
	Tool adaption:	ER 16 A - u-tec
	Gear ratio [i]:	1:4
	Torque max [Nm]:	5
	Rotation max [1/min]:	24000
	Rotating direction:	same
	Coolant:	EXT
8 030 45 085	Radial drilling and milling head ER 25	
	Weight [kg]:	6.560
	Version:	right
	Tool drive:	DIN 5480
	Shank size [mm]:	40.00
	Shank type:	VDI
	Tool adaption:	ER 25
	Gear ratio [i]:	1:1
	Torque max [Nm]:	50
	Rotation max [1/min]:	6000
	Rotating direction:	opposite
	Coolant:	EXT
	Center distance [mm]:	100

Part-#	Name	
8 030 45 090	Radial drilling and milling head ER 25	
	Version:	left
	Tool drive:	DIN 5480
	Shank size [mm]:	40.00
	Shank type:	VDI
	Tool adaption:	ER 25
	Gear ratio [i]:	1:1
	Torque max [Nm]:	50
	Rotation max [1/min]:	6000
	Rotating direction:	opposite
	Coolant:	EXT
	Center distance [mm]:	100
8 030 46 113	Radial drilling and milling head ER 32	
	Weight [kg]:	7.500
	Version:	left
	Tool drive:	DIN 5480
	Shank size [mm]:	40.00
	Shank type:	VDI
	Tool adaption:	ER 32
	Gear ratio [i]:	1:1
	Torque max [Nm]:	50
	Rotation max [1/min]:	6000
	Rotating direction:	opposite
	Coolant:	EXT
	Please note:	with fixation pin
	Center distance [mm]:	120
8 030 46 119	Radial drilling and milling head ER 32	
	Weight [kg]:	6.630
	Version:	left
	Tool drive:	DIN 5480
	Shank size [mm]:	40.00
	Shank type:	VDI
	Tool adaption:	ER 32
	Gear ratio [i]:	1:1
	Torque max [Nm]:	50
	Rotation max [1/min]:	6000
	Rotating direction:	opposite
	Coolant:	EXT
	Center distance [mm]:	100
8 030 46 120	Radial drilling and milling head ER 32 IC	
	Weight [kg]:	7.990
	Version:	left
	Tool drive:	DIN 5480
	Shank size [mm]:	40.00
	Shank type:	VDI
	Tool adaption:	ER 32
	Gear ratio [i]:	1:1
	Torque max [Nm]:	50
	Rotation max [1/min]:	6000
	Rotating direction:	opposite
	Coolant:	IC/Ext
	Pressure max [bar]:	140
	Center distance [mm]:	120

Part-#	Name	
8 030 46 141	Radial drilling and milling head ER 32	
	Weight [kg]:	7.480
	Version:	left
	Tool drive:	DIN 5480
	Shank size [mm]:	40.00
	Shank type:	VDI
	Tool adaption:	ER 32
	Gear ratio [i]:	2:1
	Torque max [Nm]:	63
	Rotation max [1/min]:	3000
	Rotating direction:	opposite
	Coolant:	EXT
	Please note:	with fixation pin
	Center distance [mm]:	120
8 030 46 170	Radial drilling and milling head ER 32 IC	
	Version:	left
	Tool drive:	DIN 5480
	Shank size [mm]:	40.00
	Shank type:	VDI
	Tool adaption:	ER 32
	Gear ratio [i]:	1:1
	Torque max [Nm]:	50
	Rotation max [1/min]:	6000
	Rotating direction:	opposite
	Coolant:	IC/Ext
	Pressure max [bar]:	140
	Please note:	with fixation pin
	Center distance [mm]:	100
8 030 46 249	Radial drilling and milling head ER 32	
	Weight [kg]:	6.820
	Version:	left
	Tool drive:	DIN 5480
	Shank size [mm]:	40.00
	Shank type:	VDI
	Tool adaption:	ER 32
	Gear ratio [i]:	1:1
	Torque max [Nm]:	50
	Rotation max [1/min]:	6000
	Rotating direction:	same
	Coolant:	EXT
	Center distance [mm]:	100
8 030 46 251	Radial drilling and milling head ER 32 IC	
	Weight [kg]:	7.540
	Version:	left
	Tool drive:	DIN 5480
	Shank size [mm]:	40.00
	Shank type:	VDI
	Tool adaption:	ER 32
	Gear ratio [i]:	1:1
	Torque max [Nm]:	50
	Rotation max [1/min]:	6000
	Rotating direction:	same
	Coolant:	IC/Ext
	Pressure max [bar]:	25
	Center distance [mm]:	100

Part-#	Name
8 030 46 304	Radial drilling and milling head ER 32 AX UT IC
	Version: left
	Tool drive: DIN 5480
	Shank size [mm]: 40.00
	Shank type: VDI
	Tool adaption: ER 32 A - u-tec
	Gear ratio [i]: 1:1
	Torque max [Nm]: 50
	Rotation max [1/min]: 6000
	Rotating direction: opposite
	Coolant: IC/Ext
	Pressure max [bar]: 140
	Center distance [mm]: 100
8 030 46 306	Radial drilling and milling head ER 32 AX UT
	Weight [kg]: 6.390
	Version: left
	Tool drive: DIN 5480
	Shank size [mm]: 40.00
	Shank type: VDI
	Tool adaption: ER 32 A - u-tec
	Gear ratio [i]: 1:1
	Torque max [Nm]: 50
	Rotation max [1/min]: 6000
	Rotating direction: opposite
	Coolant: EXT
	Center distance [mm]: 100
8 030 46 317	Radial drilling and milling head ER 32 AX UT
	Weight [kg]: 7.280
	Version: right
	Tool drive: DIN 5480
	Shank size [mm]: 40.00
	Shank type: VDI
	Tool adaption: ER 32 A - u-tec
	Gear ratio [i]: 1:1
	Torque max [Nm]: 50
	Rotation max [1/min]: 6000
	Rotating direction: opposite
	Coolant: EXT
	Center distance [mm]: 120
8 030 47 018	Radial drilling and milling head HT 5 IC
	Version: left
	Tool drive: DIN 5480
	Shank size [mm]: 40.00
	Shank type: VDI
	Tool adaption: HT 5
	Gear ratio [i]: 1:1
	Torque max [Nm]: 50
	Rotation max [1/min]: 6000
	Rotating direction: opposite
	Coolant: IC/Ext
	Pressure max [bar]: 25
	Please note: Special version
	Center distance [mm]: 130

Part-#	Name
--------	------

8 030 47 029 Radial drilling and milling head HT 5

Version: left
 Tool drive: DIN 5480
 Shank size [mm]: 40.00
 Shank type: VDI
 Tool adaption: HT 5
 Gear ratio [i]: 1:1
 Torque max [Nm]: 50
 Rotation max [1/min]: 6000
 Rotating direction: opposite
 Coolant: EXT
 Please note: stronger bearing
 Center distance [mm]: 120

8 030 47 059 Radial drilling and milling head HT 5 IC



Weight [kg]: 8.030
 Version: left
 Tool drive: DIN 5480
 Shank size [mm]: 40.00
 Shank type: VDI
 Tool adaption: HT 5
 Gear ratio [i]: 1:1
 Torque max [Nm]: 50
 Rotation max [1/min]: 4000
 Rotating direction: opposite
 Coolant: IC/Ext
 Pressure max [bar]: 140
 Center distance [mm]: 120

8 030 47 067 Radial drilling and milling head HT 5

Weight [kg]: 5.560
 Version: left
 Tool drive: DIN 5480
 Shank size [mm]: 40.00
 Shank type: VDI
 Tool adaption: HT 5
 Gear ratio [i]: 1:1
 Torque max [Nm]: 50
 Rotation max [1/min]: 6000
 Rotating direction: opposite
 Coolant: EXT
 Center distance [mm]: 100

8 030 47 078 Radial drilling and milling head Weldon 25

Weight [kg]: 7.640
 Version: left
 Tool drive: DIN 5480
 Shank size [mm]: 40.00
 Shank type: VDI
 Tool adaption: Weldon (DIN 1835 b) 25
 Gear ratio [i]: 1:1
 Torque max [Nm]: 50
 Rotation max [1/min]: 6000
 Rotating direction: opposite
 Coolant: EXT
 Please note: stronger bearing
 Center distance [mm]: 100

Part-#	Name	
8 030 47 142	Radial drilling and milling head HT 5 IC	
	Weight [kg]:	8.290
	Version:	right
	Tool drive:	DIN 5480
	Shank size [mm]:	40.00
	Shank type:	VDI
	Tool adaption:	HT 5
	Gear ratio [i]:	1:2
	Torque max [Nm]:	16
	Rotation max [1/min]:	12000
	Rotating direction:	opposite
	Coolant:	IC/Ext
	Pressure max [bar]:	140
	Please note:	stronger bearing
	Center distance [mm]:	100
8 030 47 153	Radial drilling and milling head HT 5 IC	
	Weight [kg]:	8.610
	Version:	right
	Tool drive:	DIN 5480
	Shank size [mm]:	40.00
	Shank type:	VDI
	Tool adaption:	HT 5
	Gear ratio [i]:	1:1
	Torque max [Nm]:	50
	Rotation max [1/min]:	6000
	Rotating direction:	opposite
	Coolant:	IC/Ext
	Pressure max [bar]:	140
	Please note:	stronger bearing
	Center distance [mm]:	120
8 030 48 004	Radial drilling and milling head HT 6 IC	
	Version:	left
	Tool drive:	DIN 5480
	Shank size [mm]:	40.00
	Shank type:	VDI
	Tool adaption:	HT 6
	Gear ratio [i]:	2:1
	Torque max [Nm]:	63
	Rotation max [1/min]:	4000
	Rotating direction:	opposite
	Coolant:	IC/Ext
	Pressure max [bar]:	25
	Please note:	stronger bearing
	Center distance [mm]:	120
8 030 48 005	Radial drilling and milling head HT 6 IC	
	Version:	left
	Tool drive:	DIN 5480
	Shank size [mm]:	40.00
	Shank type:	VDI
	Tool adaption:	HT 6
	Gear ratio [i]:	1:2
	Torque max [Nm]:	16
	Rotation max [1/min]:	8000
	Rotating direction:	opposite
	Coolant:	IC/Ext

Part-#	Name	
	Please note:	stronger bearing
	Center distance [mm]:	120
8 030 48 006	Radial drilling and milling head HT 6 IC	
	Weight [kg]:	7.900
	Version:	left
	Tool drive:	DIN 5480
	Shank size [mm]:	40.00
	Shank type:	VDI
	Tool adaption:	HT 6
	Gear ratio [i]:	1:1
	Torque max [Nm]:	50
	Rotation max [1/min]:	6000
	Rotating direction:	opposite
	Coolant:	IC/Ext
	Pressure max [bar]:	140
	Please note:	stronger bearing
	Center distance [mm]:	100
8 030 48 012	Radial drilling and milling head HT 6	
	Weight [kg]:	8.220
	Version:	left
	Tool drive:	DIN 5480
	Shank size [mm]:	40.00
	Shank type:	VDI
	Tool adaption:	HT 6
	Gear ratio [i]:	1:1
	Torque max [Nm]:	50
	Rotation max [1/min]:	4000
	Rotating direction:	opposite
	Coolant:	EXT
	Please note:	stronger bearing
	Center distance [mm]:	120
8 030 48 017	Radial drilling and milling head HT 6 IC	
	Version:	Special; left
	Tool drive:	DIN 5480
	Shank size [mm]:	40.00
	Shank type:	VDI
	Tool adaption:	HT 6
	Gear ratio [i]:	1:1
	Torque max [Nm]:	50
	Rotation max [1/min]:	6000
	Rotating direction:	opposite
	Coolant:	IC/Ext
	Pressure max [bar]:	25
	Please note:	stronger bearing
	Center distance [mm]:	120
8 031 44 025	Radial milling head universal arbor 16	
	Version:	left
	Tool drive:	DIN 5480
	Shank size [mm]:	40.00
	Shank type:	VDI
	Tool adaption:	Universal arbor 16
	Gear ratio [i]:	1:1
	Torque max [Nm]:	50
	Rotation max [1/min]:	6000

Part-#	Name	
	Rotating direction:	opposite
	Coolant:	EXT
	Center distance [mm]:	100
8 031 45 019	Radial polygon head arbor 22	
	Weight [kg]:	7.330
	Version:	left
	Tool drive:	DIN 5480
	Shank size [mm]:	40.00
	Shank type:	VDI
	Tool adaption:	Polygon arbor 22
	Gear ratio [i]:	1:1
	Torque max [Nm]:	50
	Rotation max [1/min]:	6000
	Rotating direction:	opposite
	Coolant:	EXT
	Please note:	stronger bearing
	Center distance [mm]:	100
8 031 46 009	Radial milling head universal arbor 27	
	Version:	left
	Tool drive:	DIN 5480
	Shank size [mm]:	40.00
	Shank type:	VDI
	Tool adaption:	Universal arbor 27
	Gear ratio [i]:	2:1
	Torque max [Nm]:	63
	Rotation max [1/min]:	3000
	Rotating direction:	opposite
	Coolant:	EXT
	Please note:	Combi bearing
	Center distance [mm]:	100
8 033 47 013	Radial drilling and milling head HT 5 IC	
	Weight [kg]:	8.480
	Notation:	offset
	Version:	right
	Tool drive:	DIN 5480
	Shank size [mm]:	40.00
	Shank type:	VDI
	Tool adaption:	HT 5
	Gear ratio [i]:	1:1
	Torque max [Nm]:	50
	Rotation max [1/min]:	6000
	Rotating direction:	same
	Coolant:	IC/Ext
	Pressure max [bar]:	140
	Center distance [mm]:	100
8 033 47 023	Radial drilling and milling head HT 5	
	Weight [kg]:	8.960
	Notation:	offset
	Version:	left
	Tool drive:	DIN 5480
	Shank size [mm]:	40.00
	Shank type:	VDI
	Tool adaption:	HT 5
	Gear ratio [i]:	1:1

Part-#	Name	
	Torque max [Nm]:	50
	Rotation max [1/min]:	6000
	Rotating direction:	same
	Coolant:	EXT
	Center distance [mm]:	120
8 033 47 030	Radial drilling and milling head HT 5 IC	
	Weight [kg]:	9.540
	Notation:	offset
	Version:	left
	Tool drive:	DIN 5480
	Shank size [mm]:	40.00
	Shank type:	VDI
	Tool adaption:	HT 5
	Gear ratio [i]:	1:1
	Torque max [Nm]:	50
	Rotation max [1/min]:	6000
	Rotating direction:	same
	Coolant:	IC/Ext
	Pressure max [bar]:	140
	Center distance [mm]:	120
8 033 48 003	Radial drilling and milling head HT 6 IC	
	Weight [kg]:	8.940
	Notation:	offset
	Version:	right
	Tool drive:	DIN 5480
	Shank size [mm]:	40.00
	Shank type:	VDI
	Tool adaption:	HT 6
	Gear ratio [i]:	1:1
	Torque max [Nm]:	50
	Rotation max [1/min]:	6000
	Rotating direction:	same
	Coolant:	IC/Ext
	Pressure max [bar]:	140
	Please note:	stronger bearing
	Center distance [mm]:	100
8 033 48 004	Radial drilling and milling head HT 6 IC	
	Weight [kg]:	10.290
	Notation:	offset
	Version:	left
	Tool drive:	DIN 5480
	Shank size [mm]:	40.00
	Shank type:	VDI
	Tool adaption:	HT 6
	Gear ratio [i]:	1:1
	Torque max [Nm]:	50
	Rotation max [1/min]:	6000
	Rotating direction:	same
	Coolant:	IC/Ext
	Pressure max [bar]:	140
	Please note:	stronger bearing
	Center distance [mm]:	120

Part-#	Name	
8 033 48 005	Radial drilling and milling head HT 6	
	Notation:	offset
	Version:	left
	Tool drive:	DIN 5480
	Shank size [mm]:	40.00
	Shank type:	VDI
	Tool adaption:	HT 6
	Gear ratio [i]:	1:1
	Torque max [Nm]:	50
	Rotation max [1/min]:	6000
	Rotating direction:	same
	Coolant:	EXT
	Please note:	stronger bearing
	Center distance [mm]:	120
8 036 45 008	Radial drilling and milling head ER 25	
	Weight [kg]:	7.480
	Version:	doubletoothed
	Tool drive:	DIN 5480
	Shank size [mm]:	40.00
	Shank type:	VDI
	Tool adaption:	ER 25
	Gear ratio [i]:	1:1
	Torque max [Nm]:	50
	Rotation max [1/min]:	6000
	Rotating direction:	opposite
	Coolant:	EXT
	Center distance [mm]:	120
8 036 46 010	Radial drilling and milling head ER 32 AX UT	
	Weight [kg]:	6.490
	Version:	doubletoothed
	Tool drive:	DIN 5480
	Shank size [mm]:	40.00
	Shank type:	VDI
	Tool adaption:	ER 32 A - u-tec
	Gear ratio [i]:	1:1
	Torque max [Nm]:	50
	Rotation max [1/min]:	6000
	Rotating direction:	opposite
	Coolant:	EXT
	Center distance [mm]:	100
8 036 46 011	Radial drilling and milling head ER 32 AX UT IC	
	Weight [kg]:	7.870
	Version:	doubletoothed
	Tool drive:	DIN 5480
	Shank size [mm]:	40.00
	Shank type:	VDI
	Tool adaption:	ER 32 A - u-tec
	Gear ratio [i]:	1:1
	Torque max [Nm]:	50
	Rotation max [1/min]:	6000
	Rotating direction:	opposite
	Coolant:	IC/Ext
	Pressure max [bar]:	140
	Center distance [mm]:	120

Part-#	Name
8 036 46 012	Radial drilling and milling head ER 32 AX UT IC
	Weight [kg]: 6.920
	Version: doubletoothed
	Tool drive: DIN 5480
	Shank size [mm]: 40.00
	Shank type: VDI
	Tool adaption: ER 32 A - u-tec
	Gear ratio [i]: 1:1
	Torque max [Nm]: 50
	Rotation max [1/min]: 6000
	Rotating direction: opposite
	Coolant: IC/Ext
	Pressure max [bar]: 140
	Center distance [mm]: 100
8 036 46 014	Radial drilling and milling head ER 32 AX UT
	Weight [kg]: 7.270
	Version: doubletoothed
	Tool drive: DIN 5480
	Shank size [mm]: 40.00
	Shank type: VDI
	Tool adaption: ER 32 A - u-tec
	Gear ratio [i]: 1:1
	Torque max [Nm]: 50
	Rotation max [1/min]: 6000
	Rotating direction: opposite
	Coolant: EXT
	Center distance [mm]: 120
8 039 45 031	Radial drilling and milling head ER 25 AX UT
	Weight [kg]: 8.770
	Version: double spindle
	Tool drive: DIN 5480
	Shank size [mm]: 40.00
	Shank type: VDI
	Tool adaption: ER 25 A - u-tec
	Gear ratio [i]: 1:1
	Torque max [Nm]: 50
	Rotation max [1/min]: 6000
	Rotating direction: same/opposite
	Coolant: EXT
	Please note: stronger bearing
	Center distance [mm]: 120
8 039 45 048	Radial drilling and milling head ER 25 AX UT
	Weight [kg]: 7.940
	Version: double spindle
	Tool drive: DIN 5480
	Shank size [mm]: 40.00
	Shank type: VDI
	Tool adaption: ER 25 A - u-tec
	Gear ratio [i]: 1:1
	Torque max [Nm]: 50
	Rotation max [1/min]: 6000
	Rotating direction: same/opposite
	Coolant: EXT
	Please note: stronger bearing
	Center distance [mm]: 100

Part-#	Name	
8 039 46 016	Radial drilling and milling head ER 32	
	Version:	double spindle
	Tool drive:	DIN 5480
	Shank size [mm]:	40.00
	Shank type:	VDI
	Tool adaption:	ER 32
	Gear ratio [i]:	1:1
	Torque max [Nm]:	50
	Rotation max [1/min]:	6000
	Rotating direction:	same/opposite
	Coolant:	EXT
	Please note:	stronger bearing
	Center distance [mm]:	120
8 039 46 056	Radial drilling and milling head ER 32 AX UT	
	Version:	double spindle
	Tool drive:	DIN 5480
	Shank size [mm]:	40.00
	Shank type:	VDI
	Tool adaption:	ER 32 A - u-tec
	Gear ratio [i]:	1:1
	Torque max [Nm]:	50
	Rotation max [1/min]:	6000
	Rotating direction:	same/opposite
	Coolant:	EXT
	Please note:	stronger bearing
	Center distance [mm]:	120
8 039 46 058	Radial drilling and milling head ER 32 AX UT	
	Weight [kg]:	8.640
	Version:	double spindle; doubletoothed
	Tool drive:	DIN 5480
	Shank size [mm]:	40.00
	Shank type:	VDI
	Tool adaption:	ER 32 A - u-tec
	Gear ratio [i]:	1:1
	Torque max [Nm]:	50
	Rotation max [1/min]:	6000
	Rotating direction:	same/opposite
	Coolant:	EXT
	Please note:	stronger bearing
	Center distance [mm]:	120
8 039 47 004	Radial drilling and milling head HT 5	
	Weight [kg]:	9.120
	Version:	double spindle
	Tool drive:	DIN 5480
	Shank size [mm]:	40.00
	Shank type:	VDI
	Tool adaption:	HT 5
	Gear ratio [i]:	1:1
	Torque max [Nm]:	50
	Rotation max [1/min]:	6000
	Rotating direction:	same/opposite
	Coolant:	EXT
	Please note:	stronger bearing
	Center distance [mm]:	120

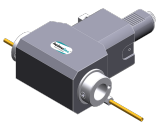

Part-#	Name
8 040 44 066	Universal head ± 90° adjustable ER 16 AX UT
	Version: right
	Tool drive: DIN 5480
	Shank size [mm]: 40.00
	Shank type: VDI
	Tool adaption: ER 16 A - u-tec
	Gear ratio [i]: 1:1
	Torque max [Nm]: 25
	Rotation max [1/min]: 6000
	Rotating direction: opposite
	Coolant: EXT
	Center distance [mm]: 87
8 040 44 067	Universal head ± 90° adjustable ER 16 AX UT
	Weight [kg]: 4.890
	Version: left
	Tool drive: DIN 5480
	Shank size [mm]: 40.00
	Shank type: VDI
	Tool adaption: ER 16 A - u-tec
	Gear ratio [i]: 1:1
	Torque max [Nm]: 25
	Rotation max [1/min]: 6000
	Rotating direction: opposite
	Coolant: EXT
	Center distance [mm]: 87
8 040 44 070	Universal head ± 90° adjustable ER 16 AX UT IC
	Version: right
	Tool drive: DIN 5480
	Shank size [mm]: 40.00
	Shank type: VDI
	Tool adaption: ER 16 A - u-tec
	Gear ratio [i]: 1:1
	Torque max [Nm]: 25
	Rotation max [1/min]: 6000
	Rotating direction: opposite
	Coolant: IC/Ext
	Pressure max [bar]: 140
	Center distance [mm]: 87
8 040 44 074	Universal head ± 90° adjustable ER 16 AX UT
	Version: left
	Tool drive: DIN 5480
	Shank size [mm]: 40.00
	Shank type: VDI
	Tool adaption: ER 16 A - u-tec
	Gear ratio [i]: 1:2
	Torque max [Nm]: 12
	Rotation max [1/min]: 12000
	Rotating direction: opposite
	Coolant: EXT
	Center distance [mm]: 87

Part-#	Name
8 040 44 078	Universal head ± 90° adjustable ER 16 AX UT IC
	Weight [kg]: 4.980
	Version: left
	Tool drive: DIN 5480
	Shank size [mm]: 40.00
	Shank type: VDI
	Tool adaption: ER 16 A - u-tec
	Gear ratio [i]: 1:2
	Torque max [Nm]: 12
	Rotation max [1/min]: 12000
	Rotating direction: opposite
	Coolant: IC/Ext
	Pressure max [bar]: 140
	Center distance [mm]: 87
8 040 45 067	Universal head ± 90° adjustable ER 25 AX UT
	Weight [kg]: 6.250
	Version: right
	Tool drive: DIN 5480
	Shank size [mm]: 40.00
	Shank type: VDI
	Tool adaption: ER 25 A - u-tec
	Gear ratio [i]: 1:1
	Torque max [Nm]: 25
	Rotation max [1/min]: 6000
	Rotating direction: opposite
	Coolant: EXT
	Please note: Note swivel range! strong bearing
	Center distance [mm]: 120
8 040 45 073	Universal head ± 90° adjustable ER 25 AX UT IC
	Version: left
	Tool drive: DIN 5480
	Shank size [mm]: 40.00
	Shank type: VDI
	Tool adaption: ER 25 A - u-tec
	Gear ratio [i]: 1:1
	Torque max [Nm]: 25
	Rotation max [1/min]: 6000
	Rotating direction: opposite
	Coolant: IC/Ext
	Pressure max [bar]: 140
	Please note: stronger bearing
	Center distance [mm]: 87
8 040 45 093	Universal head ± 90° adjustable ER 25 AX UT
	Weight [kg]: 5.160
	Version: right
	Tool drive: DIN 5480
	Shank size [mm]: 40.00
	Shank type: VDI
	Tool adaption: ER 25 A - u-tec
	Gear ratio [i]: 1:1
	Torque max [Nm]: 25
	Rotation max [1/min]: 6000
	Rotating direction: opposite
	Coolant: EXT
	Please note: stronger bearing

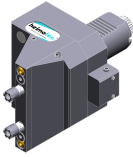
Part-#	Name	
	Center distance [mm]:	87
8 040 45 095	Universal head ± 90° adjustable ER 25 AX UT IC	
	Weight [kg]:	5.160
	Version:	right
	Tool drive:	DIN 5480
	Shank size [mm]:	40.00
	Shank type:	VDI
	Tool adaption:	ER 25 A - u-tec
	Gear ratio [i]:	1:1
	Torque max [Nm]:	25
	Rotation max [1/min]:	6000
	Rotating direction:	opposite
	Coolant:	IC/Ext
	Pressure max [bar]:	140
	Please note:	stronger bearing
	Center distance [mm]:	87
8 040 45 103	Universal head ± 90° adjustable ER 25 AX UT IC	
	Weight [kg]:	5.170
	Version:	left; at 65° position can be pinned
	Tool drive:	DIN 5480
	Shank size [mm]:	40.00
	Shank type:	VDI
	Tool adaption:	ER 25 A - u-tec
	Gear ratio [i]:	1:1
	Torque max [Nm]:	25
	Rotation max [1/min]:	6000
	Rotating direction:	opposite
	Coolant:	IC/Ext
	Pressure max [bar]:	140
	Please note:	stronger bearing
	Center distance [mm]:	87
8 040 45 139	Universal head ± 90° adjustable ER 25	
	Weight [kg]:	5.230
	Version:	left
	Tool drive:	DIN 5480
	Shank size [mm]:	40.00
	Shank type:	VDI
	Tool adaption:	ER 25
	Gear ratio [i]:	1:1
	Torque max [Nm]:	25
	Rotation max [1/min]:	6000
	Rotating direction:	opposite
	Coolant:	EXT
	Please note:	stronger bearing
	Center distance [mm]:	87
8 050 42 004	Multispindle drilling head ER 8	
	Weight [kg]:	4.780
	Notation:	offset
	Version:	2-spindles
	Tool drive:	DIN 5480
	Shank size [mm]:	40.00
	Shank type:	VDI
	Tool adaption:	ER 8

Part-#	Name	
	Gear ratio [i]:	1:1
	Torque max [Nm]:	5/Sp.
	Rotation max [1/min]:	6000
	Rotating direction:	opposite
	Coolant:	EXT
	Please note:	Check applicability!
	Offset [mm]:	26,076
8 200 40 000	Plug Z2-40 K	
	Weight [kg]:	0.140
	Shank size [mm]:	40.00
	Shank type:	VDI
8 200 40 001	Plug Z2-40 S	
	Weight [kg]:	1.360
	Shank size [mm]:	40.00
	Shank type:	VDI
8 206 42 000	Adapter for VDI 30	
	Weight [kg]:	3.530
	Version:	doubletoothed
	Shank size [mm]:	40.00
	Shank type:	VDI
	Tool adaption:	DIN 69880 - 30
	Coolant:	EXT
	Please note:	Special
8 208 49 001	Test mandrel VDI 40x40x200	
	Weight [kg]:	3.020
	Shank size [mm]:	40.00
	Shank type:	VDI
8 208 49 003	Test mandrel VDI 40x40x300	
	Weight [kg]:	4.020
	Shank size [mm]:	40.00
	Shank type:	VDI
8 209 44 006	Adapter for VDI 40	
	Notation:	offset
	Version:	right
	Shank size [mm]:	40.00
	Shank type:	VDI
	Tool adaption:	DIN 69880 - 40
	Coolant:	EXT
	Center distance [mm]:	120
8 209 44 007	Adapter for VDI 40	
	Notation:	offset
	Version:	left
	Shank size [mm]:	40.00
	Shank type:	VDI
	Tool adaption:	DIN 69880 - 40
	Coolant:	EXT
	Center distance [mm]:	120

Part-#	Name	
8 209 44 013	Adapter for VDI 40	
	Version:	right
	Shank size [mm]:	40.00
	Shank type:	VDI
	Tool adaption:	DIN 69880 - 40
	Coolant:	EXT
	Center distance [mm]:	120
8 209 44 014	Adapter for VDI 40	
	Version:	left
	Shank size [mm]:	40.00
	Shank type:	VDI
	Tool adaption:	DIN 69880 - 40
	Coolant:	EXT
	Center distance [mm]:	120
8 210 41 000	Tool holder F 40-MK 1	
	Weight [kg]:	1.600
	Shank size [mm]:	40.00
	Shank type:	VDI
	Tool adaption:	DIN 228 D - MK 1
	Coolant:	IC
8 210 42 001	Tool holder F 40-MK 2	
	Weight [kg]:	1.620
	Shank size [mm]:	40.00
	Shank type:	VDI
	Tool adaption:	DIN 228 D - MK 2
	Coolant:	IC
8 210 43 000	Tool holder E2-40x 8	
	Shank size [mm]:	40.00
	Shank type:	VDI
	Tool adaption:	Ø 8
	Coolant:	IC/Ext
8 210 43 002	Tool holder F 40-MK 3	
	Weight [kg]:	1.520
	Shank size [mm]:	40.00
	Shank type:	VDI
	Tool adaption:	DIN 228 D - MK 3
	Coolant:	IC
8 210 43 003	Short drill chuck VDI 40x 8	
	Weight [kg]:	1.700
	Shank size [mm]:	40.00
	Shank type:	VDI
	Coolant:	EXT
8 210 43 004	Short drill chuck VDI 40x 8 - IC	
	Weight [kg]:	1.730
	Shank size [mm]:	40.00
	Shank type:	VDI
	Coolant:	IC

Part-#	Name	
8 210 44 001	Tool holder E2-40x10	
	Weight [kg]:	2.320
	Shank size [mm]:	40.00
	Shank type:	VDI
	Tool adaption:	Ø 10
	Coolant:	IC/Ext
8 210 44 007	Tool holder F 40-MK 4	
	Weight [kg]:	2.460
	Shank size [mm]:	40.00
	Shank type:	VDI
	Tool adaption:	DIN 228 D - MK 4
	Coolant:	IC
8 210 44 008	Short drill chuck VDI 40x13	
	Weight [kg]:	2.280
	Shank size [mm]:	40.00
	Shank type:	VDI
	Coolant:	EXT
8 210 44 010	Tool holder E1-40x10	
	Shank size [mm]:	40.00
	Shank type:	VDI
	Tool adaption:	Ø 10
	Coolant:	IC
8 210 44 011	Tool holder E1-40x12	
	Shank size [mm]:	40.00
	Shank type:	VDI
	Tool adaption:	Ø 12
	Coolant:	IC
8 210 44 014	Short drill chuck VDI 40x13 - IC	
	Weight [kg]:	2.290
	Shank size [mm]:	40.00
	Shank type:	VDI
	Coolant:	IC
8 210 44 019	Tool holder E2-40x10 - special	
	Shank size [mm]:	40.00
	Shank type:	VDI
	Tool adaption:	Ø 10
	Coolant:	IC/Ext
	Please note:	Shaft with hole, locked with screw
8 210 44 020	Tool holder E2-40x12 - special	
	Shank size [mm]:	40.00
	Shank type:	VDI
	Tool adaption:	Ø 12
	Coolant:	IC/Ext
	Please note:	Shaft with hole, locked with screw
8 210 45 000	Tool holder E2-40x16	
	Shank size [mm]:	40.00
	Shank type:	VDI
	Tool adaption:	Ø 16
	Coolant:	IC/Ext

Part-#	Name	
	8 210 45 002 Tool holder E4-40xER 25	
	Weight [kg]:	1.570
	Shank size [mm]:	40.00
	Shank type:	VDI
	Tool adaption:	ER 25
	Coolant:	IC
	8 210 45 003 Tool holder E1-40x16	
	Shank size [mm]:	40.00
	Shank type:	VDI
	Tool adaption:	Ø 16
	Coolant:	IC
	8 210 45 006 Short drill chuck VDI 40x16	
	Weight [kg]:	2.460
	Shank size [mm]:	40.00
	Shank type:	VDI
	Coolant:	EXT
	8 210 45 009 Short drill chuck VDI 40x16 - IC	
	Weight [kg]:	2.320
	Shank size [mm]:	40.00
	Shank type:	VDI
	Coolant:	IC
	8 210 45 020 Tool holder ER 25 AX UT IC	
	Weight [kg]:	1.860
	Shank size [mm]:	40.00
	Shank type:	VDI
	Tool adaption:	ER 25 A - u-tec
	Coolant:	IC/Ext
	8 210 46 000 Tool holder E4-40xER 32	
	Weight [kg]:	1.640
	Shank size [mm]:	40.00
	Shank type:	VDI
	Tool adaption:	ER 32
	Coolant:	IC
	8 210 46 002 Tool holder E2-40x20	
	Shank size [mm]:	40.00
	Shank type:	VDI
	Tool adaption:	Ø 20
	Coolant:	IC/Ext
	8 210 46 004 Tool holder E1-40x20	
	Shank size [mm]:	40.00
	Shank type:	VDI
	Tool adaption:	Ø 20
	Coolant:	IC

Part-#	Name	
8 210 46 010	Tool holder E2-40x20 - special	
	Shank size [mm]:	40.00
	Shank type:	VDI
	Tool adaption:	Ø 20
	Coolant:	IC/Ext
	Please note:	Shaft with hole, locked with screw
8 210 47 001	Tool holder E2-40x25	
	Shank size [mm]:	40.00
	Shank type:	VDI
	Tool adaption:	Ø 25
	Coolant:	IC/Ext
8 210 47 004	Tool holder E4-40xER 40	
	Shank size [mm]:	40.00
	Shank type:	VDI
	Tool adaption:	ER 40
	Coolant:	IC
8 210 47 005	Tool holder E1-40x25	
	Weight [kg]:	1.840
	Shank size [mm]:	40.00
	Shank type:	VDI
	Tool adaption:	Ø 25
	Coolant:	IC
8 210 48 001	Tool holder E2-40x32	
	Shank size [mm]:	40.00
	Shank type:	VDI
	Tool adaption:	Ø 32
	Coolant:	IC/Ext
8 210 48 004	Tool holder E1-40x32	
	Weight [kg]:	1.830
	Shank size [mm]:	40.00
	Shank type:	VDI
	Tool adaption:	Ø 32
	Coolant:	IC
8 210 48 012	Tool holder E2-40x32 special	
	Version:	Special
	Shank size [mm]:	40.00
	Shank type:	VDI
	Tool adaption:	Ø 32
	Coolant:	IC/Ext
	Please note:	with end stop
8 210 49 000	Tool holder E2-40x40	
	Shank size [mm]:	40.00
	Shank type:	VDI
	Tool adaption:	Ø 40
	Coolant:	IC/Ext

Part-#	Name	
8 210 49 002	Tool holder E1-40x40	
	Shank size [mm]:	40.00
	Shank type:	VDI
	Tool adaption:	Ø 40
	Coolant:	IC
8 210 49 003	Tool holder E1-40x50	
	Shank size [mm]:	40.00
	Shank type:	VDI
	Tool adaption:	Ø 50
	Coolant:	IC
8 210 49 005	Tool holder E2-40x50	
	Weight [kg]:	3.000
	Shank size [mm]:	40.00
	Shank type:	VDI
	Tool adaption:	Ø 50
	Coolant:	IC/Ext
8 215 43 000	Tool holder C2-40x25	
	Employment for:	VDI 40
	Version:	left
	Shank size [mm]:	40.00
	Shank type:	VDI
	Tool adaption:	Sq. 25/20
	Coolant:	EXT
8 215 43 001	Tool holder C4-40x25	
	Employment for:	VDI 40
	Version:	left
	Shank type:	VDI
	Tool adaption:	Sq. 25/20
	Coolant:	EXT
8 215 43 003	Tool holder C2-40x25 special	
	Weight [kg]:	4.480
	Version:	left
	Shank size [mm]:	40.00
	Shank type:	VDI
	Tool adaption:	Sq. 25/20
	Coolant:	EXT
8 219 47 004	Boring bar holder ø 25	
	Weight [kg]:	2.820
	Version:	left; offset
	Shank size [mm]:	40.00
	Shank type:	VDI
	Tool adaption:	Ø 25
	Coolant:	IC/Ext
	Offset [mm]:	25

Part-#	Name		
8 219 48 006	Boring bar holder Ø 32 	Version:	left, offset
		Shank size [mm]:	40.00
		Shank type:	VDI
		Tool adaption:	Ø 32
		Coolant:	IC/Ext
		Offset [mm]:	30
8 231 47 006	Boring bar holder Ø 25	Version:	left
		Shank size [mm]:	40.00
		Shank type:	VDI
		Tool adaption:	Ø 25
		Coolant:	IC/Ext
		Please note:	demountable in right version
8 231 48 000	Tool holder HT 6	Center distance [mm]:	120
		Weight [kg]:	6.080
		Notation:	offset
		Version:	left
		Shank size [mm]:	40.00
		Shank type:	VDI
8 231 48 007	Boring bar holder Ø 32	Tool adaption:	HT 6
		Coolant:	IC/Ext
		Center distance [mm]:	100
		Version:	left
		Shank size [mm]:	40.00
		Shank type:	VDI
8 231 49 007	Boring bar holder Ø 40	Tool adaption:	Ø 32
		Coolant:	IC/Ext
		Please note:	demountable in right version
		Center distance [mm]:	120
		Weight [kg]:	6.510
		Version:	left
8 234 45 003	Combi facing holder sq. 25/20	Shank size [mm]:	40.00
		Shank type:	VDI
		Tool adaption:	Sq. 25/20
		Coolant:	EXT
		Weight [kg]:	6.160
		Shank size [mm]:	40.00

Part-#	Name	
8 234 45 004	Combi facing holder sq. 25/20	
	Weight [kg]:	9.780
	Shank size [mm]:	40.00
	Shank type:	VDI
	Tool adaption:	Sq. 25/20
	Coolant:	EXT
8 235 43 000	Tool holder B2-40x25x44	
	Employment for:	VDI 40
	Version:	left
	Shank size [mm]:	40.00
	Shank type:	VDI
	Tool adaption:	Sq. 25/20
	Coolant:	EXT
8 235 43 001	Tool holder B4-40x25x44	
	Employment for:	VDI 40
	Version:	left
	Shank size [mm]:	40.00
	Shank type:	VDI
	Tool adaption:	Sq. 25/20
	Coolant:	EXT
8 235 43 002	Tool holder B6-40x25x44	
	Employment for:	VDI 40
	Version:	left; long
	Shank size [mm]:	40.00
	Shank type:	VDI
	Tool adaption:	Sq. 25/20
	Coolant:	EXT
8 235 43 003	Tool holder B8-40x25x44	
	Weight [kg]:	3.360
	Version:	Left
	Shank size [mm]:	40.00
	Shank type:	VDI
	Tool adaption:	Sq. 25/20
	Coolant:	EXT
8 235 43 009	Tool holder B6-40x25x44 special	
	Weight [kg]:	2.960
	Employment for:	VDI 40
	Version:	Special; left
	Shank size [mm]:	40.00
	Shank type:	VDI
	Tool adaption:	Sq. 25/20
	Coolant:	EXT
	Please note:	Insert for system "Jetstream" from Seco
8 235 43 010	Tool holder B2-40x25x44 special	
	Weight [kg]:	2.260
	Employment for:	VDI 40
	Version:	Special; left
	Shank size [mm]:	40.00
	Shank type:	VDI
	Tool adaption:	Sq. 25/20
	Coolant:	EXT

Part-#	Name	
	Please note:	Insert for system "Jetstream" from Seco
8 239 45 005	Double collet chuck holder ER 25	
	Weight [kg]:	6.140
	Employment for:	Main- and sub spindle
	Shank size [mm]:	40.00
	Shank type:	VDI
	Tool adaption:	ER 25
	Coolant:	IC/Ext
	Center distance [mm]:	100
8 239 46 018	Double boring bar holder Ø 20	
	Shank size [mm]:	40.00
	Shank type:	VDI
	Tool adaption:	Ø 20
	Coolant:	IC/Ext
	Center distance [mm]:	120
8 239 46 019	Double boring bar holder Ø 20	
	Employment for:	Heavy duty cutting
	Shank size [mm]:	40.00
	Shank type:	VDI
	Tool adaption:	Ø 20
	Coolant:	IC/Ext
	Center distance [mm]:	120
8 239 47 009	Double boring bar holder Ø 25	
	Weight [kg]:	9.290
	Shank size [mm]:	40.00
	Shank type:	VDI
	Tool adaption:	Ø 25
	Coolant:	IC/Ext
	Center distance [mm]:	120
8 239 47 010	Double boring bar holder Ø 25	
	Employment for:	Heavy duty cutting
	Shank size [mm]:	40.00
	Shank type:	VDI
	Tool adaption:	Ø 25
	Coolant:	IC/Ext
	Center distance [mm]:	120
8 239 48 001	Double boring bar holder Ø 32	
	Weight [kg]:	9.070
	Shank size [mm]:	40.00
	Shank type:	VDI
	Tool adaption:	Ø 32
	Coolant:	IC/Ext
	Center distance [mm]:	120
8 239 49 006	Double boring bar holder Ø 40	
	Weight [kg]:	8.660
	Shank size [mm]:	40.00
	Shank type:	VDI
	Tool adaption:	Ø 40
	Coolant:	IC/Ext
	Center distance [mm]:	120

Part-#	Name	
8 239 49 008	Double boring bar holder Ø 40	
	Employment for:	Heavy duty cutting
	Shank size [mm]:	40.00
	Shank type:	VDI
	Tool adaption:	Ø 40
	Coolant:	IC/Ext
	Center distance [mm]:	120
8 262 49 005	Stock stop VDI 40 - Ø 60 OD turret	
	Weight [kg]:	6.320
	Notation:	offset
	Version:	left
	Shank size [mm]:	40.00
	Shank type:	VDI
	Rotation max [1/min]:	8000
	Coolant:	without
	Center distance [mm]:	120
8 262 49 006	Stock stop VDI 40 - Ø 60 OD turret	
	Weight [kg]:	6.320
	Notation:	offset
	Version:	right
	Shank size [mm]:	40.00
	Shank type:	VDI
	Rotation max [1/min]:	8000
	Coolant:	without
	Center distance [mm]:	120
8 274 43 000	Square multiple holder D1-40x25	
	Weight [kg]:	3.660
	Shank size [mm]:	40.00
	Shank type:	VDI
	Tool adaption:	Sq. 25/20
	Coolant:	EXT
8 274 43 001	Tool holder D2-40x25	
	Weight [kg]:	4.300
	Shank size [mm]:	40.00
	Shank type:	VDI
	Tool adaption:	Sq. 25/20
	Coolant:	EXT



heimatec.u-tec®

heimatec.com

Products / Tool change systems /
u-tec® Tool-changing system



versions see catalog



heimatec.easy-quick

heimatec.com

Products / Tool change systems /
easy-quick HT quick-changing system



versions see catalog



heimatec.Capto™

heimatec.com

Products / Tool change systems /
heimatec.Capto™ quick-changing system



versions see catalog

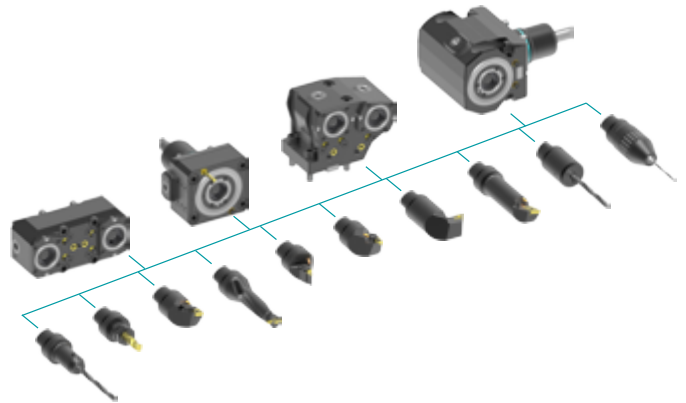

heimatec.accessories

heimatec.com

Products / Accessories



versions see catalog





● heimatec overseas branches

○ global representations of heimatec

heimatec[®]

heimatec GmbH
Präzisionswerkzeuge
Carl-Benz-Str. 4
77871 Renchen
Germany

T +49 7843 9466 0
www.heimatec.com
info@heimatec.com

Please find the contact details of our worldwide trading partners on our website:
<https://heimatec.com/business-partners>